

COMPONENT LIST

ITEM NO.	DESCRIPTION	MAT'L	COMPONENT NO.	QTY.
1	STRAND	SST	304-01-003	
2	STRAND EQUALIZER	SST	304-48-008	2
3	ROD	SST	304-53-011	1
4	LINK	BRZ	372-55-001	1
5	LUG	BRZ	372-56-008	2
6	TAG	MYLAR	309-77-0751	1

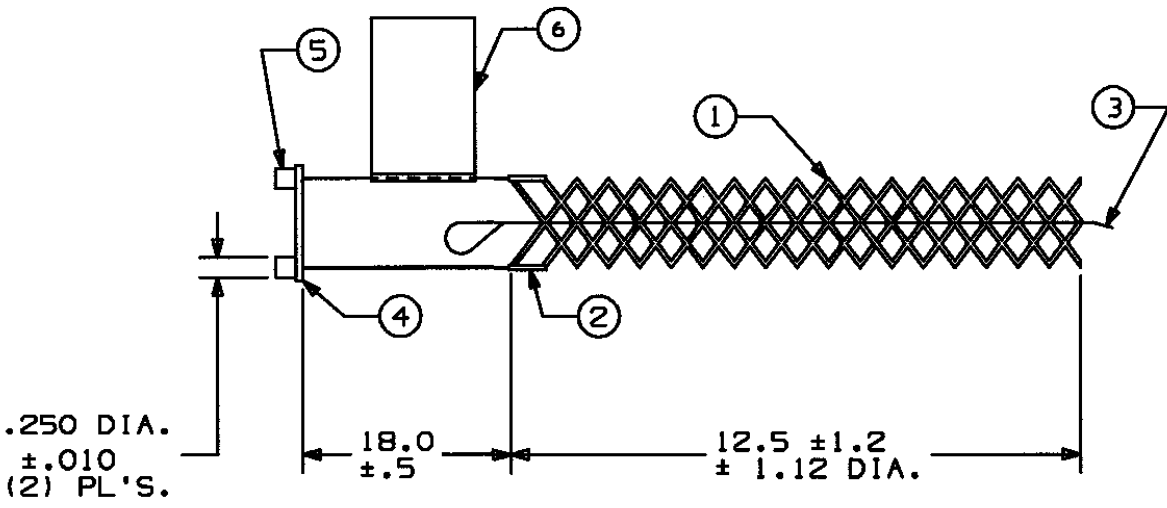

IN ACCEPTING OUR DRAWINGS OR BLUEPRINTS FOR QUOTATION OR OTHER PURPOSES, YOU AGREE NOT TO DISCLOSE TO OTHERS THE IDEAS, INFORMATION, OR DESIGNS THEREIN SHOWN, AND THAT YOU WILL MAKE NO USE OF OUR DRAWINGS OR BLUEPRINTS OR OF THE IDEAS, INFORMATION, OR DESIGNS THEREIN SHOWN WITHOUT OUR PERMISSION.

TITLE GRIP - SST - STANDARD SUPPORT
 SPLIT MESH, ROD CLOSING, SINGLE WEAVE
 UNIVERSAL BALE
 DIA. RA. 1.00-1.24
 DESCRIPTION: RRU 100-18-SS
 APP. BRK. STR. (LBS.) =2650

TOLERANCES UNLESS OTHERWISE SPECIFIED .X = ±.5 .XX = ±.05 .XXX = ±.015 ANGLE TOL. ± 2°	HUBBELL INCORPORATED KELLEMS DIVISION STONINGTON, CT
PROJECT NO.	DR. BY KJW APP. BY MLF
	TR. BY SCALE NONE
	CHK. BY DATE 3/19/93
DR. NO.	REV.
024-03-068	G
SHEET	OF