

COMPONENT LIST

ITEM NO.	DESCRIPTION	MAT'L	COMPONENT NO.	QTY.
1	GRIP, CORD	SST/AL	044-16-001	1
2	NUT	ALUM	311-48-026	1
3	BUSHING	NEOP	315-18-104	1
4	BODY	ALUM	371-48-088	1
5	CARTON	PAPER	309-20-027	1/5
6	INSTRUCTION	PAPER	309-20-059	1/5
7	LABEL	PAPER	309-75-002	2/5

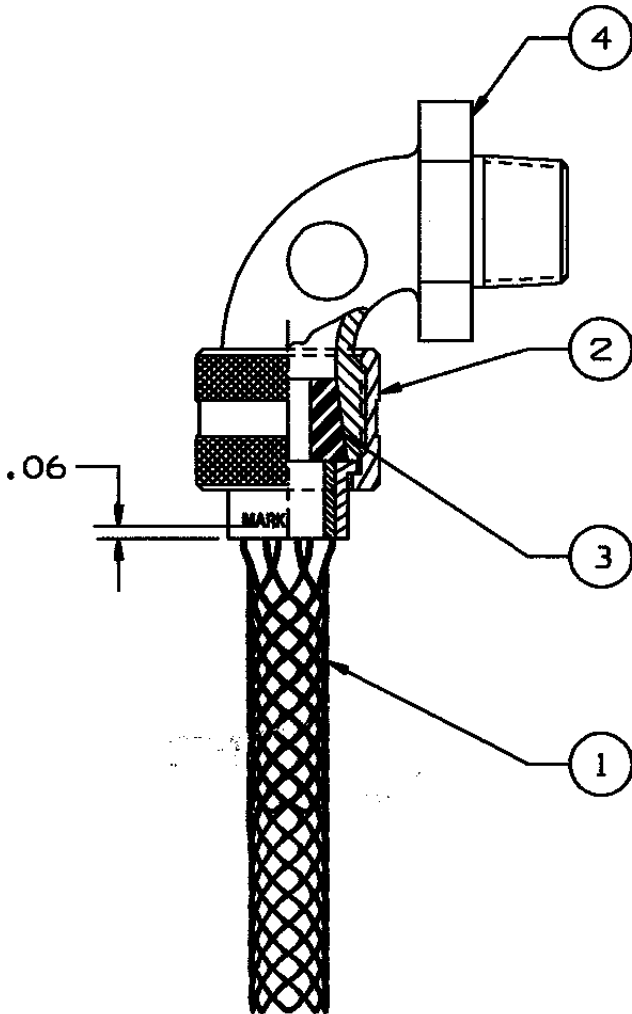

SUPRSEDES DRAWING
DATED 12-5-79

IN ACCEPTING OUR DRAWINGS OR BLUEPRINTS FOR QUOTATION OR OTHER PURPOSES, YOU AGREE NOT TO DISCLOSE TO OTHERS THE IDEAS, INFORMATION, OR DESIGNS THEREIN SHOWN, AND THAT YOU WILL MAKE NO USE OF OUR DRAWINGS OR BLUEPRINTS OR OF THE IDEAS, INFORMATION, OR DESIGNS THEREIN SHOWN WITHOUT OUR PERMISSION.

TITLE
DELUXE CORD GRIP
3/8" 90° MALE; 3/8NPT, F
DIA. RANGE .250-.312
CG 305-90

TOLERANCES UNLESS OTHERWISE SPECIFIED
.X = ±.5
.XX = ±.05
.XXX = ±.015
ANGLE TOL. ± 2°

HUBBELL INCORPORATED
KELLEMS DIVISION
STONINGTON, CT

PROJECT NO.

DR. BY GL	APP. BY
TR. BY JMN	SCALE N/A
CHK. BY	DATE 3/25/

DR. NO.

074-01-071

REV.

L

SHEET 1 OF 1