

M-10144 4

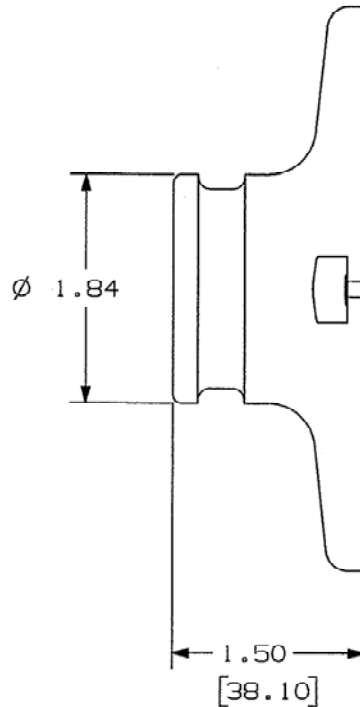
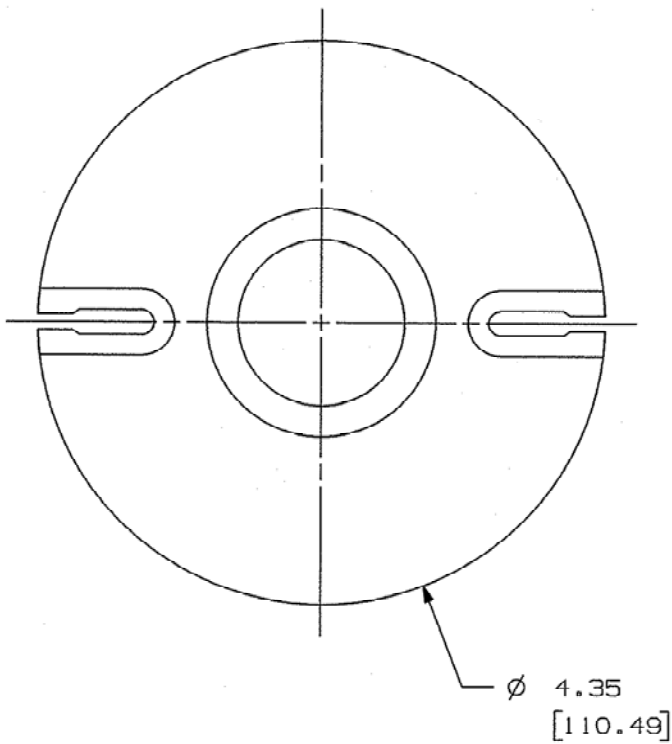

NOTES:

PRODUCT SPECIFICATIONS:

4 SCREW  
 660W-250V  
 INCLUDES (2) #8-32 MOUNTING SCREWS  
 cUL LISTED  
 DIMENSIONS : INCHES  
 MILIMETERS

CODE 74545

LIST OF PARTS

DESCRIPTION	MATERIAL	FINISH
LAMPHOLDER BASE	PORCELAIN	WHITE
SCREWS, MOUNTING	STEEL	

SYM	REVISIONS	APP	DATE
4	5/13/09 ADDED DIM. Ø 1.84 PER DCN 15759 MJM	TLS	5/13/09
3	PRODUCT SPECIFICATIONS, ADD DIM. INCH & MM. ADD DIM. Ø 4.35 & 1.50 DCN 15492 GPK	RDK	2/10/09
2	IN "PRODUCT SPECIFICATIONS", "660W -250V" WAS "660W-600V" AND "cUL LISTED" WAS "UL LISTED" PER DCN #14628. JMN	RDK	02/28/08
1	08/21/06 RELEASED TO PRODUCTION PER DCN# 13353	RDK	08/21/06

THE DESIGN AND DIMENSIONS OF THE  
 PRODUCT SHOWN ON THIS DRAWING ARE  
 SUBJECT TO CHANGE WITHOUT NOTICE

TITLE  
 OUTLET BOX LAMPHOLDER  
 MEDIUM BASE, PORCELAIN  
 KEYLESS 4 SCREW

TOLERANCES UNLESS OTHERWISE SPECIFIED	HUBBELL WIRING SYSTEMS BRIDGEPORT, CT	
FRACTIONS ± 1/64	DR. BY AMZ	APP. BY RDK
DECIMALS ± .005	TR. BY	SCALE NONE
ANGLES ± 2°	CHK'D BY RDK	DATE 05/09/06

DIMENSION SHEET FOR CAT. NO. FL8804  
 REPAIRABLE  NON-REPAIRABLE  B M-10144 4