

M-10464

1

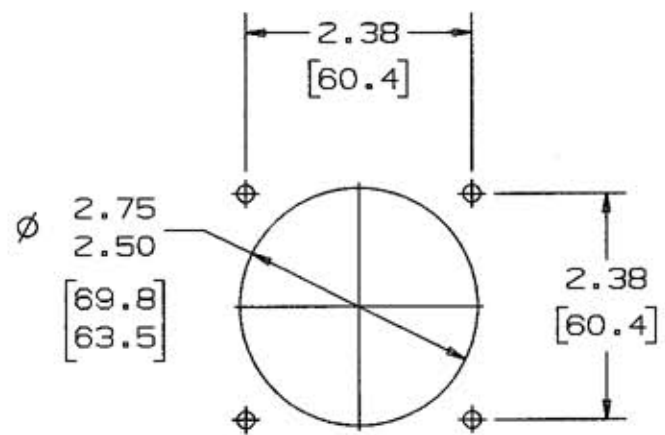
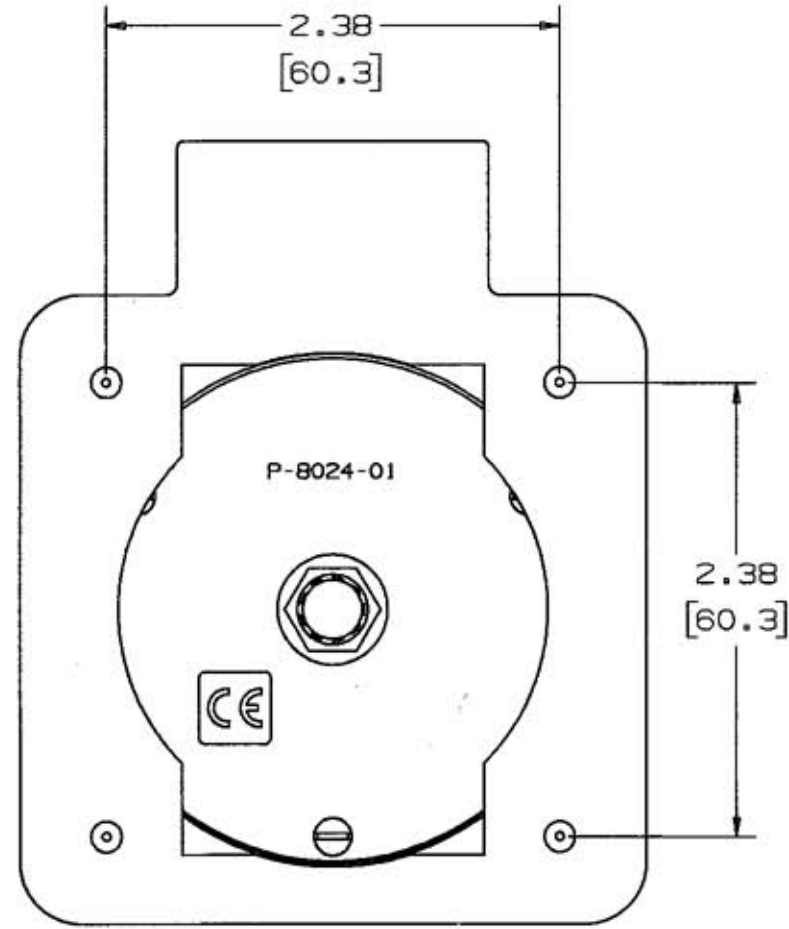
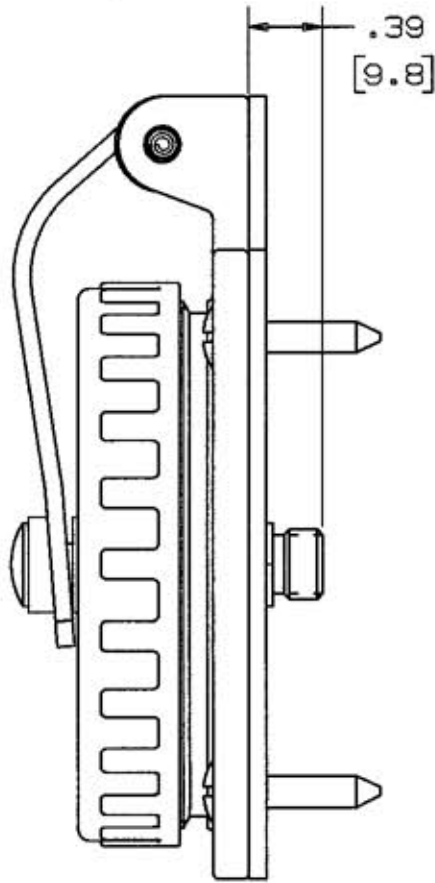
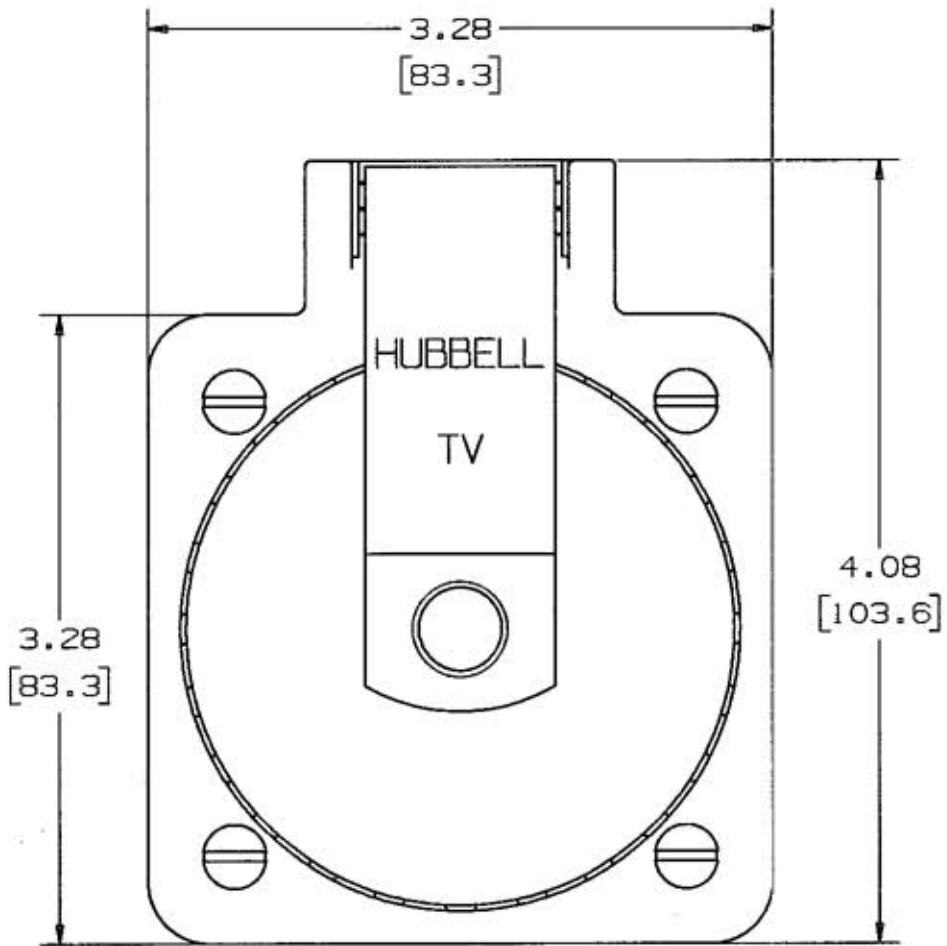

CUTOUT OPENING

LIST OF PARTS

DESCRIPTION	MATERIAL	FINISH
COVER	ST. STEEL	
THREADED BODY	ST. STEEL	
INTERIOR	NYLON	
INTERIOR SCREWS	BRASS	CHROME PLATED
MOUNTING SCREWS	ST. STEEL	
GASKETS	NEOPRENE	
TYPE "F" FEMALE CONN.	BRASS	NICKEL PLATED

DIMENSION SHEET FOR CAT. NO. HBLTVSS

REPAIRABLE NON-REPAIRABLE

1	"X" REMOVED, LAST "X" REVISION WAS "X-0" PER DCN #13823 RCM	WUH WUH	3/15/07
SYM	REVISIONS	APP	DATE

B

THE DESIGN AND DIMENSIONS OF THE PRODUCT SHOWN ON THIS DRAWING ARE SUBJECT TO CHANGE WITHOUT NOTICE

TITLE

STAINLESS STEEL
SHORE TV INLET

M-10464

TOLERANCES UNLESS OTHERWISE SPECIFIED FRACTIONS ±1/64 DECIMALS ±.005 ANGLES ±2°	WIRING DEVICE-KELLEMS HUBBELL INCORPORATED BRIDGEPORT, CT	
	DR. BY RCM	APP. BY WUH
	TR. BY	SCALE .5:1
	CHK'D BY WUH	DATE 3/15/07

1