

M11288 1

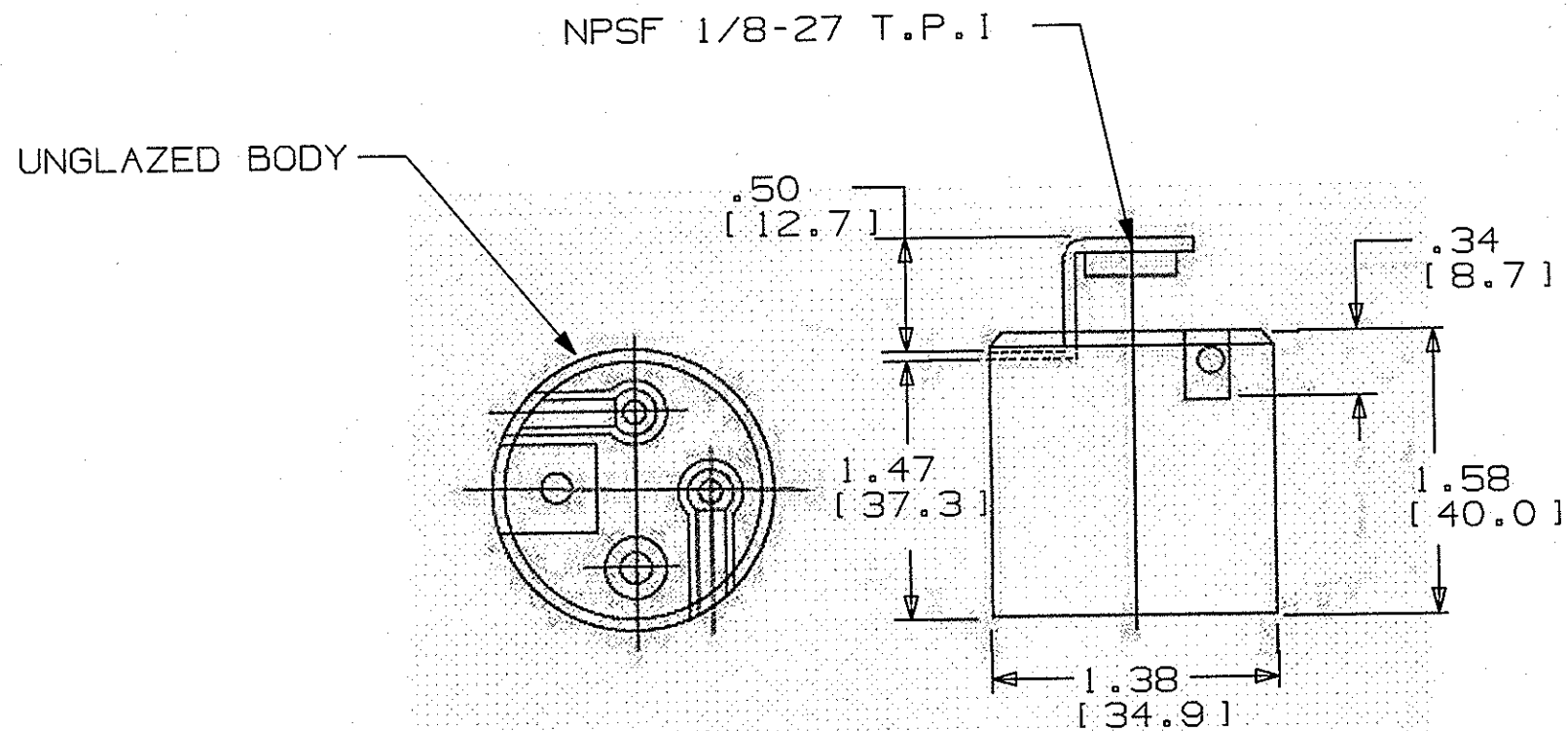

NOTES:

1. DIMENSIONS ARE INCHES [mm].
2. SCREW SHELL COMPLIES TO MEDIUM BASE LAMPHOLDER ANSI-C81.10 STD2-11-1 AND IEC E26.
3. STANDARD LEADS ARE 18 AWG, EXL 125° C, 12" LONG, STRIPPED 1/2".
c UL US LISTED; CSA CERTIFIED.
4. RATED 660W MAX, 250V MAX.
5. PACKAGING: PRODUCT PLACED IN BOX.

LIST OF PARTS

DESCRIPTION	MATERIAL	FINISH
LAMPHOLDER	PORCELAIN	WHITE
SCREW SHELL	ALUM	

DIMENSION SHEET FOR CAT. NO.

RL160

REPAIRABLE

NON-REPAIRABLE

B

M11288

1

1	12/01/09 RELEASE TO PRODUCTION PER DCN 16198	CAC	
SYM	REVISIONS	APP	DATE

THE DESIGN AND DIMENSIONS OF THE PRODUCT SHOWN ON THIS DRAWING ARE SUBJECT TO CHANGE WITHOUT NOTICE

TITLE INCANDESCENT SOCKET
MED BASE 1/2" HKY
12" LEADS

TOLERANCES UNLESS OTHERWISE SPECIFIED FRACTIONS ± 1/64 DECIMALS ± .005 ANGLES ± 2'	WIRING DEVICE-KELLEMS HUBBELL INCORPORATED BRIDGEPORT, CT	
	DR. BY DLI	APP. BY
	TR. BY	SCALE NONE
	CHK'D BY	DATE 04/01/09