

M-11742

1

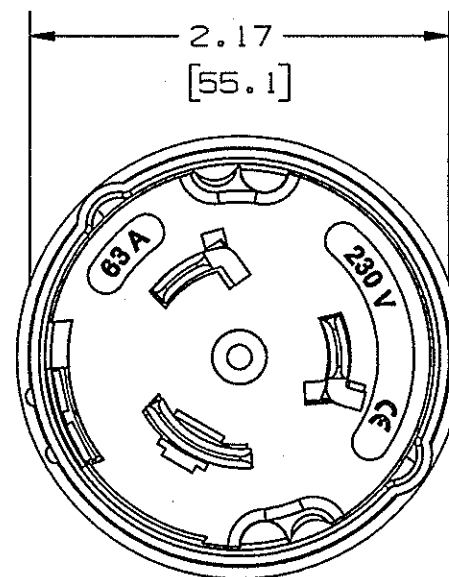
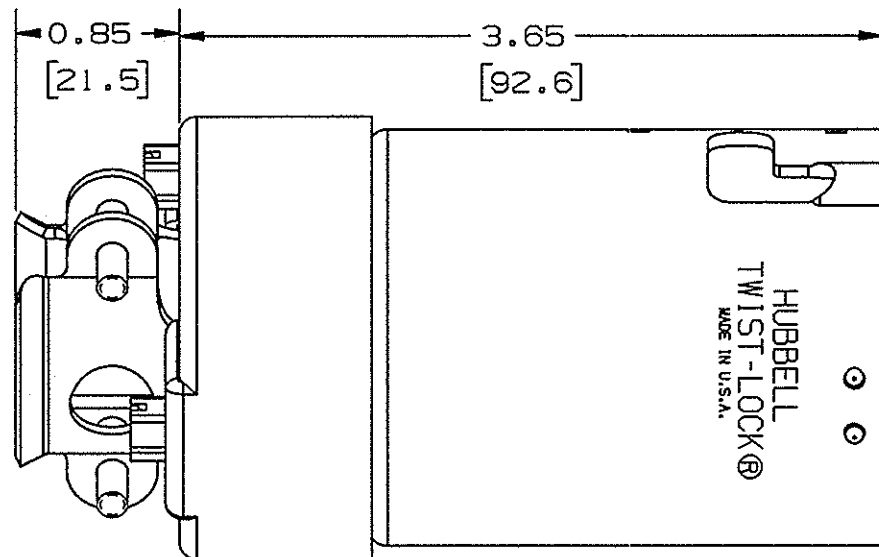
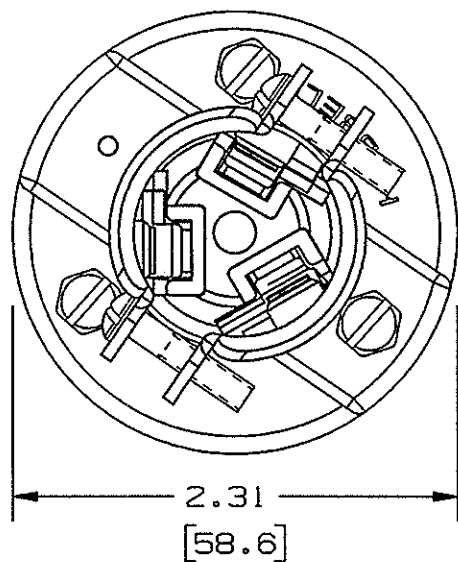
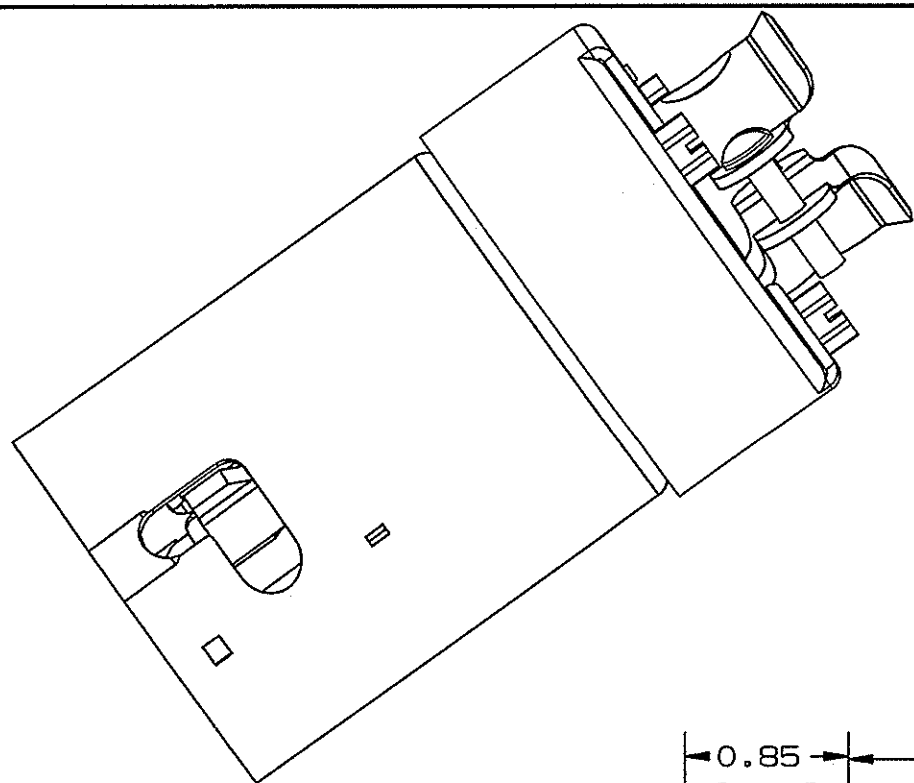

LIST OF PARTS		
DESCRIPTION	MATERIAL	FINISH
BLADES	BRASS	NICKEL PLATE
BLADE HOLDER	PHENOLIC	
BASE	PHENOLIC	
TERMINAL (L)	COPPER	BLACK DYE
TERMINAL (G)	COPPER	GREEN FINISH
TERMINAL (N)	COPPER	NICKEL PLATE
COVERS	BRASS	NICKEL PLATE
CORD RETAINER	ELASTOMER	
CORD CLAMPS	BRASS	NICKEL PLATE
RIVET	BRASS	NICKEL PLATE
PRESSURE SCREWS	ST. STEEL	
#8-32 RD. HD. SCRS	BRASS	NICKEL PLATE
#10-32 HEX. HD. SCRS	BRASS	NICKEL PLATE

DIMENSION SHEET FOR CAT. NO. SEE TABLE

REPAIRABLE  NON-REPAIRABLE

B

M-11742

1

1	RELEASED PER DCN #16965. DLI	DLI	10/19/10
SYM	REVISIONS	APP	DATE

THE DESIGN AND DIMENSIONS OF THE PRODUCT SHOWN ON THIS DRAWING ARE SUBJECT TO CHANGE WITHOUT NOTICE

TITLE  
63A TWIST LOCK MARINE PLUG

TOLERANCES UNLESS OTHERWISE SPECIFIED FRACTIONS ± 1/64 DECIMALS ± .005 ANGLES ± 2°	WIRING DEVICE-KELLEMS HUBBELL INCORPORATED BRIDGEPORT, CT	
	DR. BY DLI	APP. BY
	TR. BY	SCALE NONE
	CHK'D BY	DATE 9/15/10

CAT. No.	CONFIGURATION	WIRING TERMINAL VIEW	RATING
HBL363CRP			63A 230V. 2-POLE 3-WIRE

NOTES:

- ONLY #6/3 AWG COPPER WIRE CAN BE USED.  
CORD RANGE: Ø .97 TO 1.1 INCH, TYPE STOW OR STOW-A.
- ALL DIMENSIONS ARE INCHES.  
[ mm ]