

M11760 1

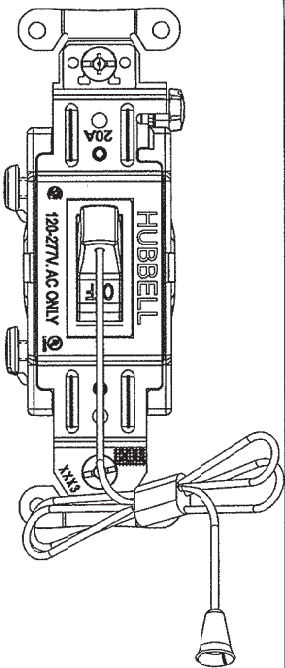

INSTALLED VIEW

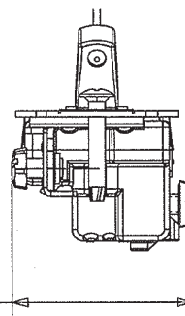
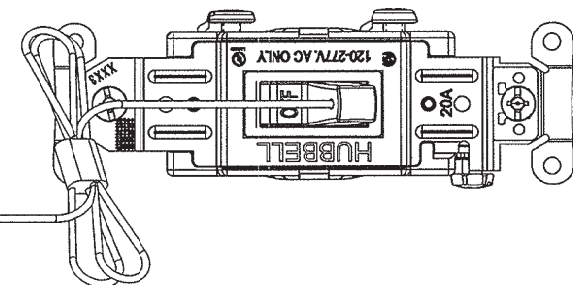
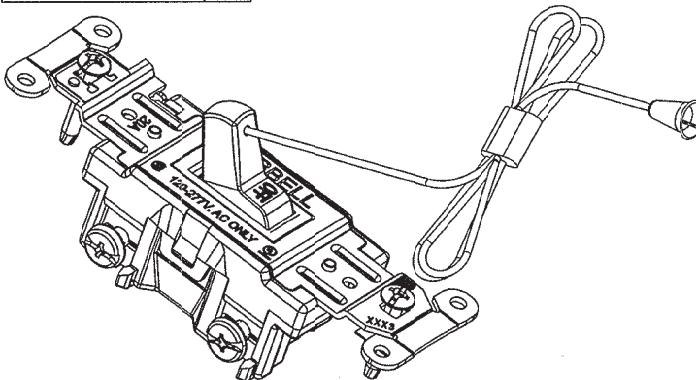

1.45 [36.75]

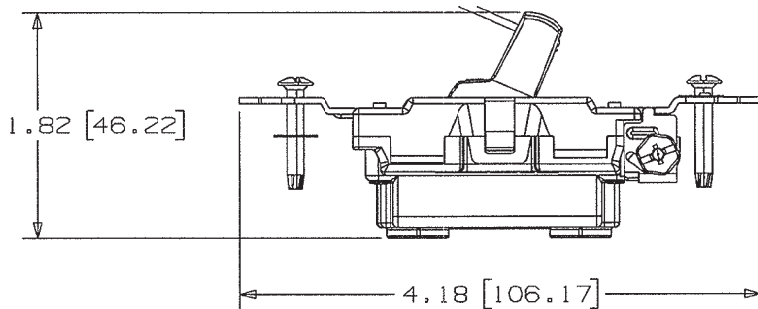

1.82 [46.22]

4.18 [106.17]

NOTES: (UNLESS OTHERWISE SPECIFIED)
 1. DIMENSIONS ARE IN INCHES [mm].
 2. CORD LENGTH 3 FEET.

CATALOG No.	RATING/TYPE	TOGGLE COLOR
HBL12213HCS	20A 120-277VAC S.P.	GRAY
HBL12211HCS	20A 120-277VAC S.P.	IVORY
HBL1221WHCS	20A 120-277VAC S.P.	WHITE

LIST OF PARTS

DESCRIPTION	MATERIAL	FINISH
TOGGLE	THERMOPLASTIC	
TOP HOUSING	THERMOPLASTIC	
BOTTOM HOUSING	THERMOPLASTIC	
RUBBER BUMPER	ELASTOMER	
RIVET	STEEL	ZINC PLATED
GROUND GLIP	301 ST. STEEL	
MOUNTING SCREW	STEEL	ZINC PLATED
WASHER	THERMOPLASTIC	
STRAP	STEEL	ZINC PLATED
CLAMPS	STEEL	NICKEL PLATED
ACTUATOR SPRING	SPRING WIRE	
TERMINALS	BRASS	BRIGHT DIP
GROUND SCREW	STEEL	DYE GREEN
TERMINAL SCREW	BRASS	BRIGHT DIP
PULL CORD	NYLON	
PENDANT	BRASS	NICKEL PLATE

DIMENSION SHEET FOR CAT. NO.

SEE TABLE

REPAIRABLE

NON-REPAIRABLE

B

M11760

1

1	NEW RELEASE PER DCN #17254	D.L.I. 11/16/10
SYM	REVISIONS	APP DATE

THE DESIGN AND DIMENSIONS OF THE PRODUCT SHOWN ON THIS DRAWING ARE SUBJECT TO CHANGE WITHOUT NOTICE

TITLE
 HOSPITAL CALL SWITCH, SP

TOLERANCES UNLESS OTHERWISE SPECIFIED	WIRING DEVICE-KELLEMS HUBBELL INCORPORATED BRIDGEPORT, CT	
FRACTIONS ± 1/64	DR. EY D.L.I.	APP. BY
DECIMALS ± .005	TR. EY	SCALE 1 : 1
ANGLES ± 2°	CHK'G BY	DATE 10/25/10