

M-12082 1

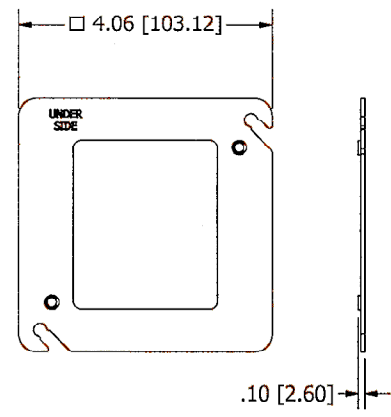

COVER ASSY

METAL COVER

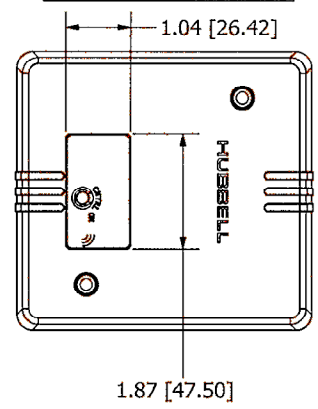
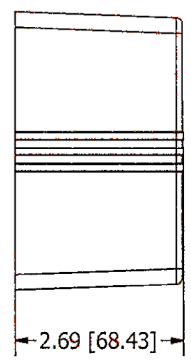
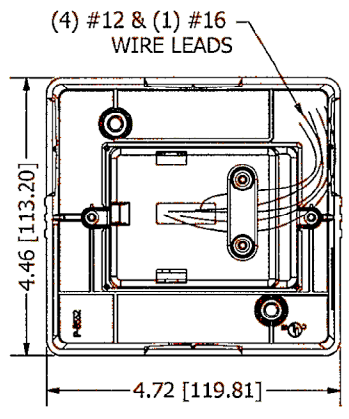
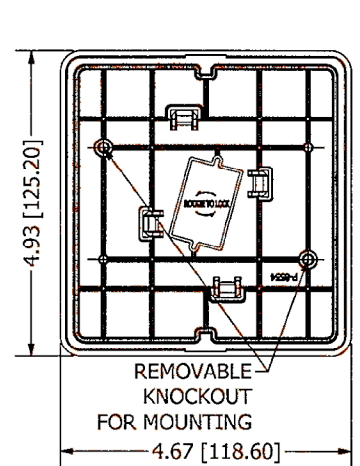

BOTTOM

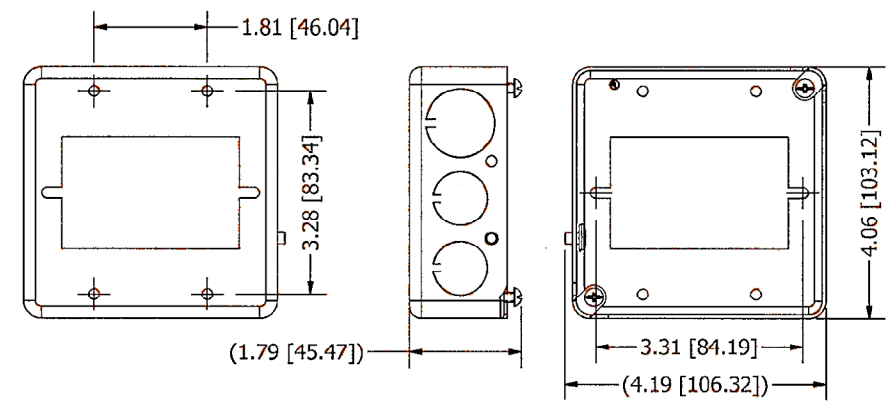

METAL EXTENSION BOX

NOTES: (UNLESS OTHERWISE SPECIFIED)

- 1. ALL DIMENSIONS ARE IN INCHES [mm].
- 2. WIRE LEADS ARE 6" LONG STRANDED WIRE WITH 1/2" STRIPPED END.
- 3. RATING: 20A, 100-277 V AC.

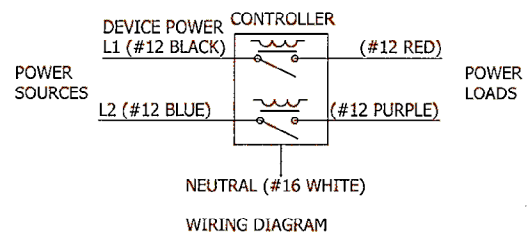

LIST OF PARTS

DESCRIPTION	MATERIAL	FINISH
FACE	THERMOPLASTIC	
BOTTOM	THERMOPLASTIC	
METAL COVER	STEEL	Zn PLATE
METAL EXTENSION BOX	STEEL	Zn PLATE
PCB	EPOXY RESIN	
SCREWS	STEEL	Zn PLATE
WIRE CLAMP	THERMOPLASTIC	
WASHER	STEEL	Zn PLATE
PCB HOUSING	THERMOPLASTIC	

1	NEW RELEASE PER DCN #19877	DL	06/19/13
SYM	DESCRIPTION	APPRO	DATE

THE DESIGN AND DIMENSIONS OF THE PRODUCT SHOWN ON THIS DRAWING ARE SUBJECT TO CHANGE WITHOUT NOTICE

TITLE DUAL RELAY WIRELESS PLUG LOAD CONTROLLER KIT

TOLERANCES UNLESS OTHERWISE SPECIFIED		WIRING DEVICE-KELLEMS HUBBELL INCORPORATED SHELTON, CT	
FRACTIONS	±1/64	DR. BY	DL
DECIMALS	±.005	TR. BY	SCALE 1:2
ANGLES	±.2°	CHK'D BY	DATE 8/22/2011