

M-12493

1

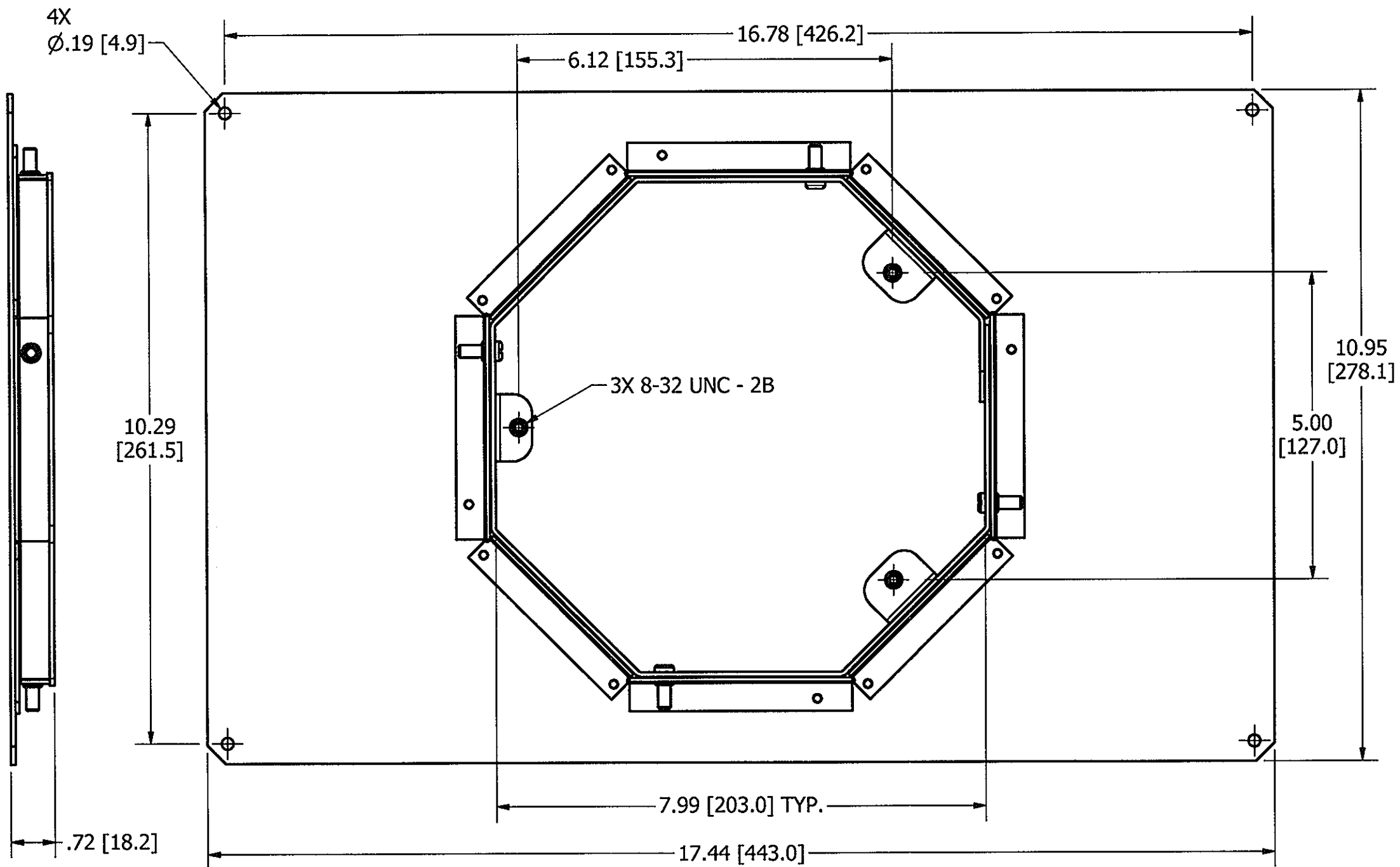

TEMPORARY CONCRETE COVER NOT SHOWN

NOTES:

1. ALL DIMENSIONS ARE IN INCHES AND [MILLIMETERS].
2. PRODUCT IS cULus LISTED. COMPLIES WITH UL 514A.
3. USE WITH RECESSED 6-GANG CONCRETE FLOOR BOXES (CFB6Gxx), SOLD SEPARATELY.
4. USE WITH SYSTEM 1 RECESSED 8 INCH COVERS (S1R8CVRxx), SOLD SEPARATELY.
5. MOUNTING HARDWARE INCLUDED.

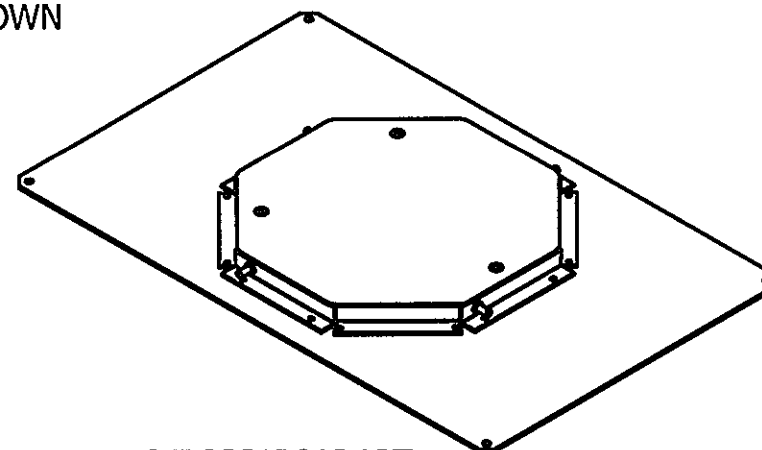

CFB6GS1R8ADAPT

LIST OF PARTS

DESCRIPTION	MATERIAL	FINISH
ADAPTER PLATE	14 GA. STEEL	ZINC
ANGLE BRACKETS	16 GA. STEEL	ZINC
COLLAR	16 GA. STEEL	ZINC
HARDWARE	STEEL	ZINC

1	INITIAL RELEASE PER DCN19233	SBW	11/15/13
SYM	DESCRIPTION	APP	DATE

THE DESIGN AND DIMENSIONS OF THE PRODUCT SHOWN ON THIS DRAWING ARE SUBJECT TO CHANGE WITHOUT NOTICE

TITLE
**ADAPTER ASSEMBLY, SYSTEM ONE
 RECESSED 8 INCH COVER TO
 RECESSED 6-GANG CONC. FLOORBOX**

TOLERANCES UNLESS OTHERWISE SPECIFIED		WIRING DEVICE-KELLEMS HUBBELL INCORPORATED SHELTON, CT.	
.XX = ± .01	.XXX = ± .005	DR. BY SBW	APP. BY
ANGLES = ± 2°		TR. BY	SCALE 1/2
		CHK'D BY SM	DATE 9/23/2013

DIMENSION SHEET FOR CAT. NO. CFB6GS1R8ADAPT

REPAIRABLE NON-REPAIRABLE

B

M-12493

1