

M-13166

1

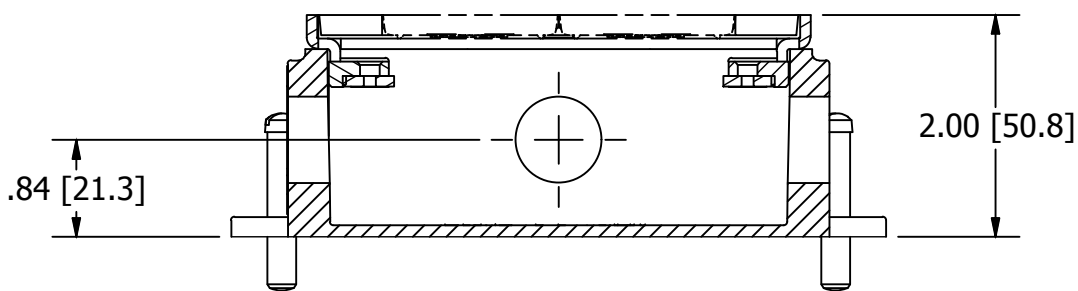
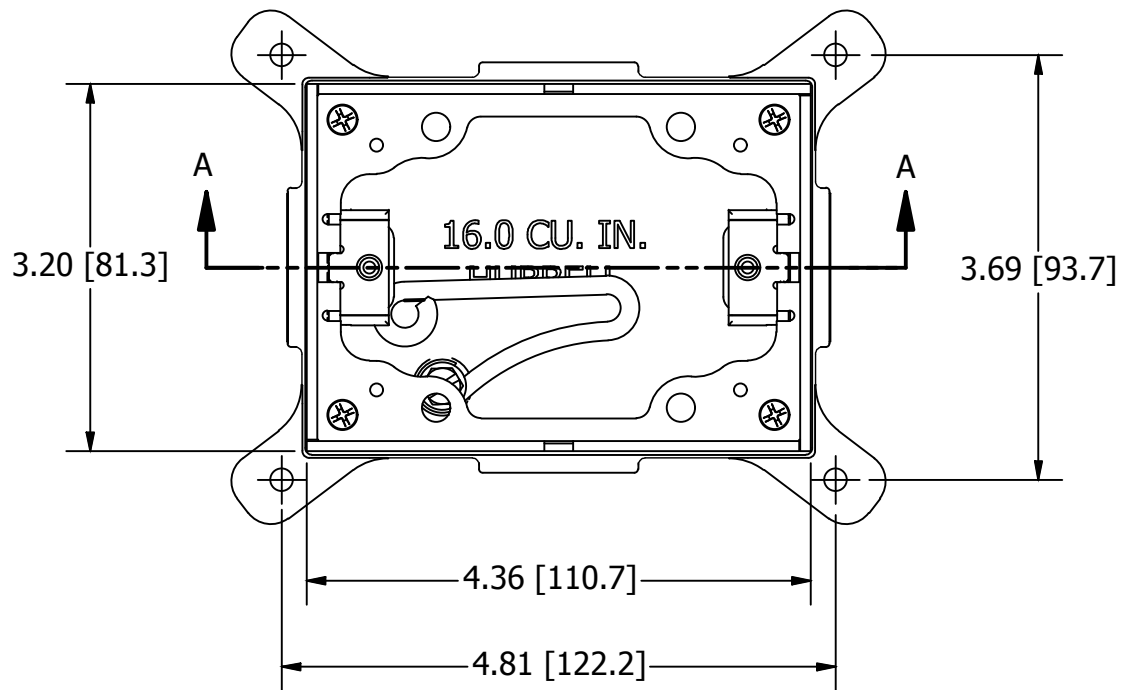
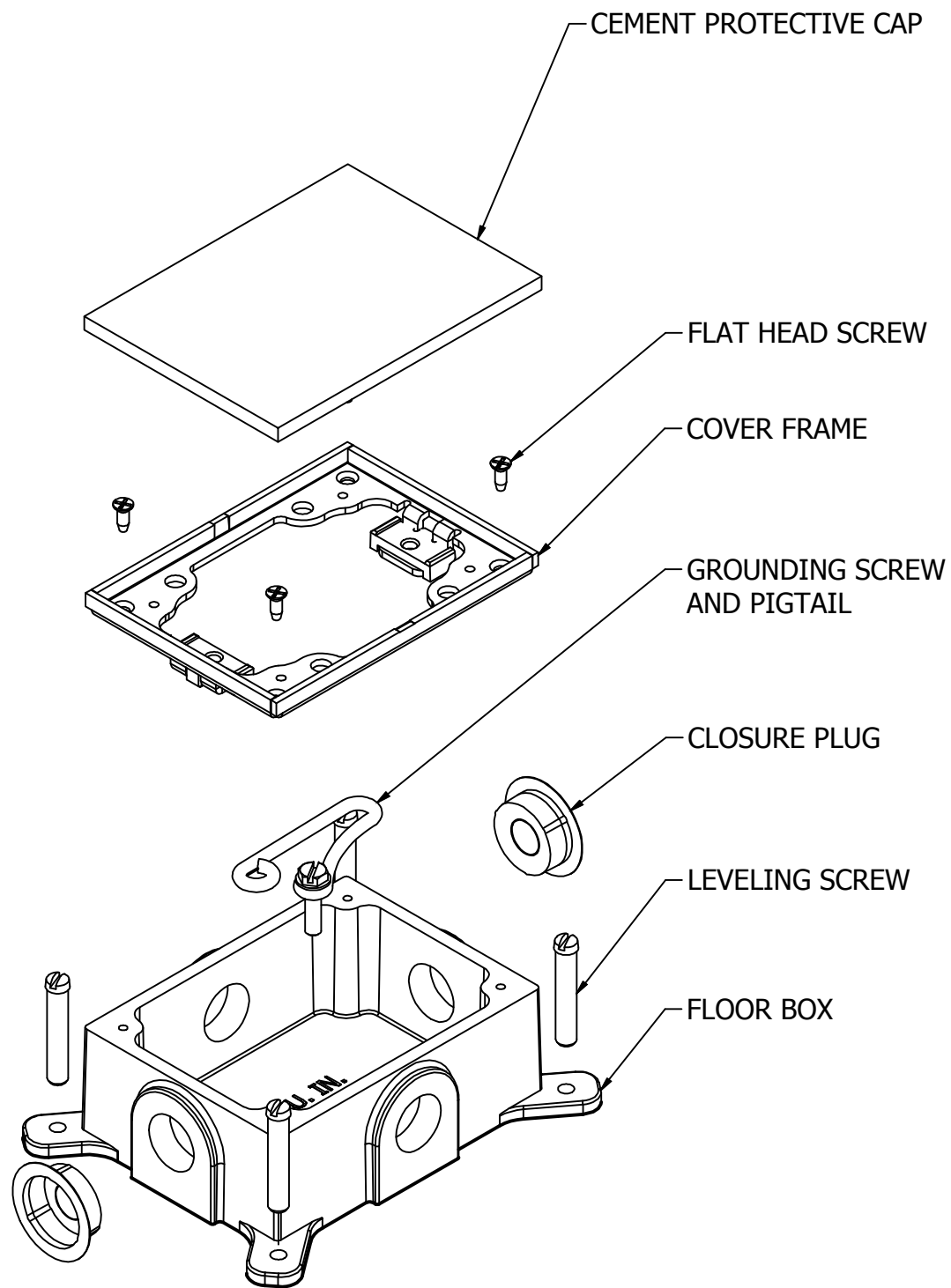

SECTION A-A
THROUGH FLOOR BOX

NOTES:

1. PRODUCT IS UL & CSA LISTED.COMPLIES WITH UL 514A, CSA C22.2 NO. 85-14.

LIST OF PARTS

DESCRIPTION	MATERIAL	FINISH
FLOOR BOX (1-GANG)	GRAY IRON	GRAY
CLOSURE PLUG	STEEL	TIN PLATE
SCREW FLAT HEAD	STEEL	ZINC PLATE
COVER FRAME	BRASS/AL	
SCREW,LEVELING	STEEL	ZINC PLATE
GROUNDING SCREW & PIGTAIL	COPPER	GREEN INSUL
PROTECTIVE CAP	STEEL	TIN PLATE

DIMENSION SHEET FOR CAT. NO. B2414, BA2414

1	INITIAL RELEASE. PER DCN 22067	DDL	04/18/16
REV	DESCRIPTION	APP	DATE

THE DESIGN AND DIMENSIONS OF THE PRODUCT SHOWN ON THIS DRAWING ARE SUBJECT TO CHANGE WITHOUT NOTICE. DIMENSIONS ARE IN INCHES [mm].

TITLE

CAST, RECTANGULAR, ONE GANG, 2.00" DEEP FAMILY



WIRING DEVICE-KELLEMS
HUBBELL INCORPORATED
SHELTON, CT

TOLERANCES UNLESS OTHERWISE SPECIFIED
.XX = ± .01
.XXX = ± .005
ANGLE TOL. ±2'

DR. BY
CHK. BY DDL

SCALE NONE
DATE 04/15/16

B

M-13166

1

M-13166

1

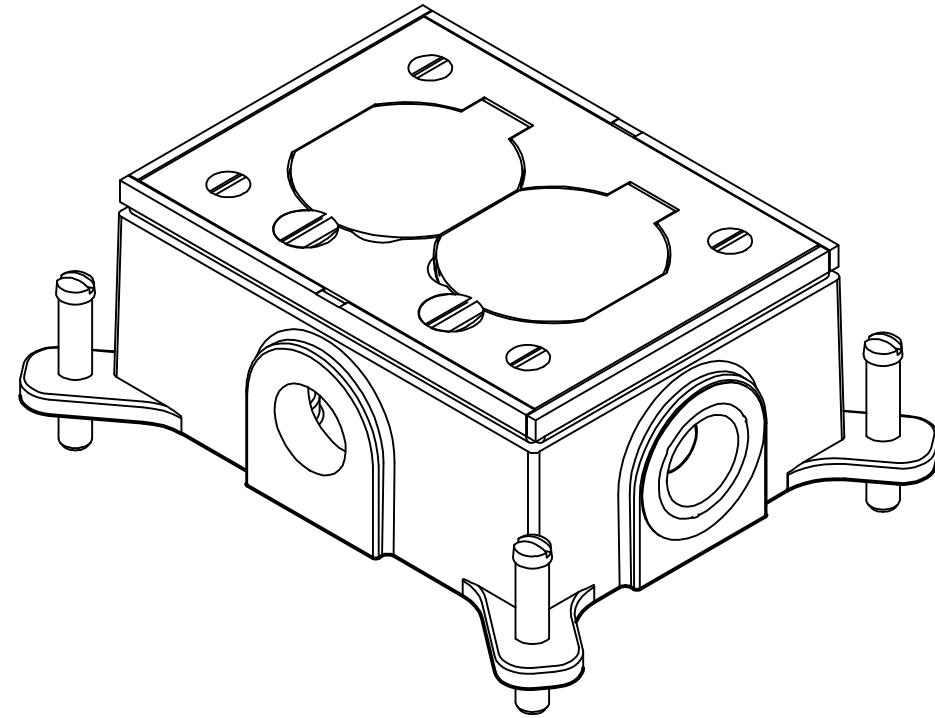

B2414
CAST STEEL FLOOR BOX

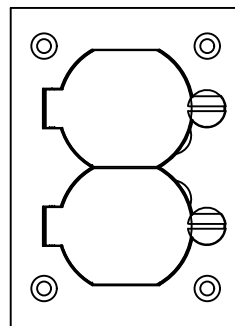

S3825
SA3825

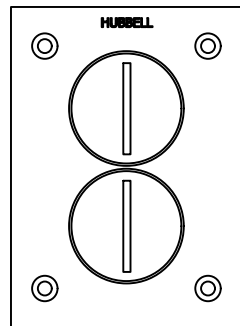

S3625
SA3625

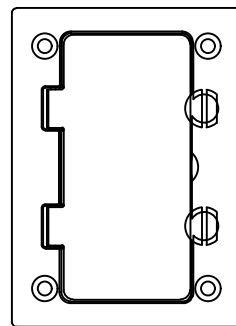

S3826
SA3826

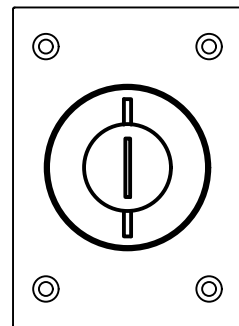

S2425
SA2425

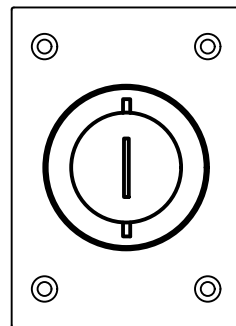

S2625
SA2625

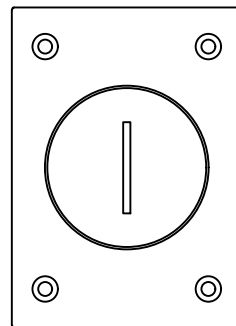

S2825
-

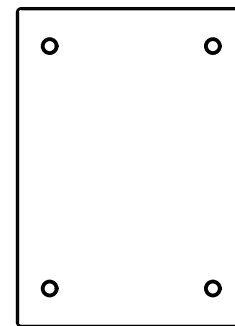

S3813
SA3813

SHOWN SINGLE SERVICE COVERS SOLD SEPARATELY

LIST OF PARTS

DESCRIPTION	MATERIAL	FINISH
SEE SHEET 1		

DIMENSION SHEET FOR CAT. NO.
B2414, BA2414

1	INITIAL RELEASE. PER DCN 22067	DDL	04/18/16
REV	DESCRIPTION	APP	DATE

THE DESIGN AND DIMENSIONS OF THE
PRODUCT SHOWN ON THIS DRAWING ARE
SUBJECT TO CHANGE WITHOUT NOTICE.
DIMENSIONS ARE IN INCHES [mm].

TITLE
CAST, RECTANGULAR, ONE GANG, 2.00"
DEEP FAMILY



WIRING DEVICE-KELLEMS
HUBBELL INCORPORATED
SHELTON, CT

TOLERANCES UNLESS OTHERWISE SPECIFIED .XX = ± .01 .XXX = ± .005 ANGLE TOL. ±2'	DR. BY	SCALE	NONE
	CHK. BY	DATE	04/15/16

SHEET 2 OF 2