

M-13392 1

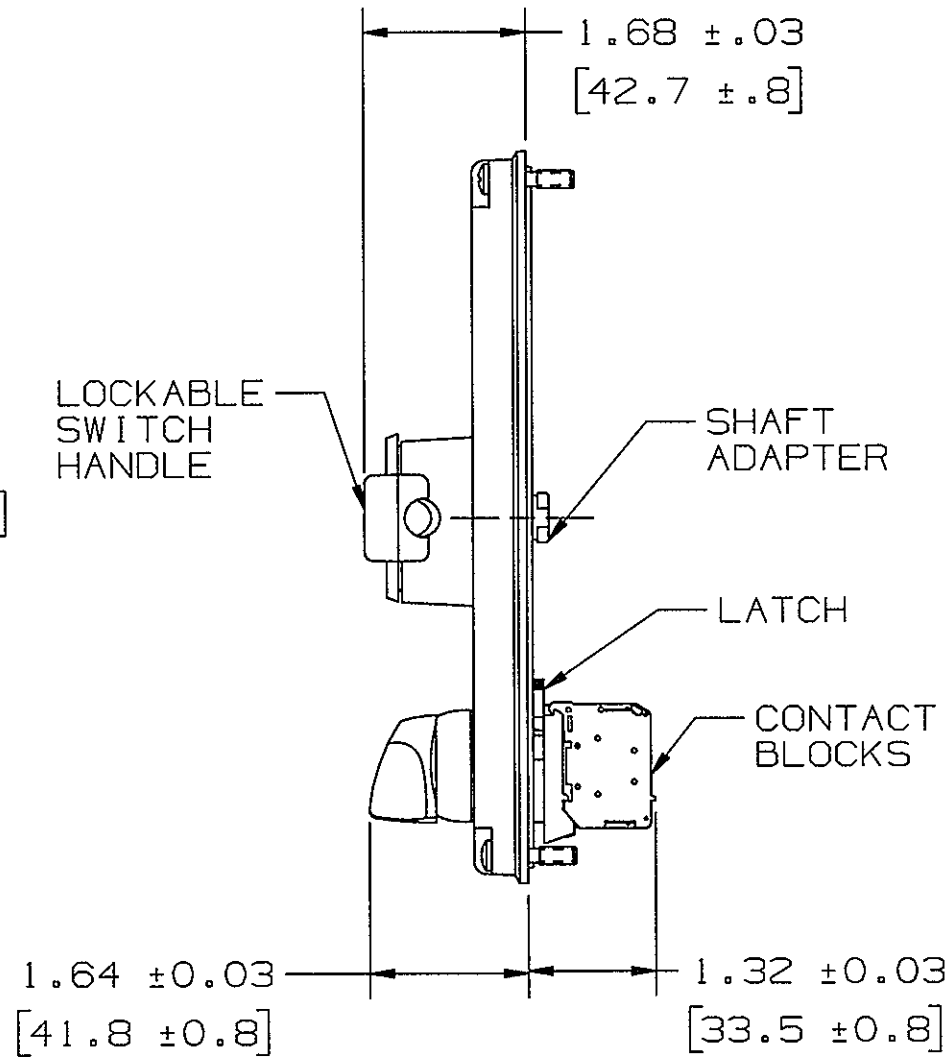
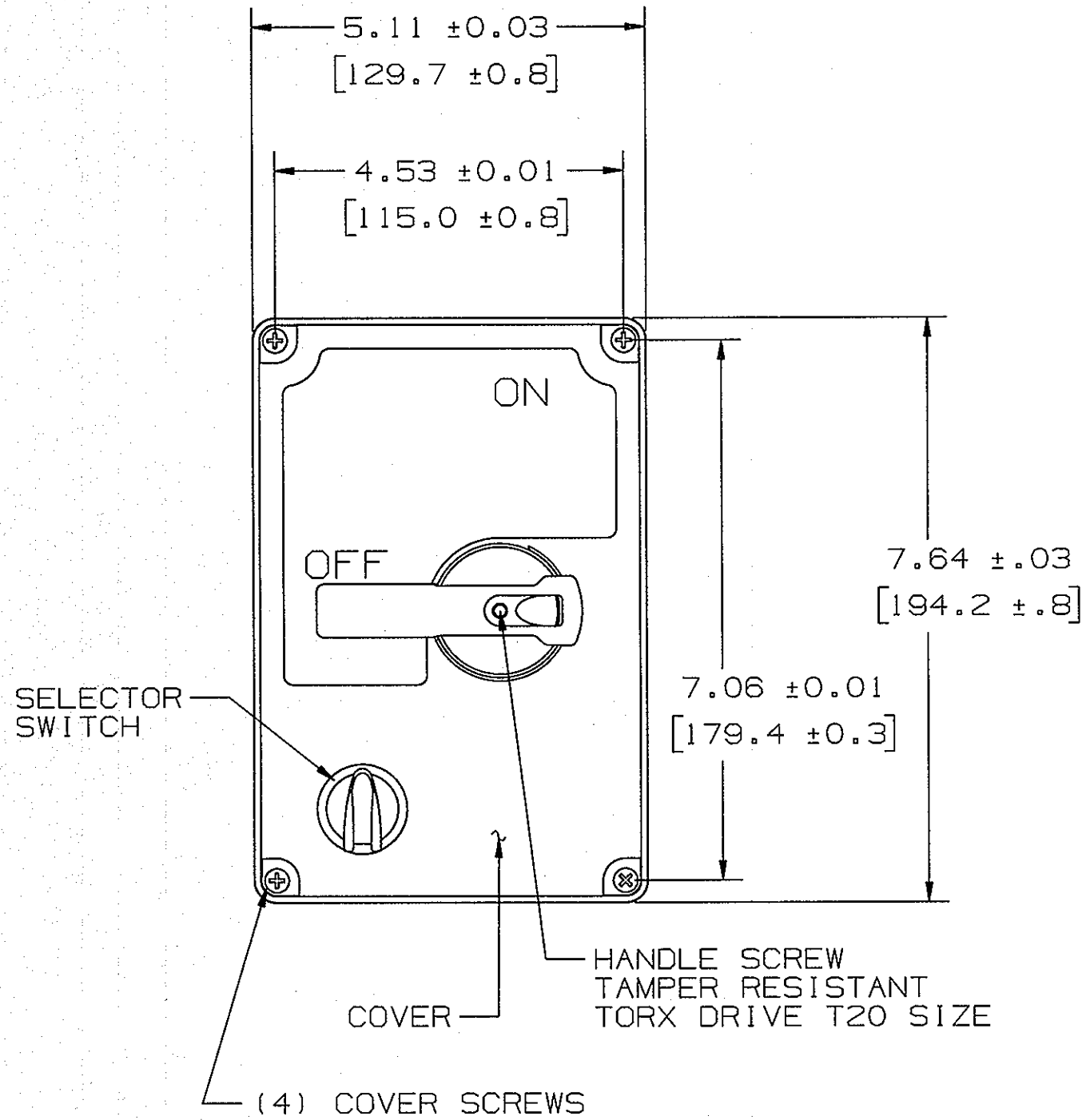

CATALOG NO.	REPLACEMENT COVER FOR
HBLDS3RCJ	HBLDS3J/HBLDS3ACJ

NOTES: UNLESS OTHERWISE SPECIFIED:  
1. DIMENSIONS IN INCHES [ mm ]

LIST OF PARTS		
DESCRIPTION	MATERIAL	FINISH
COVER	PBT	MT-11010
SHAFT ADAPTER	PBPT	SMOOTH
HANDLE	PBPT	MT-11010
(4) COVER SCREWS	ST. STEEL	
HANDLE SCREW	ST. STEEL	
SELECTOR SWITCH	PLASTIC	
LATCH	PLASTIC	
CONTACT BLOCKS	PLASTIC	

1	NEW RELEASE PER DCN #21935 CAC <i>CAC</i>	TLS	04/05/16
SYM	REVISIONS	APP	DATE

THE DESIGN AND DIMENSIONS OF THE PRODUCT SHOWN ON THIS DRAWING ARE SUBJECT TO CHANGE WITHOUT NOTICE

TITLE  
REPLACEMENT COVER ASSEMBLY

TOLERANCES UNLESS OTHERWISE SPECIFIED FRACTIONS ± 1/64 DECIMALS ± .005 ANGLES ± 2°	WIRING DEVICE-KELLEMS HUBBELL INCORPORATED BRIDGEPORT, CT	
	DR. BY CAC	APP. BY TLS
	TR. BY	SCALE HALF
	CHK'D BY TLS	DATE 04/05/16

DIMENSION SHEET FOR CAT. NO.

REPAIRABLE  NON-REPAIRABLE

B

M-13392

1