

M-13398

2

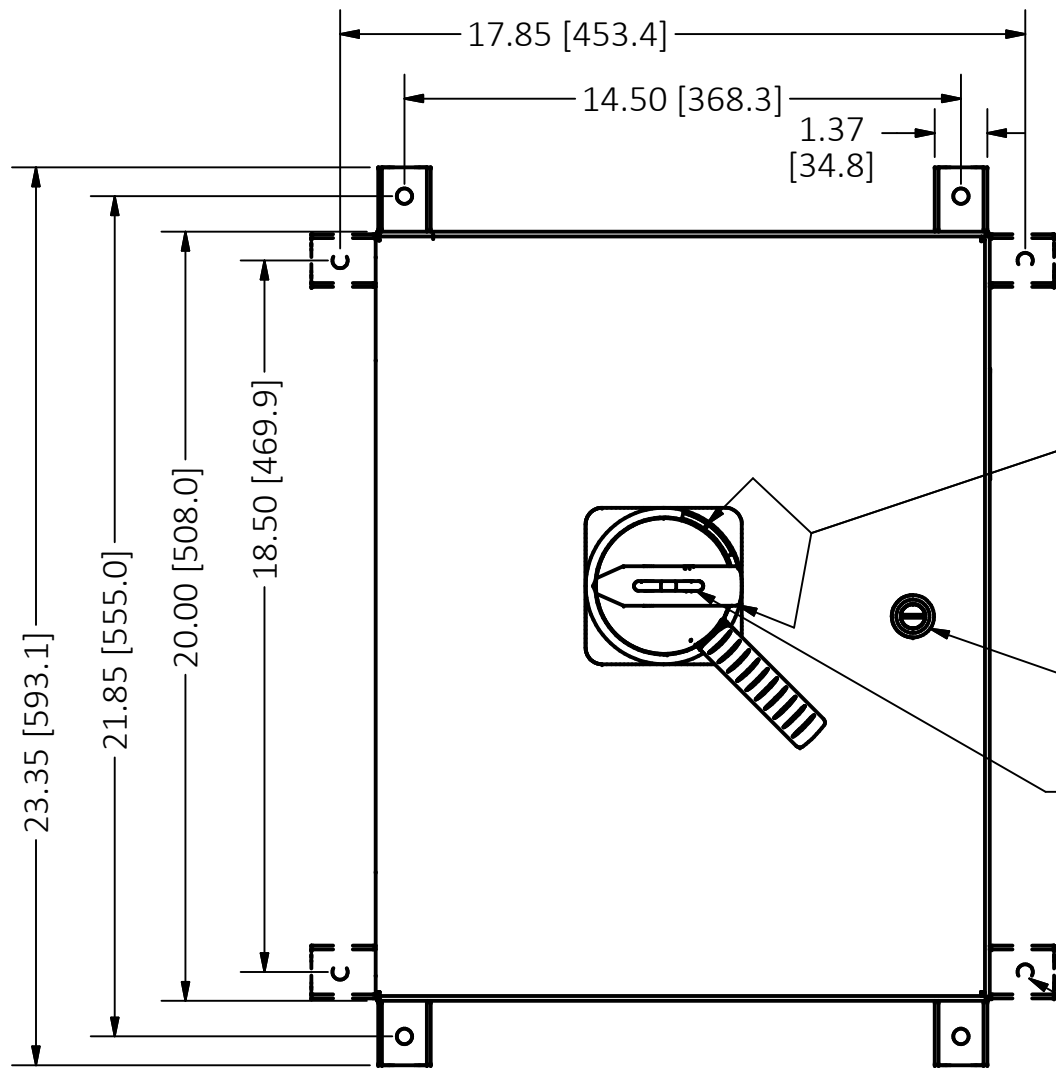
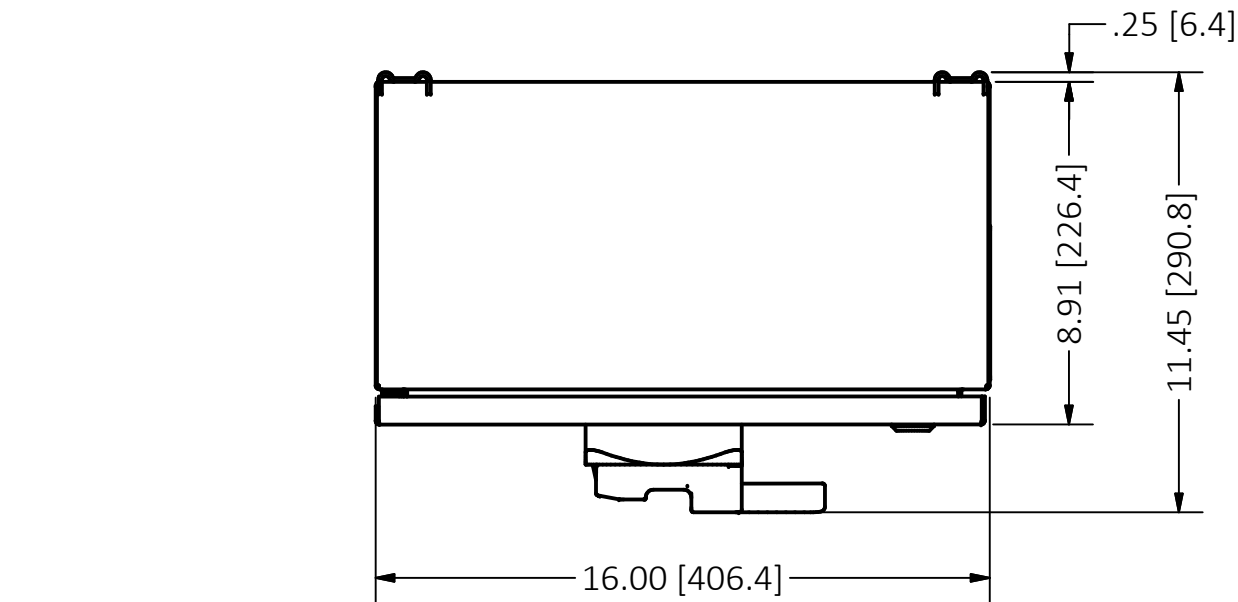

SHAFT SHOULD BE ORIENTED VERTICALLY IN ORDER TO MATE WITH HANDLE IN THE 'OFF' POSITION.

SWITCH TERMINAL CABLE CONNECTION = TORQUE TO 275 IN-LBS. [31 N-m]
3/8" MOUNTING HARDWARE = TORQUE TO 160 IN-LBS. [18 N-m]

GROUND TERMINAL CABLE CONNECTION = TORQUE TO 275 IN-LBS. [31 N-m]
1/2" MOUNTING HARDWARE = TORQUE TO 72 IN-LBS. [8 N-m]

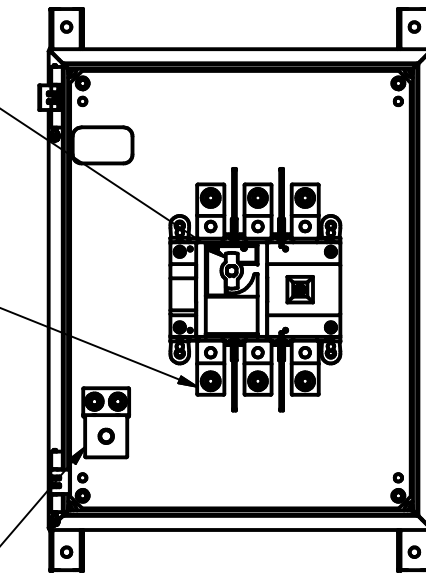

COVER NOT SHOWN FOR CLARITY

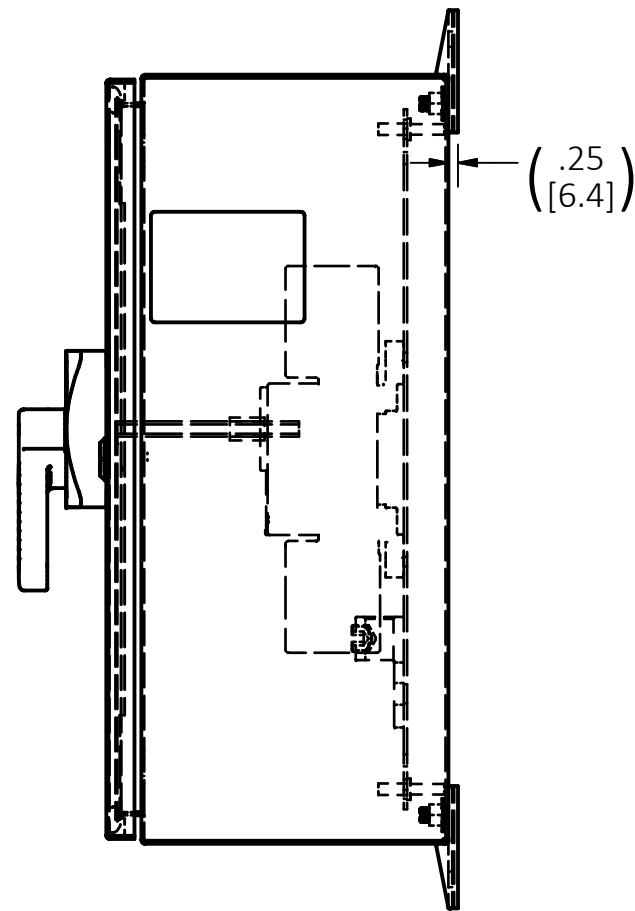

SQUEEZE LATCH AND HANDLE TO OPEN & CLOSE

1/4 TURN LATCH

LOCKOUT/TAG OUT LATCH
ø3/16" - ø5/16" [4.7mm-7.9mm]

MOUNTING FEET MAY BE ORIENTED HORIZONTALLY.

ACCEPTS UP TO ø3/8" [M10] FASTENER

NOTES:

- ENCLOSURE RATINGS - UL TYPE 4X
- PRODUCT RATING - LISTED TO UL STANDARD 98

CAGE CODE 74545

LIST OF PARTS

DESCRIPTION	MATERIAL	FINISH
ENCLOSURE	14 GA. 304 SST	SMOOTH GRAIN
HANDLE	PLASTIC	RED/YELLOW
SWITCH	PLASTIC	-
BACKPLATE	14 GA. 304 SST	304 ANN 2 B
TERMINALS	ALUMINUM	TIN PLATED
FASTENERS	STEEL	ZINC PLATED
MOUNTING FEET	304 SST	-

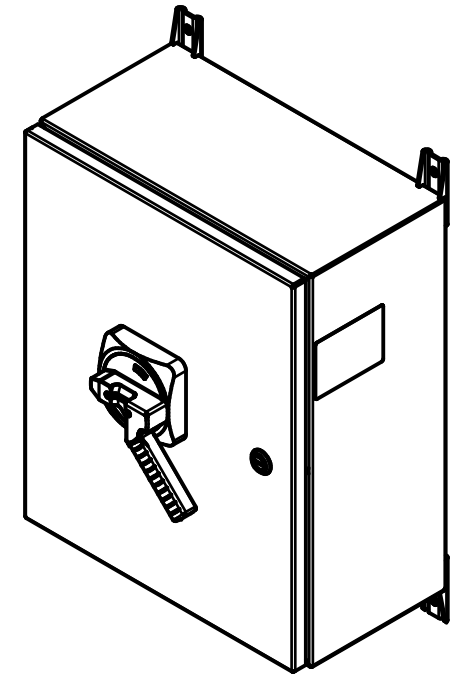

CATALOG NO. HBLD20SS
(NOT TO SCALE)

REV	DESCRIPTION	APP	DATE
2	MODIFIED PRODUCT LABEL LOCATION PER DCN# 22731		11/30/16
1	NEW DRAWING RELEASED FOR PRODUCTION PER DCN# 22326		8/2/16

THE DESIGN AND DIMENSIONS OF THE PRODUCT SHOWN ON THIS DRAWING ARE SUBJECT TO CHANGE WITHOUT NOTICE. DIMENSIONS ARE IN INCHES [mm].

TITLE
200A DISCONNECT, SST



WIRING DEVICE-KELLEMS
HUBBELL INCORPORATED
SHELTON, CT

TOLERANCES UNLESS OTHERWISE SPECIFIED .XX = ±.10 .XXX = ±.030 ANGLE TOL. ±2	DR. BY MS	SCALE 1/5
	CHK. BY TLS	DATE 8/2/16

DIMENSION SHEET FOR CAT. NO. HBLD20SS

B

M-13398

2