

M-13446

2

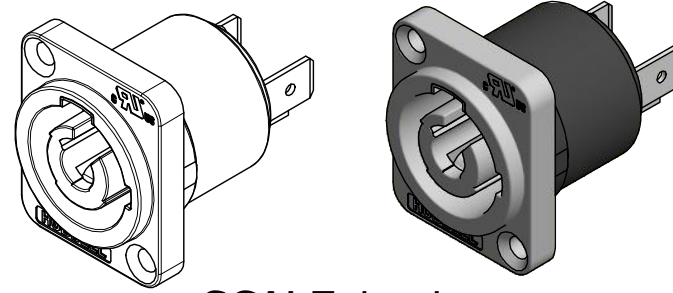

SCALE 1 : 1

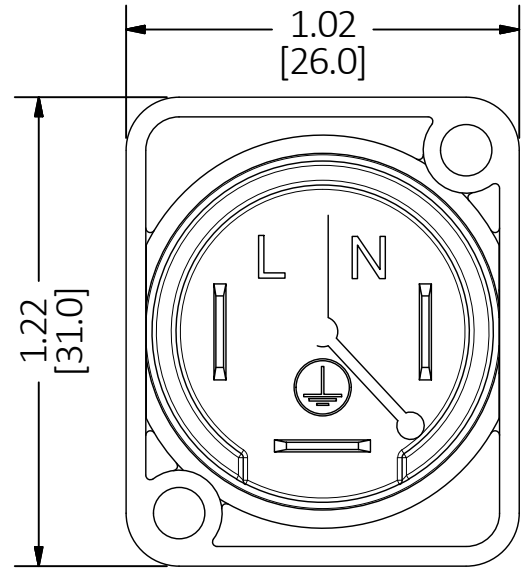
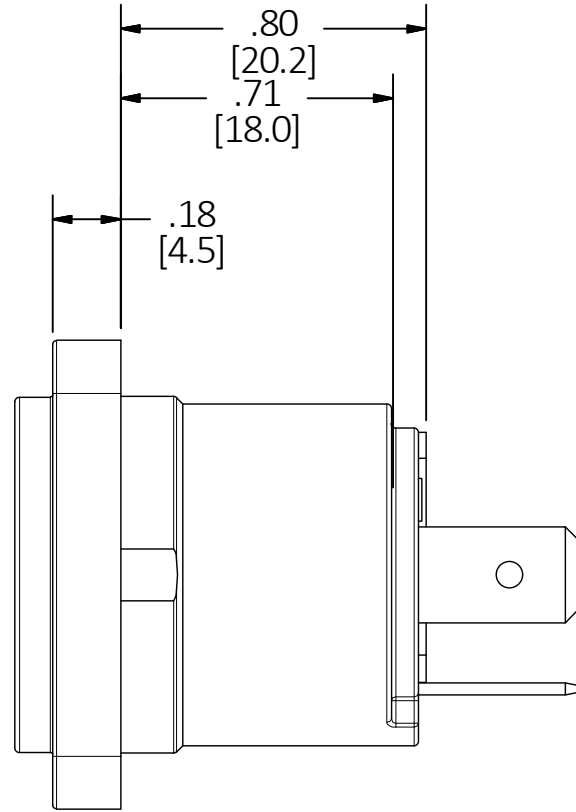
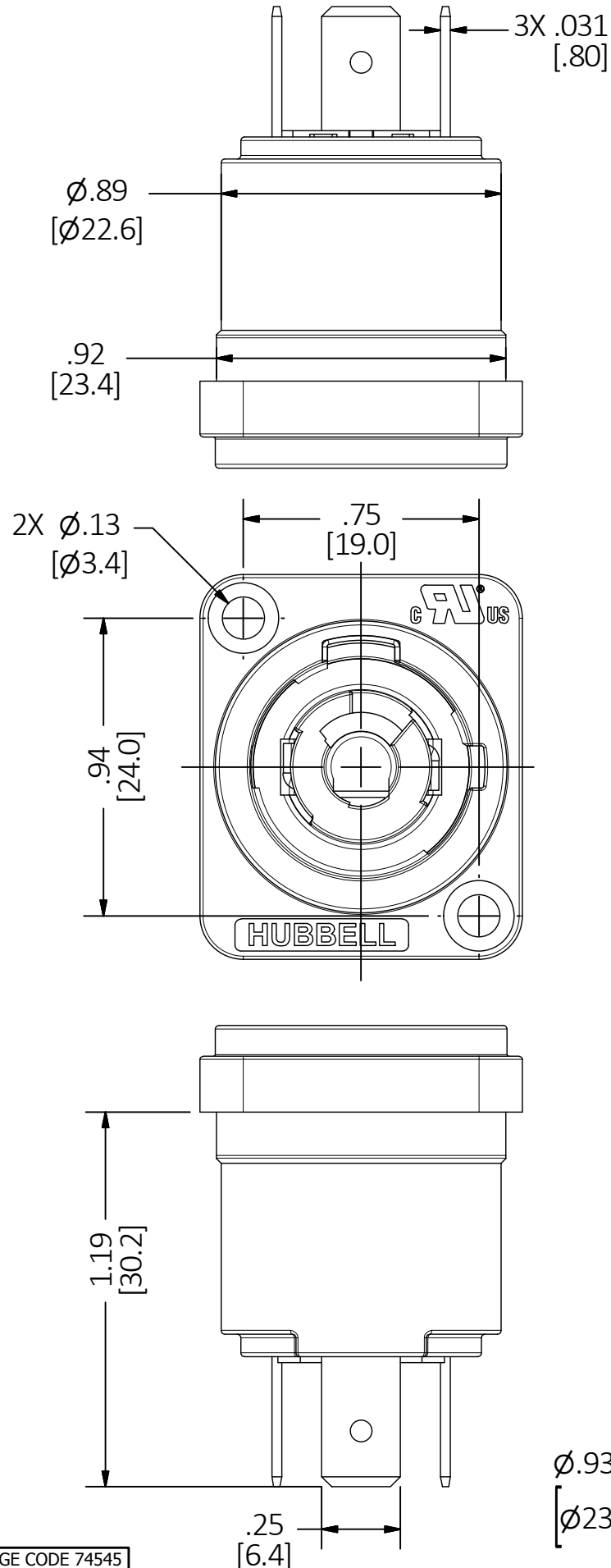
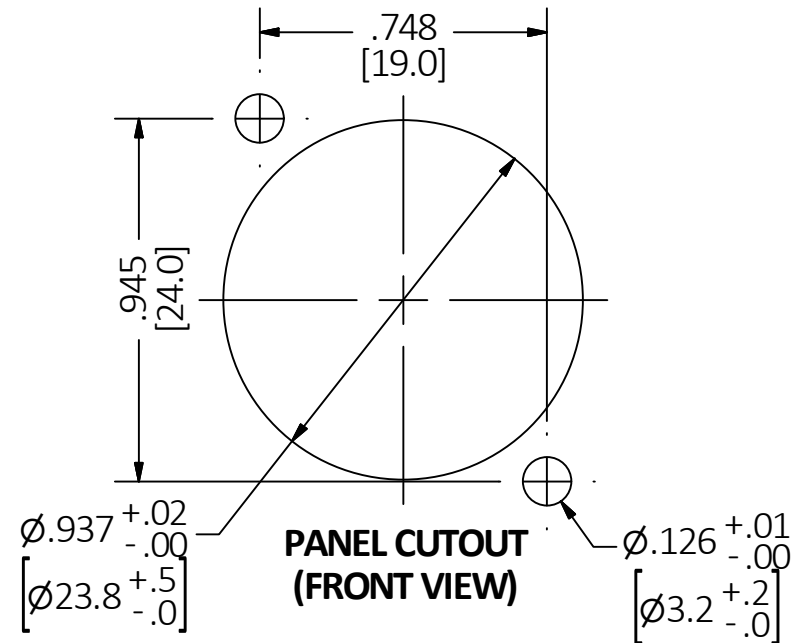

NOTES:

1. DIMENSIONS ARE IN INCHES (mm).
2. DEVICES ARE WITHOUT "BREAKING CAPACITY". THE CONNECTORS SHOULD NOT BE CONNECTED OR DISCONNECTED LIVE OR WHEN UNDER LOAD.
3. cULus RECOGNIZED COMPONENTS FOR USA AND CANADA IN CATEGORIES ECBT2 & ECBT8 RESPECTIVELY.
4. LOCKABLE 3-POLE SINGLE PHASE AC PANEL MOUNT.
5. RATED 25A MAX AT 125 VAC OR 250 VAC.
6. 1/4 inch (6.4 mm) FLAT TAB TERMINALS.
7. FOR USE WITH Insul-Lock™ CATALOG NUMBER HBLCPGY.

LIST OF PARTS

DESCRIPTION	MATERIAL	FINISH
PANEL MOUNT FACE	PA66 GF30	GREY
REAR HOUSING	PBT & SANTOPRENE	BLACK
CONTACTS	COPPER ALLOY	SILVER
LATCH PLATE	STEEL	NICKEL

REV	DESCRIPTION	APP	DATE
2	ADDED Insul-Lock™ TO TITLE & NOTE 7 PER DCN 22334 MAM	TLS	12/5/16
1	PER DCN 22330	TLS	8/12/16

THE DESIGN AND DIMENSIONS OF THE PRODUCT SHOWN ON THIS DRAWING ARE SUBJECT TO CHANGE WITHOUT NOTICE. DIMENSIONS ARE IN INCHES [mm].

TITLE
CUSTOMER DRAWING, Insul-Lock™, PANEL MOUNT, POWER OUT, GREY

WIRING DEVICE-KELLEMS HUBBELL INCORPORATED SHELTON, CT

TOLERANCES UNLESS OTHERWISE SPECIFIED .XX = ±.01 .XXX = ±.005 ANGLE TOL. ±2'	DR. BY MAM	SCALE 2 : 1
	CHK. BY TLS	DATE 8/12/16

DIMENSION SHEET FOR CAT. NO. HBLPMOgy

B

M-13446

2