

M-13512

1

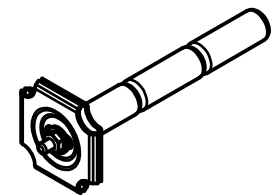
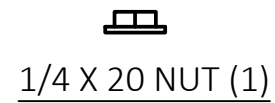
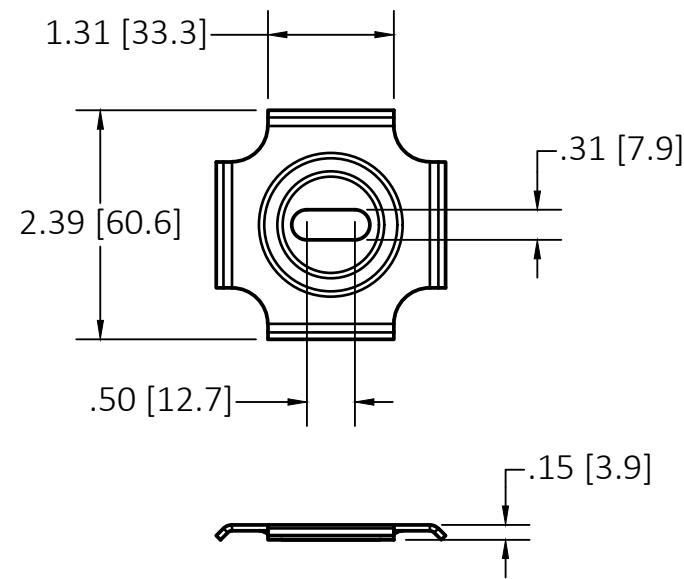
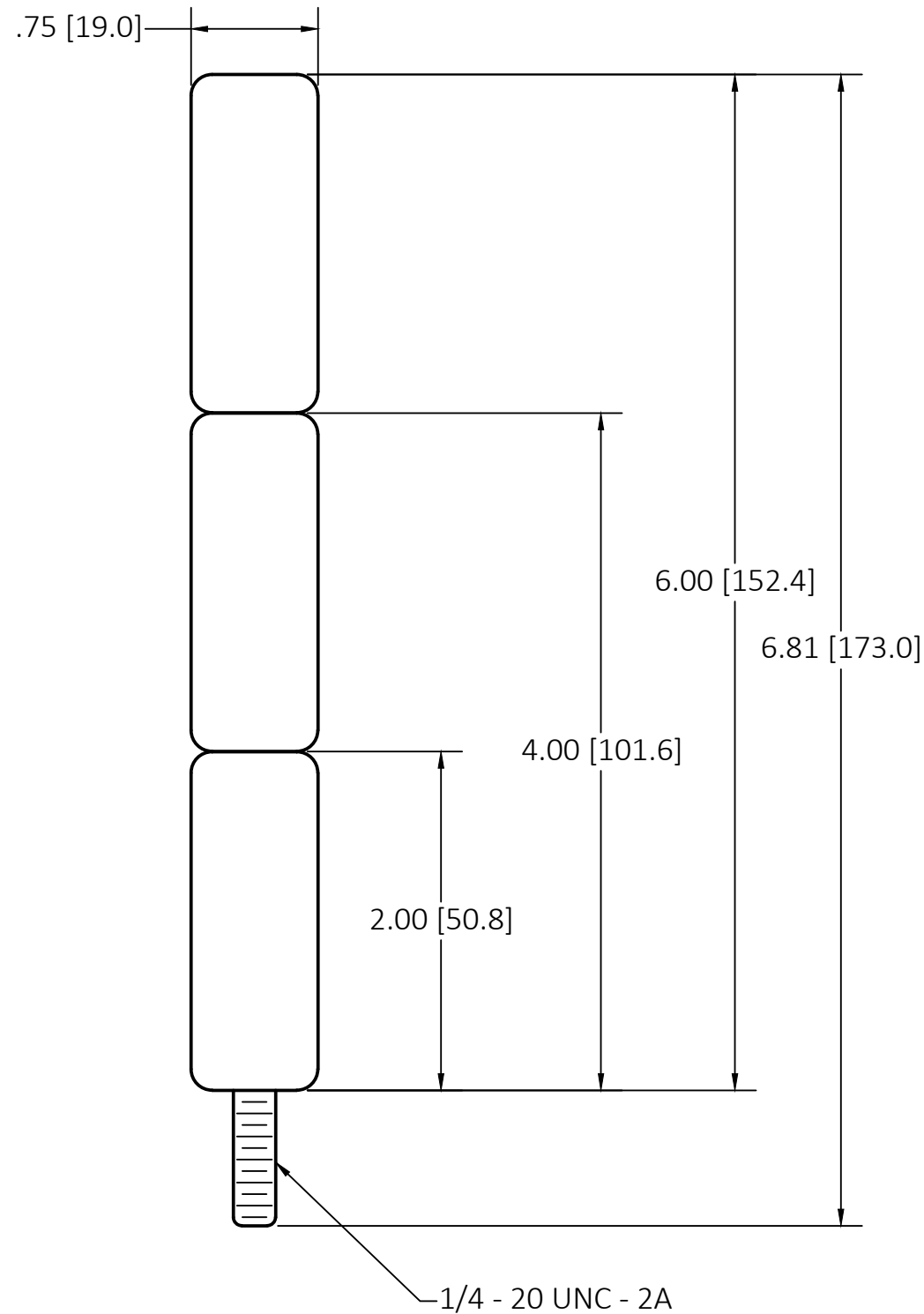

CATALOG NO. HBTCG
(NOT SHOWN TO SCALE)

LIST OF PARTS		
DESCRIPTION	MATERIAL	FINISH
GUIDE		BLACK
WASHER SUPPORT	STEEL	PRE-GALVANIZED
NUT	STEEL	PRE-GALVANIZED

1	INITIAL DOCUMENT RELEASE PER DCN 22750	DDL	11/15/16
REV	DESCRIPTION	APP	DATE

THE DESIGN AND DIMENSIONS OF THE PRODUCT SHOWN ON THIS DRAWING ARE SUBJECT TO CHANGE WITHOUT NOTICE. DIMENSIONS ARE IN INCHES [mm].

TITLE
CABLE GUIDE

 WIRING DEVICE-KELLEMS
HUBBELL INCORPORATED
SHELTON, CT

TOLERANCES UNLESS OTHERWISE SPECIFIED .XX = ± .01 .XXX = ± .005 ANGLE TOL. ± 2°	DR. BY BJ	SCALE NONE
	CHK. BY MN	DATE 08/16/16

NOTES:
1. MAINTAINS CABLE BEND RADIUS AND ACTS AS A DIVIDER FOR STRAIGHT SECTION AND FITTINGS