

M-14441

1

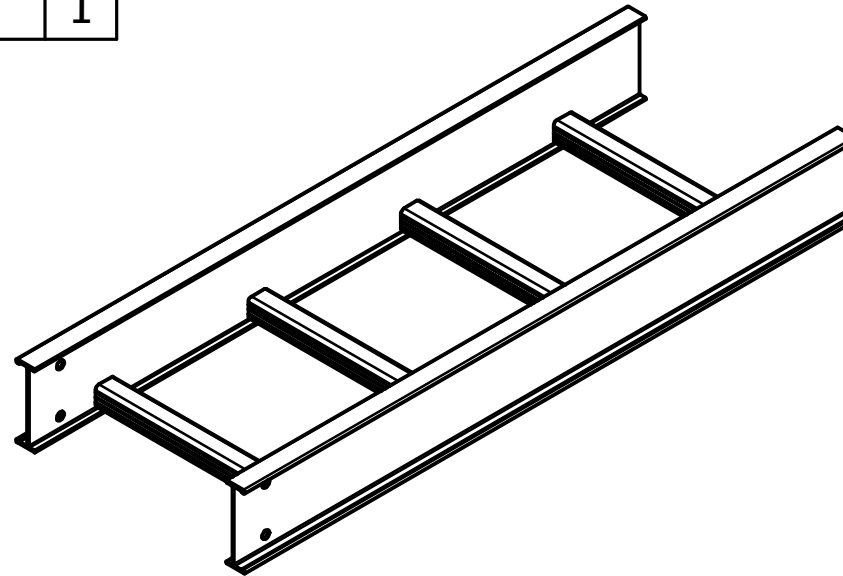
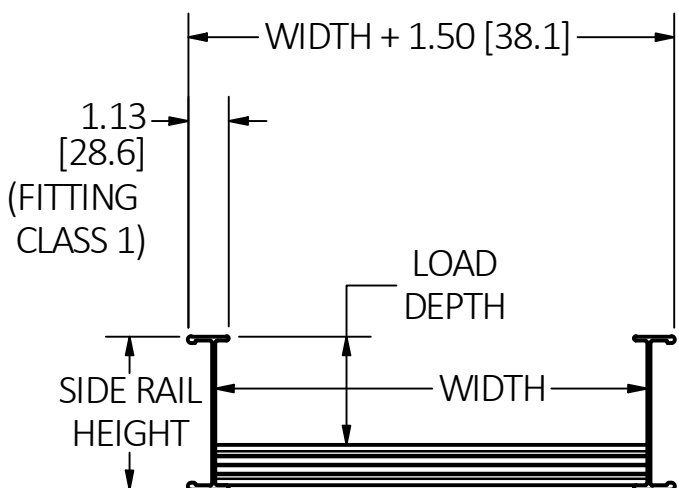
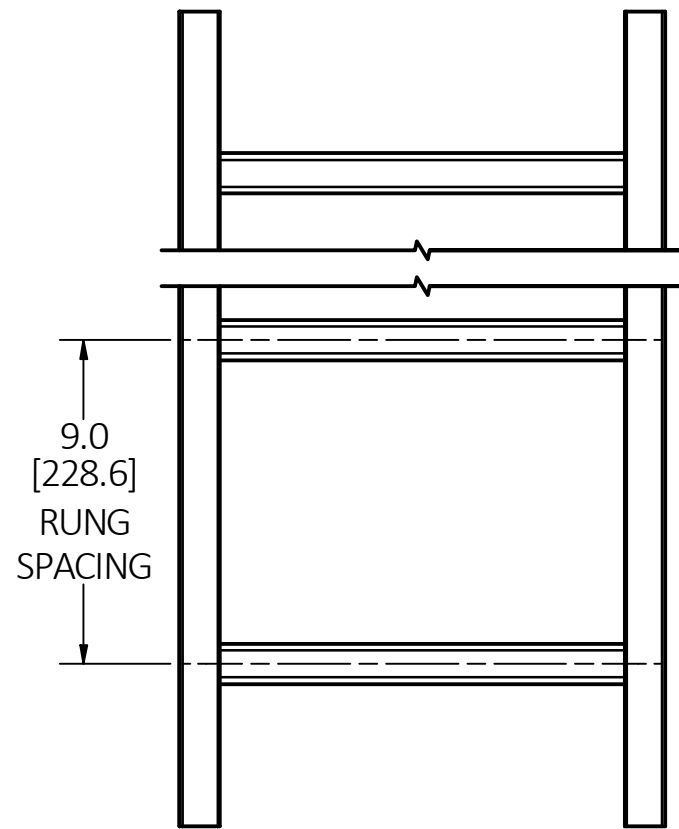

CATALOG NUMBER	SIDE RAIL HEIGHT NOMINAL (in [mm])	SIDE RAIL HEIGHT ACTUAL (in [mm])	LOAD DEPTH (in [mm])	WIDTH (in [mm])	NEMA SAFE LOAD (Lb/ft)	UL AREA (Sq. In.)	AMP RATING	NEMA LOAD CLASS	CSA LOAD CLASS
LTB412	4 [101.6]	4.25 [108.0]	3 [76.2]	12 [304.8]	81	.60	1000	12B	C
LTB418	4 [101.6]	4.25 [108.0]	3 [76.2]	18 [457.2]	81	.60	1000	12B	C
LTB424	4 [101.6]	4.25 [108.0]	3 [76.2]	24 [609.6]	81	.60	1000	12B	C
LTC412	4 [101.6]	4.25 [108.0]	3 [76.2]	12 [304.8]	100	.60	1000	12C	D-3M
LTC418	4 [101.6]	4.25 [108.0]	3 [76.2]	18 [457.2]	100	.60	1000	12C	D-3M
LTC424	4 [101.6]	4.25 [108.0]	3 [76.2]	24 [609.6]	100	.60	1000	12C	D-3M
LTB612	6 [152.4]	6.25 [158.8]	5 [127.0]	12 [304.8]	89	1.00	1200	12B	D-3M
LTB618	6 [152.4]	6.25 [158.8]	5 [127.0]	18 [457.2]	89	1.00	1200	12B	D-3M
LTB624	6 [152.4]	6.25 [158.8]	5 [127.0]	24 [609.6]	89	1.00	1200	12B	D-3M
LTC612	6 [152.4]	6.25 [158.8]	5 [127.0]	12 [304.8]	105	1.00	1200	12C	D-3M
LTC618	6 [152.4]	6.25 [158.8]	5 [127.0]	18 [457.2]	105	1.00	1200	12C	D-3M
LTC624	6 [152.4]	6.25 [158.8]	5 [127.0]	24 [609.6]	105	1.00	1200	12C	D-3M

NOTES:

1. ALL DIMENSIONS ARE IN INCHES AND [MILLIMETERS].
2. PRODUCT IS cULus CLASSIFIED.
3. LENGTH OF LADDER TRAY IS 12 ft (3.66 m).
4. USE CLASS 1 FITTINGS.
5. SUPPLIED WITH (2) SPLICE PLATES, FASTENERS: (8) \varnothing 3/8" X 3/4" LONG SCREWS & (8) \varnothing 3/8" FLANGED HEX NUTS.
6. INSTALL IN ACCORDANCE WITH NEMA STANDARD VE-2 "CABLE TRAY INSTALLATION GUIDELINES".
7. WARNING! DO NOT USE AS A WALKWAY, LADDER OR SUPPORT FOR PERSONNEL. USE ONLY AS A MECHANICAL SUPPORT FOR CABLES, TUBING, AND RACEWAYS.

CAGE CODE 74545

LIST OF PARTS

DESCRIPTION	MATERIAL	FINISH
TRAY	ALUMINUM	
SPLICE PLATE	ALUMINUM	
SCREWS	STEEL	GEOMET PLATED
NUTS	STEEL	GEOMET PLATED

DIMENSION SHEET FOR CAT. NO.
SEE TABLE

B

M-14441

1

1	RELEASED PER DCN211021013702	AD	10/21/21
---	---------------------------------	----	----------

REV	DESCRIPTION	APP	DATE
-----	-------------	-----	------

THE DESIGN AND DIMENSIONS OF THE PRODUCT SHOWN ON THIS DRAWING ARE SUBJECT TO CHANGE WITHOUT NOTICE. DIMENSIONS ARE IN INCHES [mm].

TITLE

ALUMINUM LADDER TRAY



WIRING DEVICE-KELLEMS
HUBBELL INCORPORATED
SHELTON, CT

TOLERANCES UNLESS OTHERWISE SPECIFIED .XX = ±.01 .XXX = ±.005 ANGLE TOL. ±2'	DR. BY AD	SCALE NONE
	CHK. BY SBW	DATE 10/13/21