

M-8256 | 1

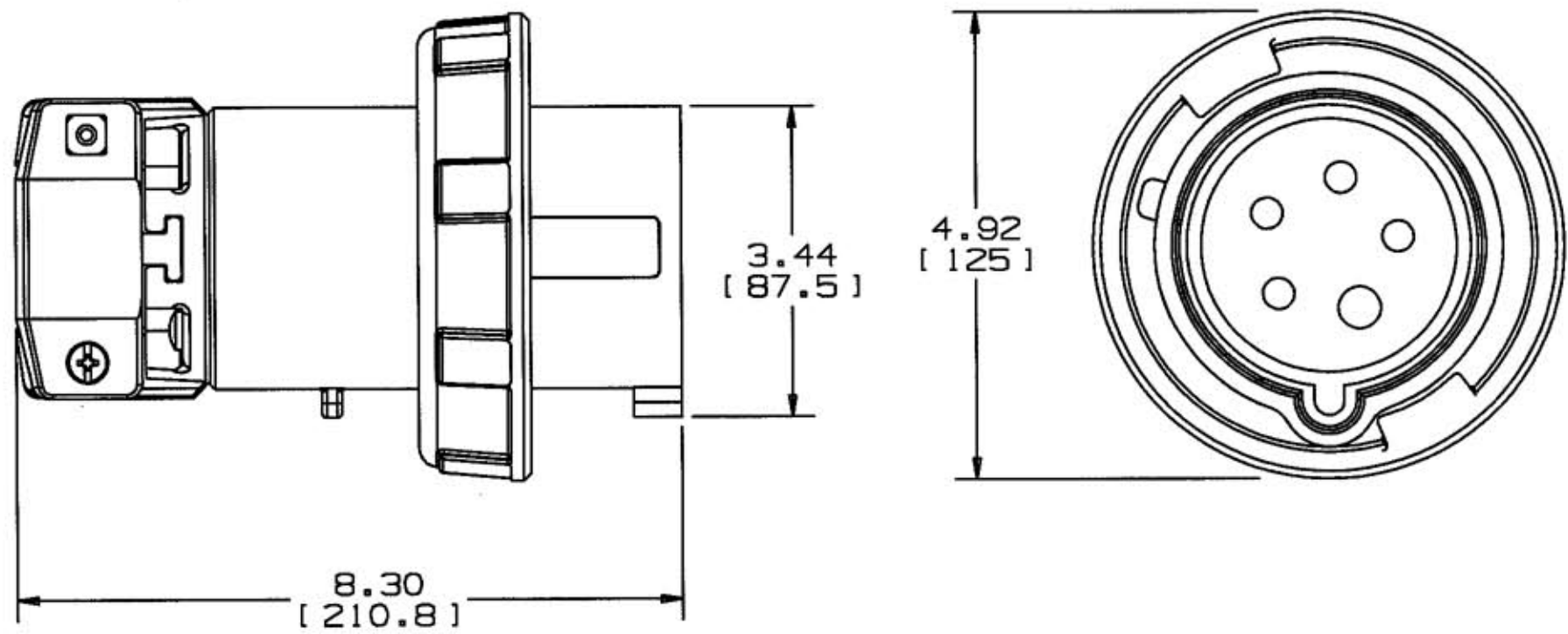

- NOTES:
1. DIMENSIONS ARE IN INCHES [MM]
 2. ONE 5MM HEX KEY INCLUDED.
 3. .XX TOLERANCE TO BE ±.03

LIST OF PARTS

DESCRIPTION	MATERIAL	FINISH
HOUSING	NYLON	BLUE
LOCKING RING	POLYESTER	-
CLAMP	POLYESTER	-
PINS	BRASS	-
TERMINAL SCREWS	STAINLESS STEEL	-
GASKET	NEOPRENE	-
CLAMP NUT	BRASS	NICKEL PLATE
CLAMP SCREW	STAINLESS STEEL	-
KEY	STEEL	BLACK

DIMENSION SHEET FOR CAT. NO. HBL5100P9WSH

REPAIRABLE NON-REPAIRABLE

1	RELEASED PER DCN#13080. ABS	APP	5/15/06
SYM	REVISIONS	APP	DATE

THE DESIGN AND DIMENSIONS OF THE PRODUCT SHOWN ON THIS DRAWING ARE SUBJECT TO CHANGE WITHOUT NOTICE

TITLE
100A, 3Ø Y 120/208VAC, 4P5W
PIN & SLEEVE PLUG

TOLERANCES UNLESS OTHERWISE SPECIFIED FRACTIONS ±1/64 DECIMALS ±.005 ANGLES ±2°	WIRING DEVICE-KELLEMS HUBBELL INCORPORATED BRIDGEPORT, CT	
	DR. BY RTK	APP. BY <i>[Signature]</i>
	TR. BY	SCALE N/A
	CHK'D BY <i>[Signature]</i>	DATE 8/4/99

B

M-8256

1