

M-8752 1

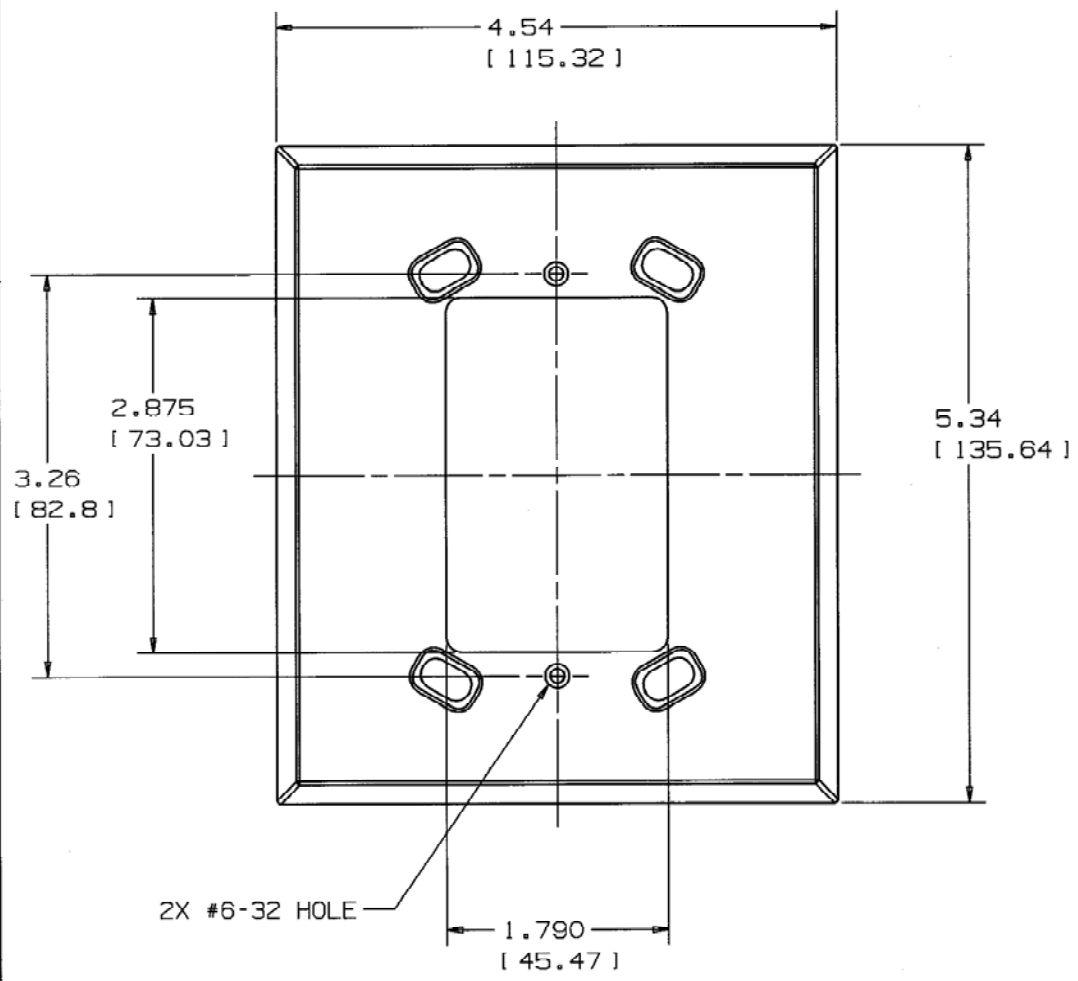

LIST OF PARTS		
DESCRIPTION	MATERIAL	FINISH
ADAPTER PLATE	23G STEEL	ZINC PLATE PAINTED WHITE
4x #6-32x25mm FL.HD.	STEEL	NICKEL PLATE
2x #6-32x12mm FL.HD.	STEEL	NICKEL PLATE
2x #6-32x4mm FL.HD.	STEEL	NICKEL PLATE
2x PLASTIC SCREW CAP		

DIMENSION SHEET FOR CAT. NO. WSAP REPAIRABLE  NON-REPAIRABLE  B M-8752 1

1	INITIAL RELEASE DCN#9357	3-18-02
SYM	REVISIONS	APP DATE

THE DESIGN AND DIMENSIONS OF THE PRODUCT SHOWN ON THIS DRAWING ARE SUBJECT TO CHANGE WITHOUT NOTICE

TITLE  
DOUBLE GANG TO SINGLE GANG ADAPTER PLATE

TOLERANCES UNLESS OTHERWISE SPECIFIED		WIRING DEVICE-KELLEMS HUBBELL INCORPORATED BRIDGEPORT, CT	
FRACTIONS	± 1/64	DR. BY	PAC APP. BY JVP
DECIMALS	± .005	TR. BY	SCALE 1-1
ANGLES	± 2'	CHK'D BY	DATE 3-18-02