

M-9915 1

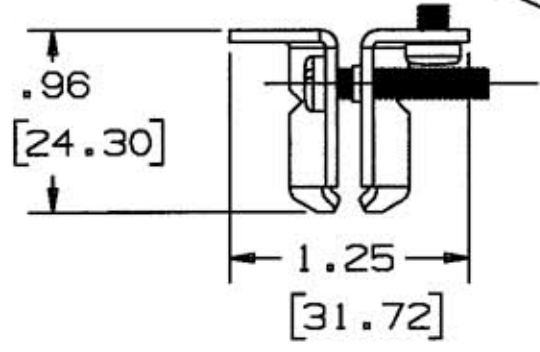
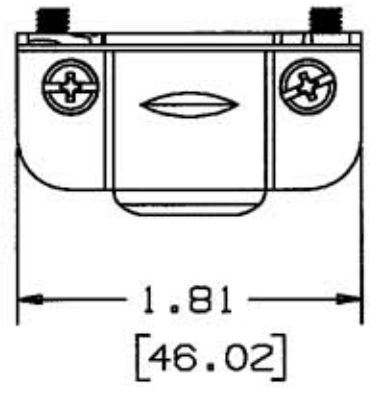
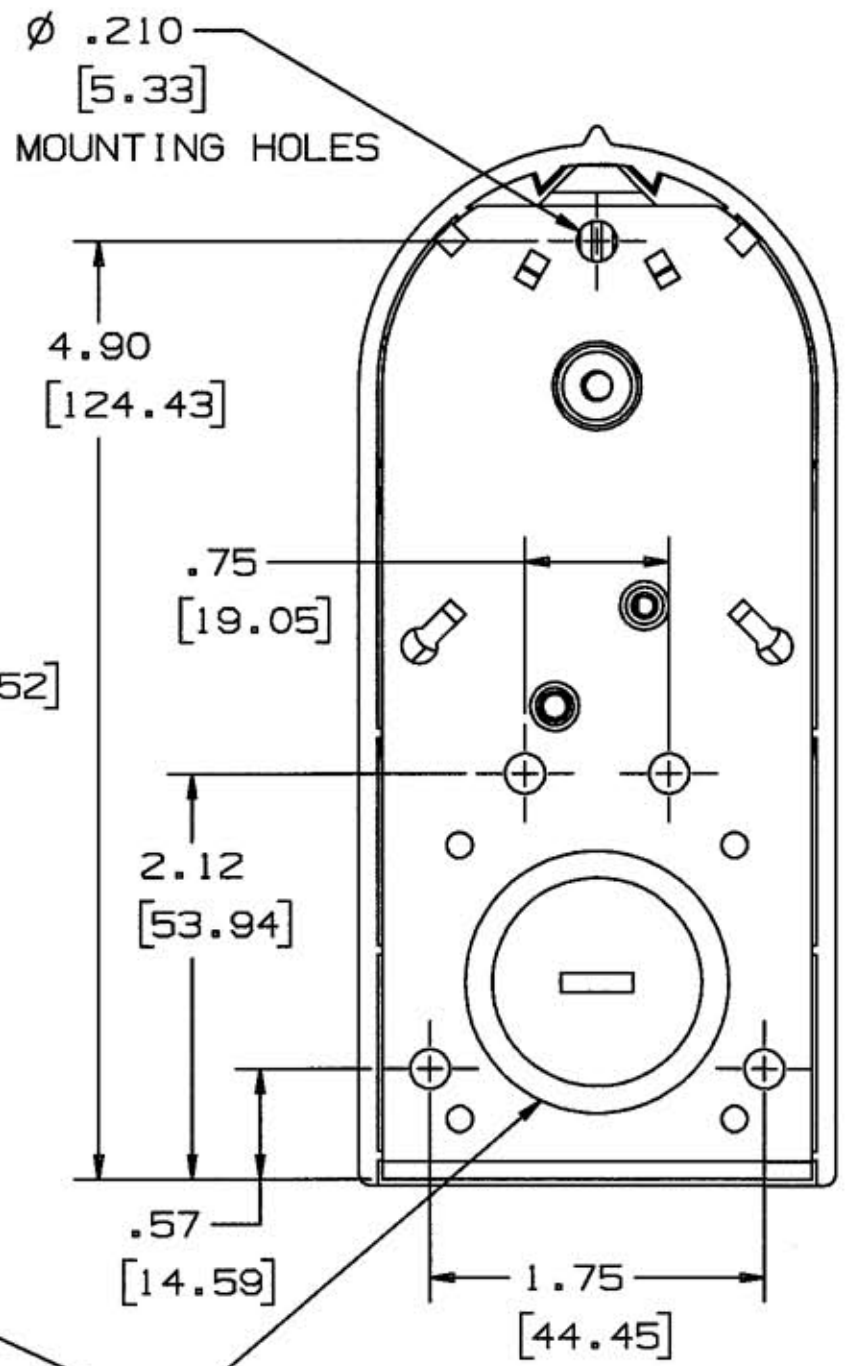
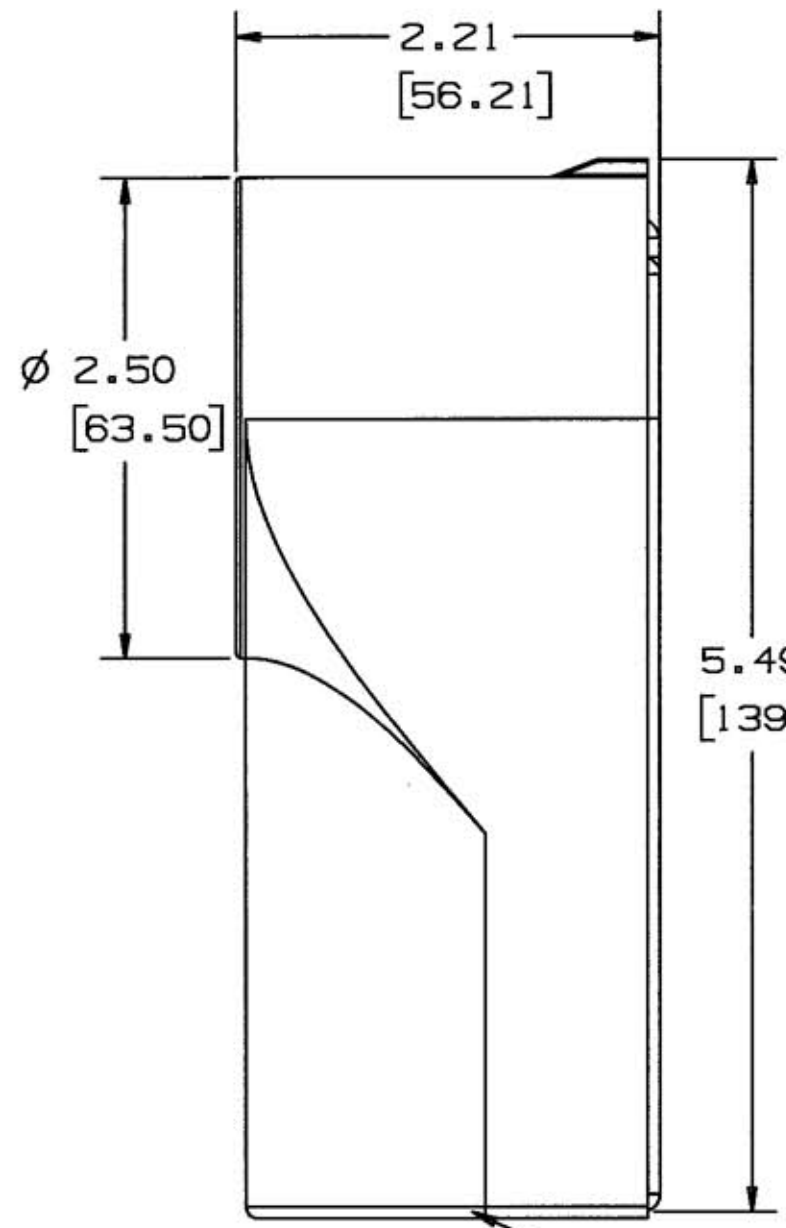
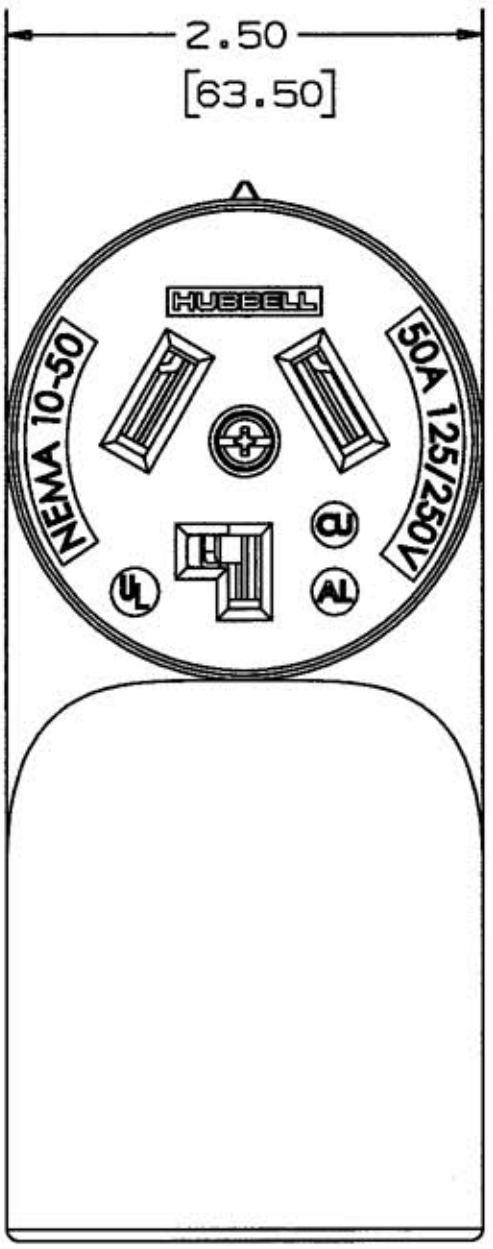

KNOCKOUTS FOR 3/4" AND 1" CONDUIT IN BOTTOM AND BACK

- NOTES: (UNLESS OTHERWISE SPECIFIED)
1. AWG CAPACITY: #4-#10
  2. FOR USE WITH ALUMINUM AND COPPER WIRE SOLID OR STRANDED
  3. DIMENSIONS ARE IN INCHES [MM].

CODE 74545

LIST OF PARTS

DESCRIPTION	MATERIAL	FINISH
WIRE BASE PLATE	STEEL	ZINC
CORD CLAMPS BOTTOM	STEEL	ZINC
CONTACT BLADES	BRASS	
CONTACT SPRING 30A	BRASS	
CONTACT BASE	PLASTIC	
COVER	PLASTIC	
SCREWS	STEEL	ZINC

SYM	REVISIONS	APP	DATE
1	RELEASE PER DCN#13429		11/27/06

THE DESIGN AND DIMENSIONS OF THE PRODUCT SHOWN ON THIS DRAWING ARE SUBJECT TO CHANGE WITHOUT NOTICE

TITLE  
SURFACE MOUNT RECEPTACLE  
NEMA 10-30R

TOLERANCES UNLESS OTHERWISE SPECIFIED	WIRING DEVICE-KELLEMS HUBBELL INCORPORATED BRIDGEPORT, CT.	
FRACTIONS ± 1/64	DR. BY MPF	APP. BY [Signature]
DECIMALS ± .005	TR. BY [Signature]	SCALE 1/1
ANGLES ± 2°	CHK'D BY [Signature]	DATE 10/3/05

DIMENSION SHEET FOR CAT. NO. RR330  
 REPAIRABLE  NON-REPAIRABLE  B M-9915 1