

DRAWING NO.
SA049180-01

| REV | DATE | DESCRIPTION | ECO | BY | C'H'K. |
|-----|------------------------|----------------------|-------|----|--------|
| A | 08/12/2013 00:00:00 AM | REDRAW SALES DRAWING | 29515 | BD | MB |

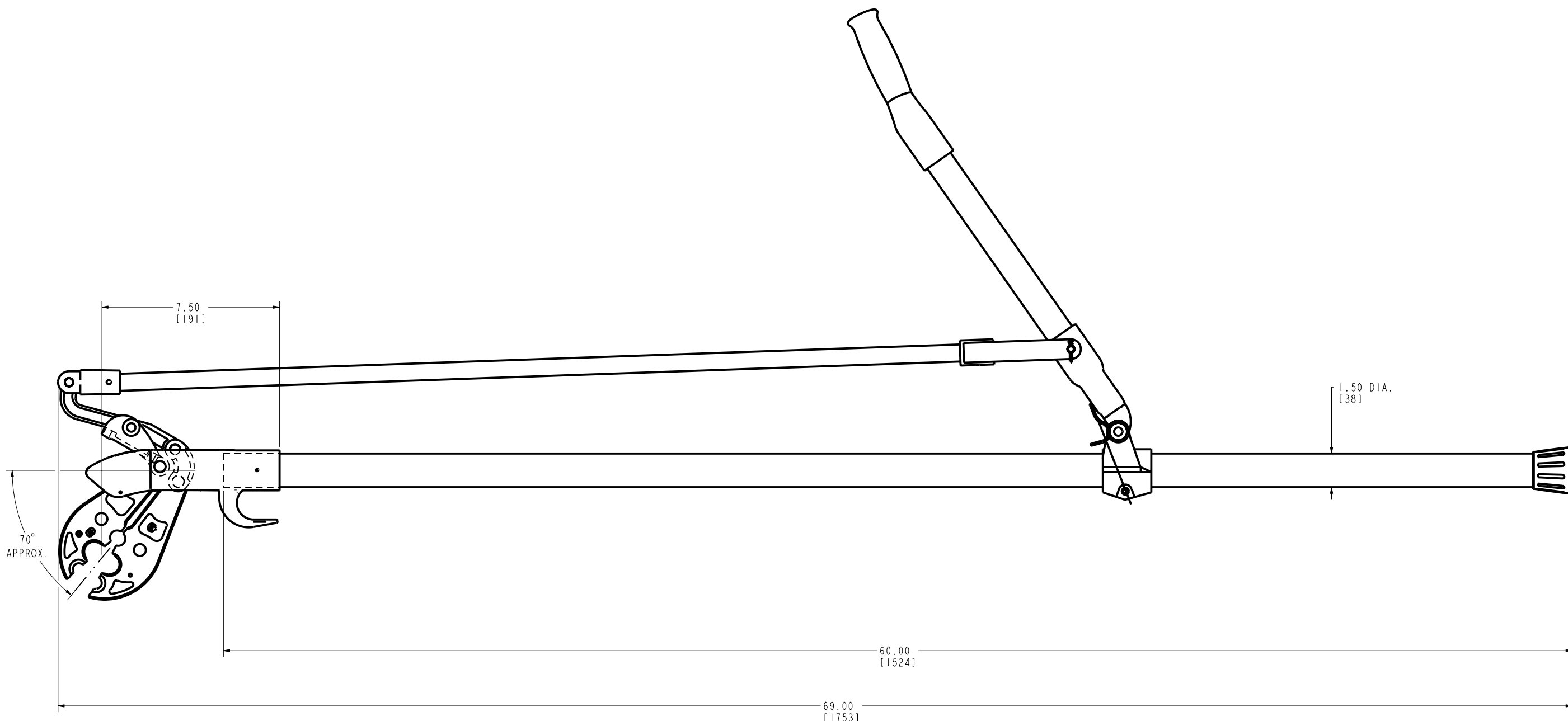

NOTES:

1. MATERIAL: FORGED STEEL CRIMPING JAWS
CAST ALUMINUM FRAME AND PIVOT MEMBERS.
FIBER GLASS HOTSTICK AND CONTROL ROD.
2. ELECTRICAL TEST:
FIBER GLASS HOTSTICK POLE AND CONTROL
ROD TESTED TO 100 KV/FT. FOR 5 MIN.
3. WEIGHT: 15.5 LBS
4. REFERENCE: SD049808 (INSTRUCTION SHEET)
5. DIMENSIONS IN BRACKETS [] ARE IN MILLIMETERS ROUNDED OFF TO THE NEAREST MILLIMETER,
UNLESS OTHERWISE NOTED, AND ARE FOR REFERENCE ONLY.

REV: PE0200

| | | | |
|--------------------------------------------------------------------------------------------------------------------------------------------------------------------------------------------------------------------------------------------------|----------|-----------------|------------------|
| TO ORDER BURNDY® PRODUCTS CALL UNITED STATES 1-800-346-4175 (LONDONDERRY, NH) CANADA: 1-800-361-6975 (QUEBEC) 1-800-387-6487 (ALL OTHER PROVINCES) FOR PRODUCT INFO: http://www.burndy.com | | MD6 HOTSTICK | |
| | | ITEM NO: 464030 | CAT. NO: MD6HS60 |
| DRAWN BY: JMC | 7/19/61 | | |
| CHECKER: MJM | 7/19/61 | | |
| DSN APPVL: WR | 7/19/61 | | |
| MFG APPVL: WP | 11/20/61 | | |
| QA APPVL: -- | -- | | |
| MKT APPVL: -- | -- | SCALE: 1:1 | |
| PROD FAM: -- | -- | DRAWING NO | REV |
| PROJECT #: -- | SIZE | SA049180-01 | A |
| DOCUMENT TYPE: Sales | D | SHEET 1 OF 1 | |
| REL LEVEL: Released | | | |