

REV	DATE	DESCRIPTION	ECO	BY	C.H.K.
D	2016-01-28 00:00:00 EST	DRAWING UPDATED AS PER MARKUP	42809	RM	RG

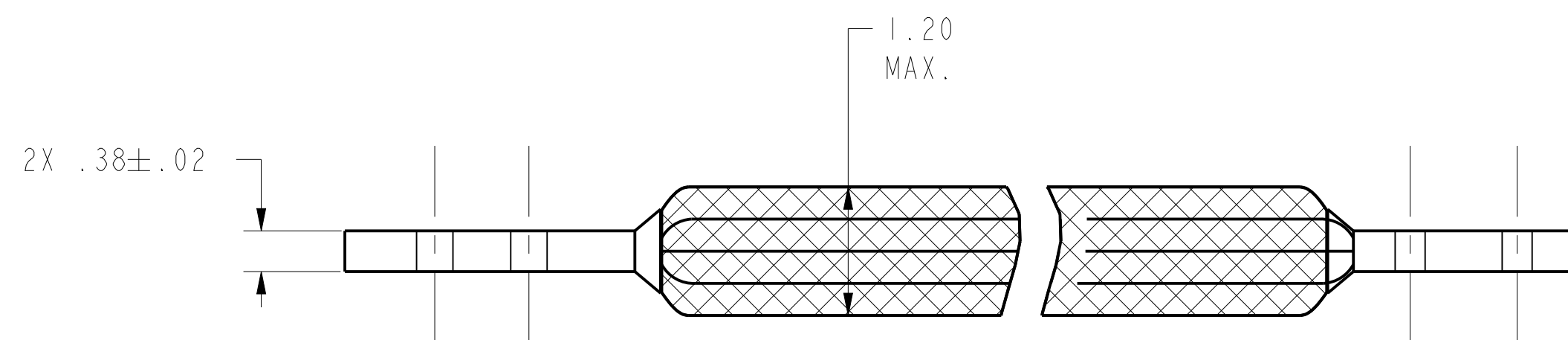

B4E51D60G41W

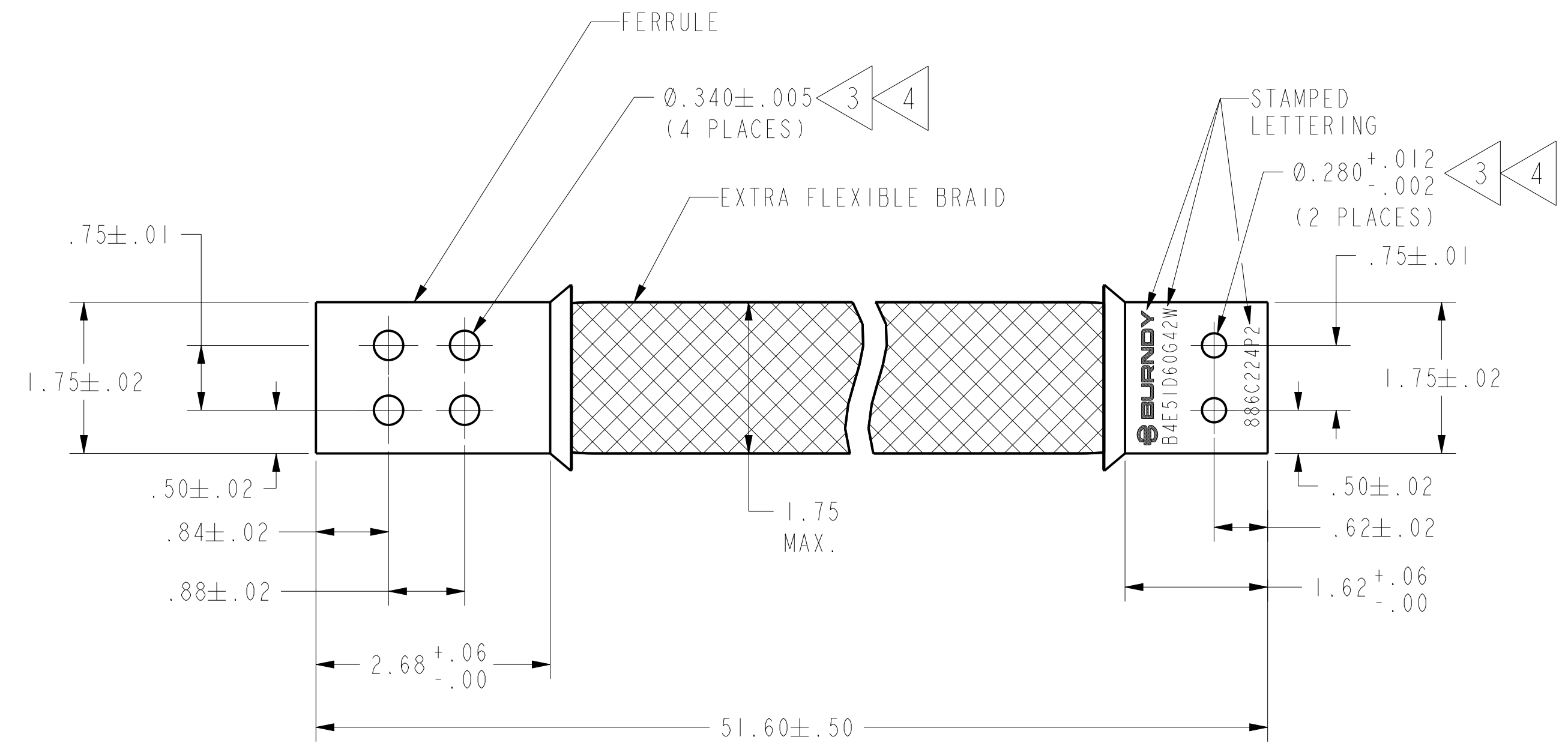
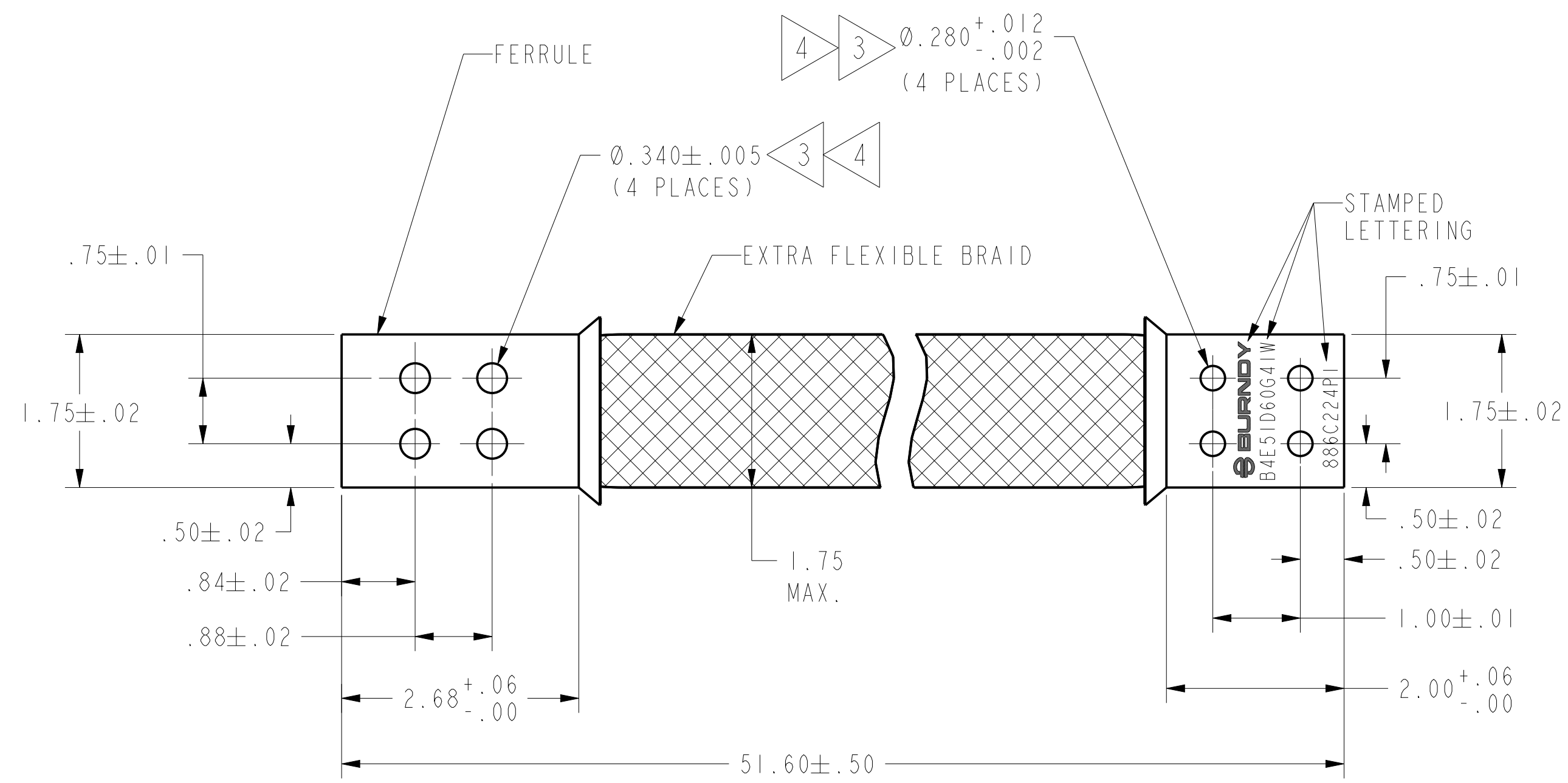
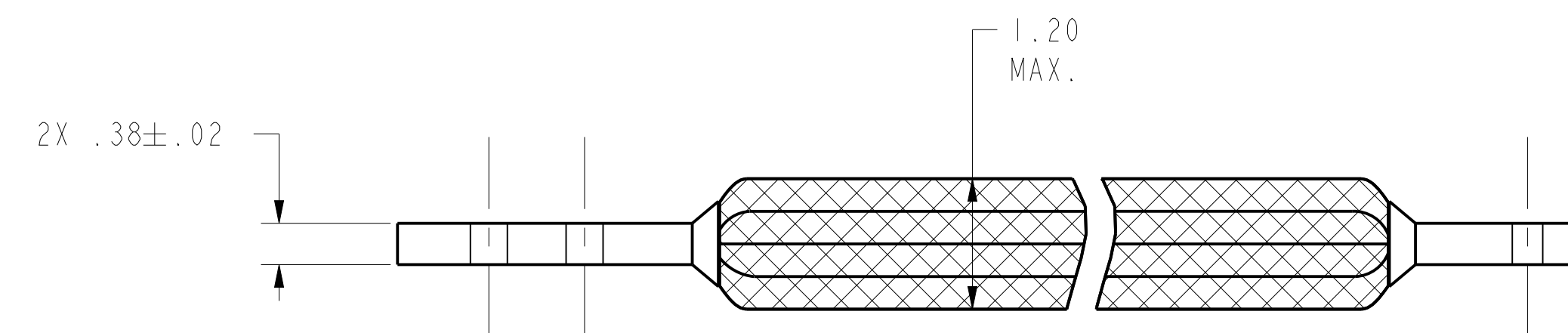

B4E51D60G42W

NOTES:

1. MATERIAL: EXTRA FLEXIBLE BRAID & FERRULES - COPPER
2. FINISH: EXTRA FLEXIBLE BRAID - ELECTRO-TIN-PLATED  
 FERRULES: HOT TIN DIPPED (.001-.004)
- 3 NO EXPOSED COPPER AFTER ASSEMBLY, INCLUDING INSIDE OF HOLES.
- 4 NO BURRS IN HOLES.
5. UNITS MUST BE BUBBLE WRAPPED AND PACKAGED IN STRAIGHT LENGTHS ONLY.

REFERENCE:

GE DWG. 886C224 & 885C970  
 SD070009, FC080814-01, FC080815-01

TO ORDER BURNDY® PRODUCTS CALL UNITED STATES 1-800-346-4175 (LONDONDERRY, NH) CANADA: 1-800-361-6975 (QUEBEC) 1-800-387-6487 (ALL OTHER PROVINCES) FOR PRODUCT INFO: <a href="http://www.burndy.com">http://www.burndy.com</a>		COPPER BRAID	
		ITEM NO: --	DRAWING NO
CAT. NO: B4E51D60G41W, B4E51D60G42W		SCALE: 1:1	
DRAWN BY: S.D.C.	08/14/73		
CHECKER: J.P.S.	08/15/73		
DSN APPVL: M.G.	08/16/73		
MFG APPVL: N/A	--		
GA APPVL: D. VARIO	12/05/95	PROJECT #: --	SIZE
MKT APPVL: C. CHADBOURNE	11/08/95	DOCUMENT TYPE: Sales	SC076149-01
PROD FAM: --		REL LEVEL: Released	D
		SHEET 1 OF 1	