

CATALOG NUMBER	ITEM NUMBER	COPPER CONDUCTOR		STUD SIZE	FIG. NO.	DIMENSIONS					INSTALLATION TOOLING (# CRIMPS)											
		SIZE	STR.			B MIN	C	L REF.	O.D.	T	DIE INFORMATION		MECHANICAL		MECHANICAL						KEARNEY DIE WH-TOOL	WIRE STRIP LENGTH
											DIE INDEX	TYPE	OUR840	MD6/MD7	Y35, Y39, Y750, PAT35, PAT750	Y46	Y45	Y48B	Y60BHU			
YCAB4W-2N	185020	#4 SOL (.204)	1	1/2"	2	1.27 [32]	1.25 [32]	5.12 [130]	.38 [10]	.25 [61]	162	DIE SET	WI62 (4)	WI62 (4)	UI62 (1)	UI62 (1)	UI62 (1)	C162 (4)	-----	-----	1-3/8"	
YCAB4C-2N	10036734	#4 STR. (.232)	7		2	1.34 [34]	1.25 [32]	5.16 [131]	.40 [10]	.25 [61]	162	DIE SET	WI62 (4)	WI62 (4)	UI62 (1)	UI62 (1)	UI62 (1)	C162 (4)	-----	-----	1-7/16"	
YCA2C-2N	10032360	#2 STR. (.291)	7		1	1.19 [30]	.99 [25]	4.83 [127]	.50 [13]	.18 [5]	163	DIE SET	WI63 (3)	WI63 (3)	UI63 (3)	UI63 (3)	UI63 (3)	C163 (2)	-----	-----	1-1/4"	
YCAB2C-2N	185117	#2 STR. (.291)	7		2	1.19 [30]	1.00 [25]	5.25 [133]	.50 [13]	.16 [4]	163	DIE SET	WI63 (3)	WI63 (3)	UI63 (3)	UI63 (3)	UI63 (3)	C163 (2)	-----	-----	1-1/4"	
YCAB2C-4N	10036732	#2 STR. (.292)	7		2	1.19 [30]	3.00 [76]	5.25 [133]	.50 [13]	.16 [4]	163	DIE SET	WI63 (3)	WI63 (3)	UI63 (3)	UI63 (3)	UI63 (3)	C163 (2)	-----	-----	1-1/4"	
YCAB1C-2N	10036691	#1 STR. (.332)	7, 19		2	1.54 [39]	1.25 [32]	5.50 [140]	.56 [14]	.25 [6]	164 OR 275	DIE SET	-----	WI64 (4)	UI64 (4)	UI64 (4)	UI64 (4)	C164 (2)	-----	-----	1-5/8"	
YCA25-2N	185090	1/0 STR. (.372)	7, 19		1	1.57 [40]	.91 [23]	5.34 [136]	.62 [16]	.19 [5]	165	DIE SET	XI65 (6)	WI65 (6)	UI65 (3)/U205 (3)	UI65 (3)/U205 (3)	UI65 (3)/U205 (3)	C165 (1)	LI65 (1)	5/8 (1)	1-5/8"	
YCAB25-4N	185106	1/0 STR. (.372)	19		2	1.57 [40]	3.00 [76]	5.75 [146]	.62 [16]	.25 [6]	165	DIE SET	XI65 (6)	WI65 (6)	UI65 (3)/U205 (3)	UI65 (3)/U205 (3)	UI65 (3)/U205 (3)	C165 (1)	LI65 (1)	-----	1-5/8"	
YCAB3K8-2N	25003726	3-#8 (.277) EXTRA HIGH STRENGTH COPPER WELD CABLE	--		2	1.49 [38]	1.00 [25]	5.53 [140]	.67 [17]	.19 [5]	205	DIE SET	XI65 (6)	WI65 (6)	UI65 (3)/U205 (3)	UI65 (3)/U205 (3)	UI65 (3)/U205 (3)	C165 (1)	LI65 (1)	-----	1-9/16"	
YCAB3K8-4N	10036733		--		2	1.49 [38]	3.00 [76]	5.39 [137]	.67 [17]	.19 [5]	205	DIE SET	XI65 (6)	WI65 (6)	UI65 (3)/U205 (3)	UI65 (3)/U205 (3)	UI65 (3)/U205 (3)	C165 (1)	LI65 (1)	-----	1-9/16"	

NOTES:

- 1 MATERIAL: [FIG.1] COPPER TUBING.
[FIG.2] TIN PLATED CAST COPPER ALLOY TONGUE WITH COPPER SLEEVE.
- 2 WHEN TONGUE OF CONNECTOR IS TO BE BOLTED TO A FLAT ALUMINIUM SURFACE ADD -W TO THE END OF THE CATALOG NUMBER. THE CONNECTOR WILL THEN BE SUPPLIED HOT TIN DIPPED. WHEN INSTALLING CONNECTOR, SCRATCH BRUSH THE ALUMINIUM SURFACE, BUT NOT THE PLATED CONNECTOR, AND APPLY PENETROX™ 'A' TO BOTH SURFACES. THESE COPPER CONNECTORS ARE NOT TO BE USED ON ALUMINIUM CABLE. SUCH AN APPLICATION WILL RESULT IN FAILURE OF ELECTRICAL JOINT.
- 3 CATALOG #PT6515 ADAPTOR IS REQUIRED TO USE "U" DIES IN Y45 SERIES TOOLS.
- 4 CATALOG #PUADP-1 ADAPTOR IS REQUIRED TO USE "U" DIES IN Y46 SERIES TOOLS.
- 5 2 CRIMPS MADE SIMULTANEOUSLY.
- 6 3 CRIMPS MADE SIMULTANEOUSLY.
- 7 4 CRIMPS MADE SIMULTANEOUSLY.
- 8 CRIMPS OVERLAP.
- 9 2 HOLES NEMA TONGUE.
- 10 OIL TIGHT CONNECTOR: WHEN OIL TIGHT CONNECTOR IS REQUIRED, ADD 'DT' TO CAT. NO. EXAMPLE: YCABIC-2NDT CONNECTOR IS TIN PLATED.
- 11 FOR CONNECTOR WITH BOTH THE TOP AND BOTTOM OF THE TONGUE FINISHED ADD THE SUFFIX "Q" TO THE CAT. NO. ALL CAT. NO. CAN BE ORDERED WITH ADDITIONAL PLATING BY ADDING THE SUFFIX, ie. TN = TIN-PLATED, SV=SILVER PLATED, AND NK=NICKEL PLATED.
- 12 DIMENSIONS IN BRACKETS [] ARE IN MILLIMETERS ROUNDED OFF TO THE NEAREST MILLIMETER, UNLESS OTHERWISE NOTED AND ARE FOR REFERENCE ONLY.
- 13 YCAB--N (FIG. 2) ASSEMBLY IS ELECTRO-TIN PLATED.
- 14 FOR FASTER INSTALLATIONS USE BURNDY PATRIOT FAMILY OF BATTERY TOOLS.

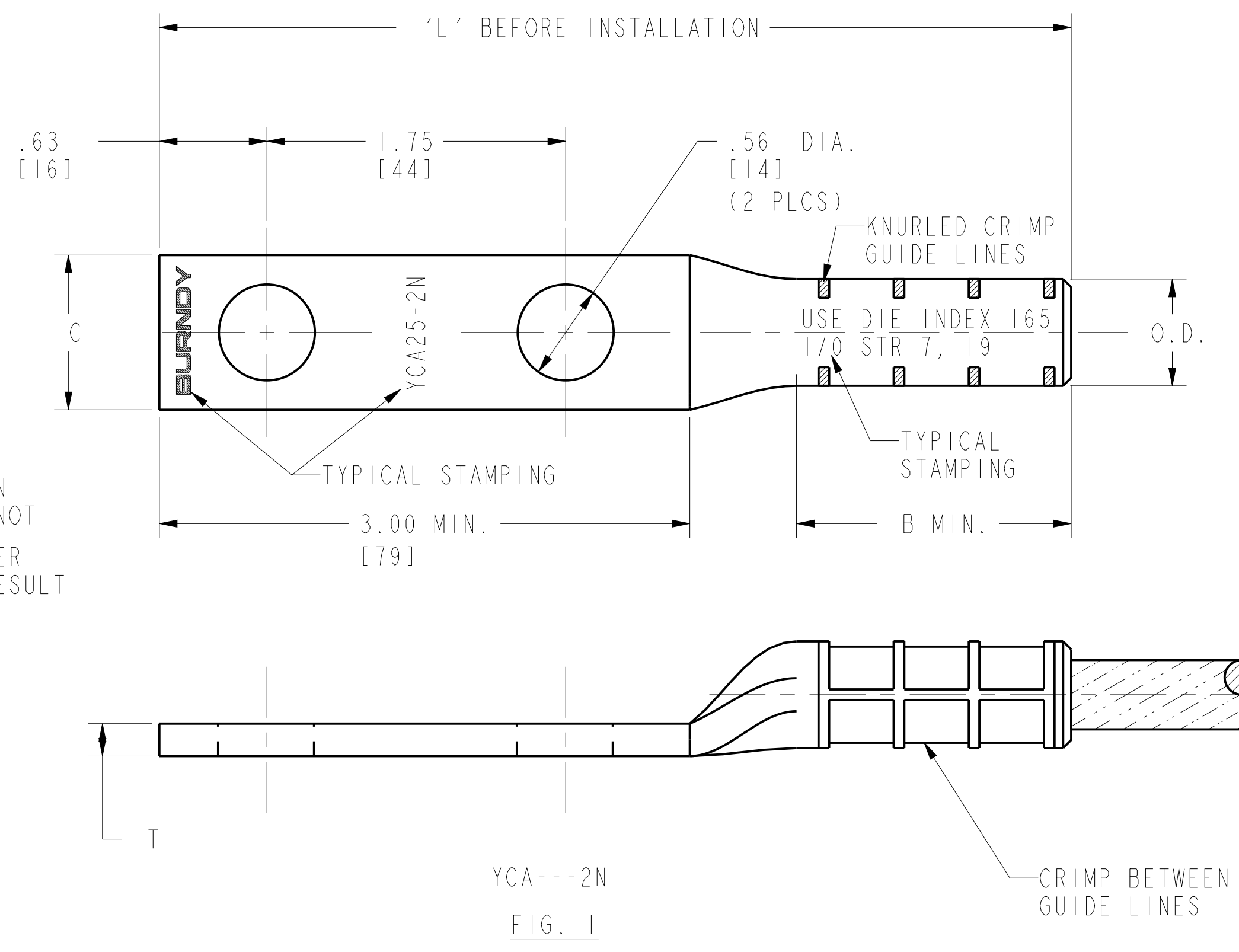

YCA---2N
FIG. 1

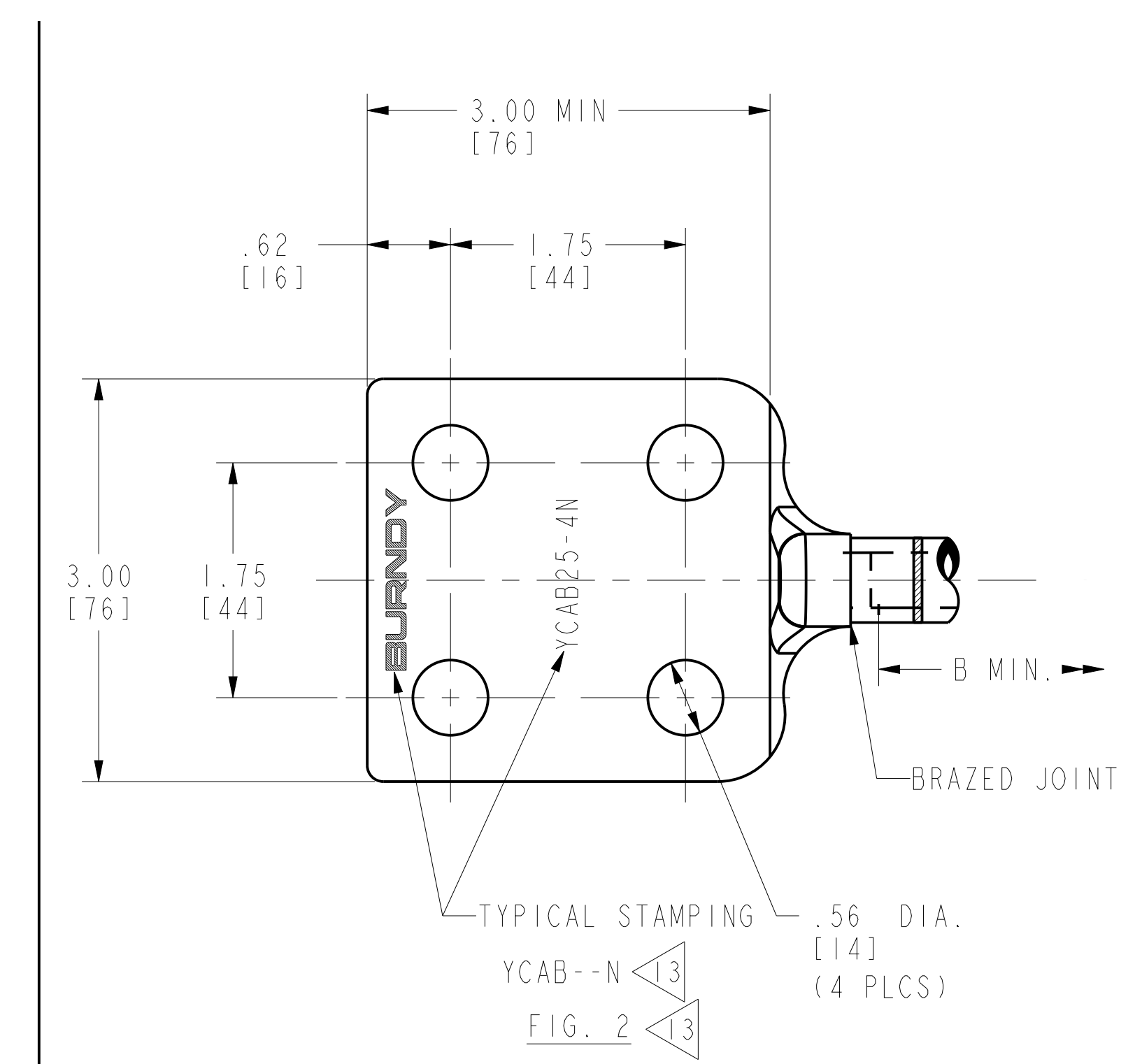

YCAB--N
FIG. 2

TO ORDER BURNDY® PRODUCTS CALL
 UNITED STATES
 1-800-346-4175 (LONDONDERRY, NH)
 CANADA:
 1-800-361-6975 (QUEBEC)
 1-800-387-6487 (ALL OTHER PROVINCES)
 FOR PRODUCT INFO: <http://www.burndy.com>

HYLUG™ (COPPER) NEMA	
ITEM NO: (TABLE)	
CAT. NO: [FIG. 1] YCA-2N, YCA-4N, YCAB-2N, YCAB-4N (TABLE)	
DRAWN BY: T.E.D.	7/12/60
CHECKER: AMC	7/12/60
DSN APPVL: MG	7/12/60
MFG APPVL: N/A	--
QA APPVL: J.BRODEUR	6/10/96
MKT APPVL: R.PELLETIER	5/13/96
PROD FAM: Overhead Bare Clamps	DRAWING NO
PROJECT #: --	SCALE: 1:1
DOCUMENT TYPE: Sales	SIZE
REL LEVEL: Released	D
	SD029071-01
	SHEET 1 OF 4

REV	DATE	DESCRIPTION	ECO	BY	C'H'K.
H	08/19/2015 00:00:00 AM	CATALOG YCA26-2N67 INCLUDED IN TABLE	41334	RW	MB

REV: PEO200

CATALOG NUMBER	COPPER CONDUCTOR		STUD SIZE	FIG. NO.	DIMENSIONS					INSTALLATION TOOLING (# CRIMPS)										
	SIZE	STR.			B MIN	C	L REF.	O.D.	T	DIE INFORMATION		MECHANICAL		HYDRAULIC					KEARNEY DIE WH-TOOL	WIRE STRIP LENGTH
										DIE INDEX	TYPE	OUR840	MD6/MD7	Y35, Y39, Y750, PAT35, PAT750	Y46	Y45	Y48B	Y60BHU		
YCA26-2N	2/0 STR. (.419)	7, 19 37	1/2"	1	1.72 [44]	.97 [25]	5.27 [134]	.71 [18]	.26 [7]	166 OR 206	DIE SET	----	WI66 (6)	U166 (3)/U459 (3)	U166 (3)/U459 (3)	U166 (3)/U459 (3)	C166 (1)	LI66 (1)	5/8 (1)	1-13/16"
YCA26-2NG7	2/0 STR. (.420)	7, 19 37		1	1.72 [44]	.97 [25]	5.30 [135]	.71 [18]	.26 [7]	166 OR 206	DIE SET	----	WI66 (6)	U166 (3)/U459 (3)	U166 (3)/U459 (3)	U166 (3)/U459 (3)	C166 (1)	LI66 (1)	5/8 (1)	1-13/16"
YCAB26-4N	2/0 STR. (.419)	7, 19 37		2	1.72 [44]	3.00 [76]	5.27 [134]	.71 [18]	.26 [7]	166 OR 206	DIE SET	----	WI66 (6)	U166 (3)/U459 (3)	U166 (3)/U459 (3)	U166 (3)/U459 (3)	C166 (1)	LI66 (1)	5/8 (1)	1-13/16"
YCA27-2N	3/0 STR. (.470)	7, 19		1	1.69 [43]	1.08 [27]	5.33 [135]	.79 [20]	.29 [7]	167, 207 OR 211	DIE SET	----	WI67 (6)	U167 (3)/U568 (3)	U167 (3)/U568 (3)	U167 (3)/U568 (3)	C167 (1)	LI67 (1)	7/8	1-3/4"
YCA78-2N	4/0 SOL. (.460)	1		1	1.50 [38]	1.13 [29]	5.12 [130]	.86 [22]	.37 [9]	168 OR 208	DIE SET	----	----	U168 (3)	U168 (3)	U168 (3)	C168 (1)	LI68 (1)	----	1-9/16"
YCA28-2N	4/0 STR. (.552)	7, 12 19		1	1.62 [41]	1.22 [31]	5.35 [136]	.89 [23]	.30 [8]	168 OR 208	DIE SET	----	----	U168 (3)	U168 (3)	U168 (3)	C168 (1)	LI68 (1)	----	1-11/16"
YCAB28-4N	4/0 STR. (.552)	7, 12 19		2	1.62 [41]	3.00 [76]	5.69 [145]	.89 [23]	.31 [8]	168 OR 208	DIE SET	----	----	U168 (3)	U168 (3)	U168 (3)	C168 (1)	LI68 (1)	----	1-11/16"
YCA29-2N	250 kcmil (.575)	7, 19 37		1	1.81 [46]	1.28 [33]	5.52 [140]	.95 [24]	.34 [9]	169	DIE SET	----	----	U169 (4)	U169 (4)	U169 (4)	C169 (1)	LI69 (1)	----	1-7/8"
YCA30-2N	300 kcmil (.630)	19, 37		1	1.71 [43]	1.42 [36]	5.54 [141]	1.05 [27]	.39 [10]	170	DIE SET	----	----	U170 (5)	U170 (5)	U170 (5)	C170 (1)	LI70 (1)	----	1-13/16"
YCAB30-4N	300 kcmil (.630)	19, 37		2	1.71 [43]	3.00 [76]	5.54 [141]	1.05 [27]	.25 [6]	170	DIE SET	----	----	U170 (5)	U170 (5)	U170 (5)	C170 (1)	LI70 (1)	----	1-13/16"

NOTES:

- 1 MATERIAL: [FIG.1] COPPER TUBING.
[FIG.2] TIN PLATED CAST COPPER ALLOY TONGUE WITH COPPER SLEEVE.
- 2 WHEN TONGUE OF CONNECTOR IS TO BE BOLTED TO A FLAT ALUMINIUM SURFACE ADD -W TO THE END OF THE CATALOG NUMBER. THE CONNECTOR WILL THEN BE SUPPLIED HOT TIN DIPPED. WHEN INSTALLING CONNECTOR, SCRATCH BRUSH THE ALUMINIUM SURFACE, BUT NOT THE PLATED CONNECTOR, AND APPLY PENETROX™ 'A' TO BOTH SURFACES. THESE COPPER CONNECTORS ARE NOT TO BE USED ON ALUMINIUM CABLE. SUCH AN APPLICATION WILL RESULT IN FAILURE OF ELECTRICAL JOINT.
- 3 CATALOG #PT6515 ADAPTOR IS REQUIRED TO USE "U" DIES IN Y45 SERIES TOOLS.
- 4 CATALOG #PUADP-1 ADAPTOR IS REQUIRED TO USE "U" DIES IN Y46 SERIES TOOLS.
- 5 2 CRIMPS MADE SIMULTANEOUSLY.
- 6 3 CRIMPS MADE SIMULTANEOUSLY.
- 7 4 CRIMPS MADE SIMULTANEOUSLY.
- 8 CRIMPS OVERLAP.
- 9 2 HOLES NEMA TONGUE.
- 10 OIL TIGHT CONNECTOR: WHEN OIL TIGHT CONNECTOR IS REQUIRED, ADD 'DT' TO CAT. NO. EXAMPLE: YCABIC-2NDT CONNECTOR IS TIN PLATED.
- 11 FOR CONNECTOR WITH BOTH THE TOP AND BOTTOM OF THE TONGUE FINISHED ADD THE SUFFIX "Q" TO THE CAT. NO. ALL CAT. NO. CAN BE ORDERED WITH ADDITIONAL PLATING BY ADDING THE SUFFIX, ie. TN = TIN-PLATED, SV=SILVER PLATED, AND NK=NICKEL PLATED.
- 12 DIMENSIONS IN BRACKETS [] ARE IN MILLIMETERS ROUNDED OFF TO THE NEAREST MILLIMETER, UNLESS OTHERWISE NOTED AND ARE FOR REFERENCE ONLY.
- 13 YCAB--N (FIG. 2) ASSEMBLY IS ELECTRO-TIN PLATED.
- 14 FOR FASTER INSTALLATIONS USE BURNDY PATRIOT FAMILY OF BATTERY TOOLS.

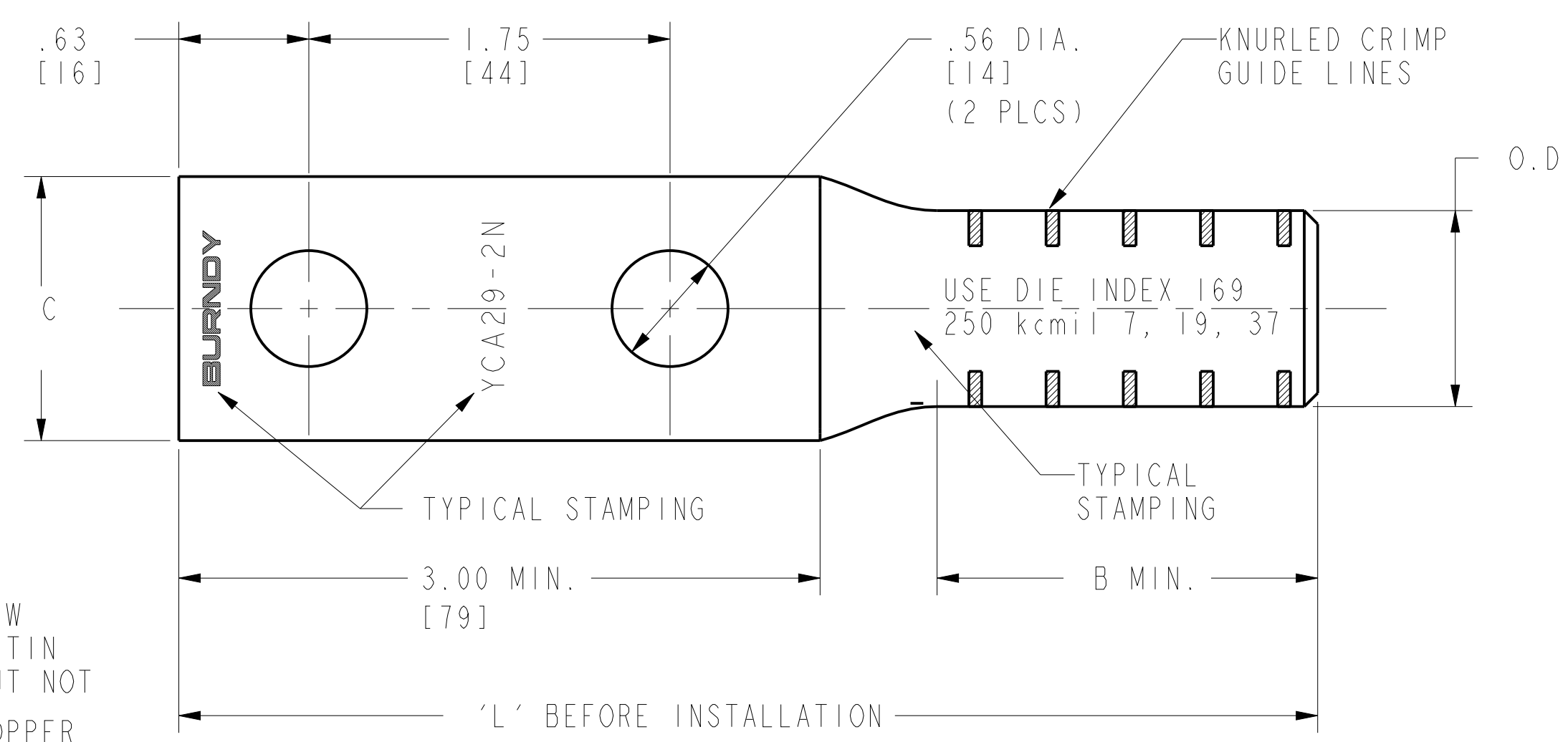

YCA---2N
FIG. 1
CRIMP BETWEEN GUIDE LINES

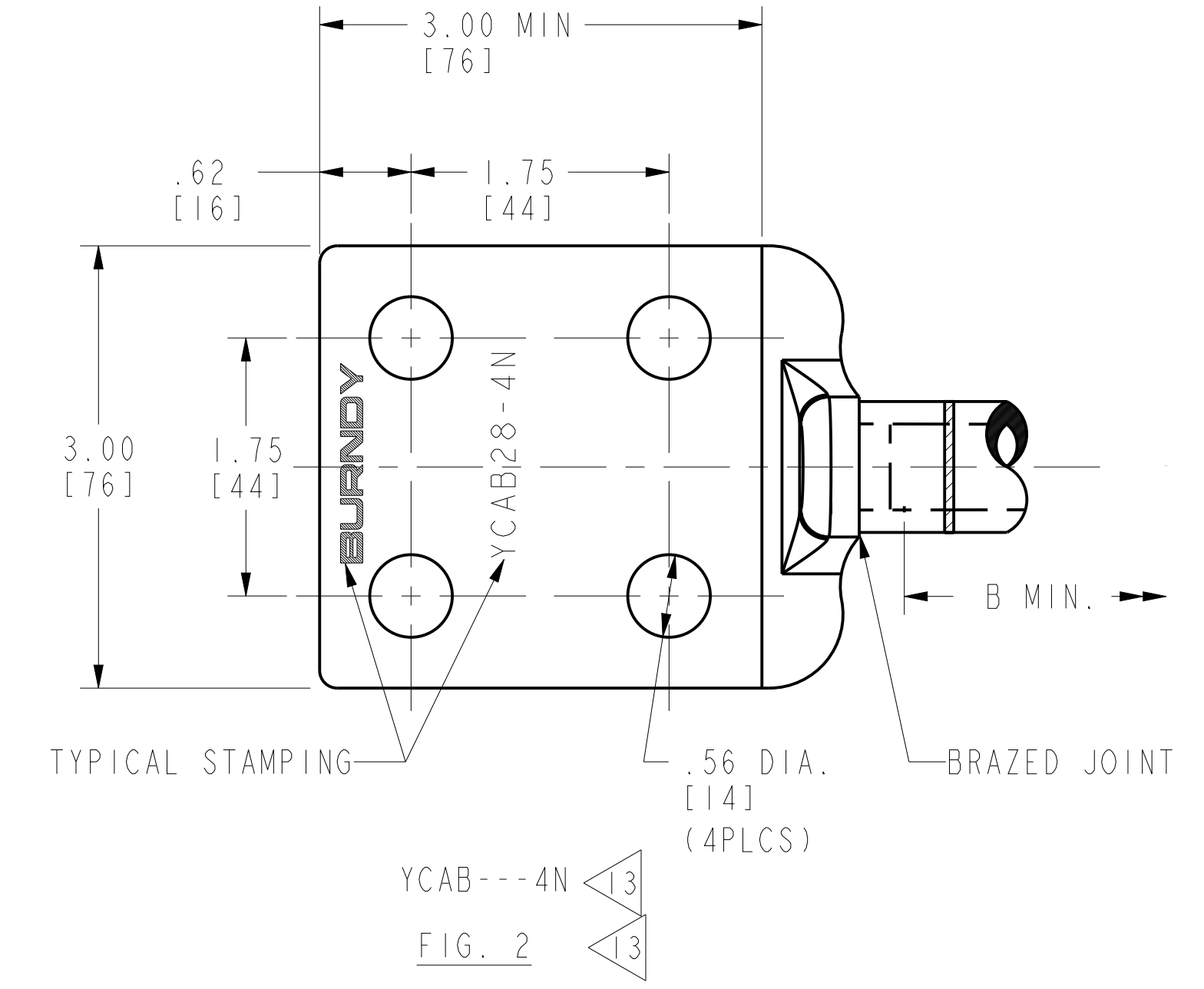

YCAB---4N
FIG. 2

TO ORDER BURNDY® PRODUCTS CALL		HYLUG™ (COPPER) NEMA	
UNITED STATES 1-800-346-4175 (LONDONDERRY, NH)		ITEM NO: N/A	CAT. NO: YCA-- (TABLE)
CANADA: 1-800-361-6975 (QUEBEC) 1-800-387-6487 (ALL OTHER PROVINCES)		DRAWN BY: T.E.D. 11/04/64	CHECKER: AMC 11/05/64
FOR PRODUCT INFO: http://www.burndy.com		DSN APPVL: MG 11/06/64	MFG APPVL: N/A
		GA APPVL: J.BRODEUR 6/10/96	MKT APPVL: R.PELLETTIER 5/13/96
		PROD FAM: Overhead_Bare_Clamps	DRAWING NO: SD029071-01
		PROJECT #: --	SCALE: 1:1
		DOCUMENT TYPE: Sales	REV: H
		REL LEVEL: Released	SHEET 2 OF 4

REV	DATE	DESCRIPTION	ECO	BY	C'H'K.
H	08/19/2015 00:00:00 AM	CATALOG YCA26-2NG7 INCLUDED IN TABLE	41334	RW	MB

REV: PEO200

CATALOG NUMBER	COPPER CONDUCTOR		STUD SIZE	FIG. NO.	DIMENSIONS					INSTALLATION TOOLING (# CRIMPS)										
					B MIN	C	L REF.	O.D.	T	DIE INFORMATION		MECHANICAL RATCHET		HYDRAULIC				KEARNEY DIE WH-TOOL	WIRE STRIP LENGTH	
										DIE INDEX	TYPE	OUR840	MD6/MD7	Y35, Y39, Y750, PAT35, PAT750	Y46	Y45	Y48B			Y60BHU
YCA31-2N	350 kcmil (.710)	12, 19 37	1/2"	1	2.66 [68]	1.63 [41]	6.55 [166]	1.17 [30]	.43 [11]	267	DIE SET	----	----	U267 (6)	U267 (6)	U267 (6)	C267 (2)	L267 (2)	----	2-3/4"
YCA31-4N	350 kcmil (.710)	12, 19 37		2	2.66 [68]	3.00 [76]	7.00 [178]	1.17 [30]	.38 [10]	267	DIE SET	----	----	U267 (6)	U267 (6)	U267 (6)	C267 (2)	L267 (2)	----	2-3/4"
YCA32-2N	400 kcmil (.728)	19, 37		1	2.78 [71]	1.67 [42]	6.72 [171]	1.24 [31]	.48 [12]	209	DIE SET	----	----	U209 (6)	U209 (6)	U209 (6)	C209 (2)	L209 (2)	----	2-7/8"
YCA32-4N	400 kcmil (.728)	19, 37		2	2.78 [71]	3.00 [76]	7.12 [181]	1.24 [31]	.25 [6]	209	DIE SET	----	----	U209 (6)	U209 (6)	U209 (6)	C209 (2)	L209 (2)	----	2-7/8"
YCA33-2N	450 kcmil (.772)	37		1	2.78 [71]	1.67 [42]	6.72 [171]	1.24 [31]	.48 [12]	209	DIE SET	----	----	U209 (6)	U209 (6)	U209 (6)	C209 (2)	L209 (2)	----	2-7/8"
YCA33-4N	450 kcmil (.772)	37		2	2.78 [71]	3.00 [76]	6.82 [173]	1.24 [31]	.19 [5]	209	DIE SET	----	----	U209 (6)	U209 (6)	U209 (6)	C209 (2)	L209 (2)	----	2-7/8"
YCA34-2N	500 kcmil (.814)	19, 37		1	2.53 [64]	1.88 [48]	6.52 [166]	1.38 [35]	.51 [13]	210	DIE SET	----	----	U210 (6)	U210 (6)	U210 (6)	C210 (2)	L210 (2)	----	2-5/8"
YCA34-4N	500 kcmil (.814)	19, 37		2	2.53 [64]	3.00 [76]	6.81 [173]	1.38 [35]	.38 [10]	210	DIE SET	----	----	U210 (6)	U210 (6)	U210 (6)	C210 (2)	L210 (2)	----	2-5/8"

NOTES:

- 1 MATERIAL: [FIG.1] COPPER TUBING.
[FIG.2] TIN PLATED CAST COPPER ALLOY TONGUE WITH COPPER SLEEVE.
- 2 WHEN TONGUE OF CONNECTOR IS TO BE BOLTED TO A FLAT ALUMINIUM SURFACE ADD -W TO THE END OF THE CATALOG NUMBER. THE CONNECTOR WILL THEN BE SUPPLIED HOT TIN DIPPED. WHEN INSTALLING CONNECTOR, SCRATCH BRUSH THE ALUMINIUM SURFACE, BUT NOT THE PLATED CONNECTOR, AND APPLY PENETROX™ 'A' TO BOTH SURFACES. THESE COPPER CONNECTORS ARE NOT TO BE USED ON ALUMINIUM CABLE. SUCH AN APPLICATION WILL RESULT IN FAILURE OF ELECTRICAL JOINT.
- 3 CATALOG #PT6515 ADAPTOR IS REQUIRED TO USE "U" DIES IN Y45 SERIES TOOLS.
- 4 CATALOG #PUADP-1 ADAPTOR IS REQUIRED TO USE "U" DIES IN Y46 SERIES TOOLS.
- 5 2 CRIMPS MADE SIMULTANEOUSLY.
- 6 3 CRIMPS MADE SIMULTANEOUSLY.
- 7 4 CRIMPS MADE SIMULTANEOUSLY.
- 8 CRIMPS OVERLAP.
- 9 2 HOLES NEMA TONGUE.
- 10 OIL TIGHT CONNECTOR: WHEN OIL TIGHT CONNECTOR IS REQUIRED, ADD 'DT' TO CAT. NO. EXAMPLE: YCABIC-2NDT CONNECTOR IS TIN PLATED.
- 11 FOR CONNECTOR WITH BOTH THE TOP AND BOTTOM OF THE TONGUE FINISHED ADD THE SUFFIX "Q" TO THE CAT. NO. ALL CAT. NO. CAN BE ORDERED WITH ADDITIONAL PLATING BY ADDING THE SUFFIX, ie. TN = TIN-PLATED, SV=SILVER PLATED, AND NK=NICKEL PLATED.
- 12 DIMENSIONS IN BRACKETS [] ARE IN MILLIMETERS ROUNDED OFF TO THE NEAREST MILLIMETER, UNLESS OTHERWISE NOTED AND ARE FOR REFERENCE ONLY.
- 13 YCAB--N (FIG. 2) ASSEMBLY IS ELECTRO-TIN PLATED.
- 14 FOR FASTER INSTALLATIONS USE BURNDY PATRIOT FAMILY OF BATTERY TOOLS.

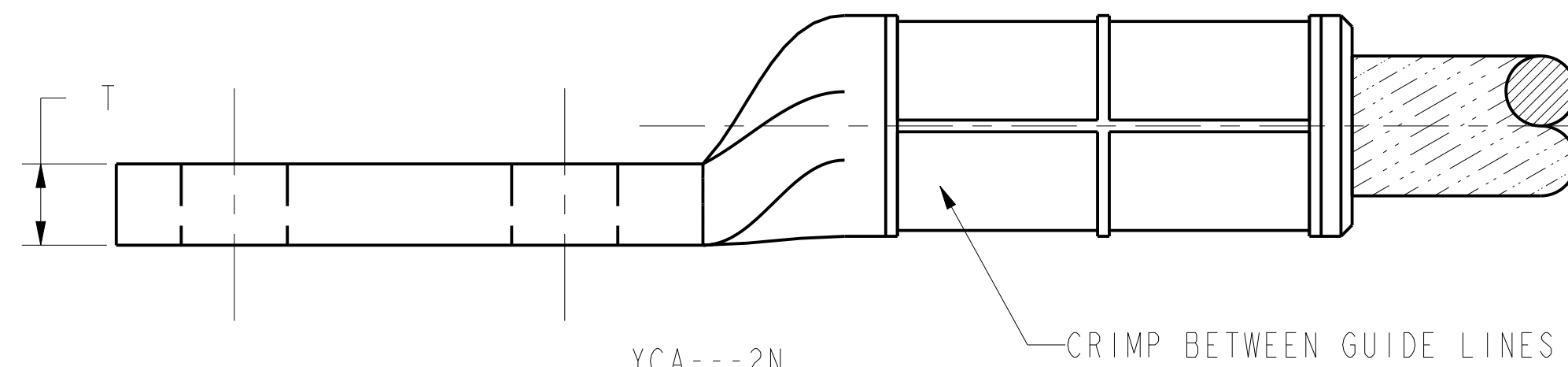
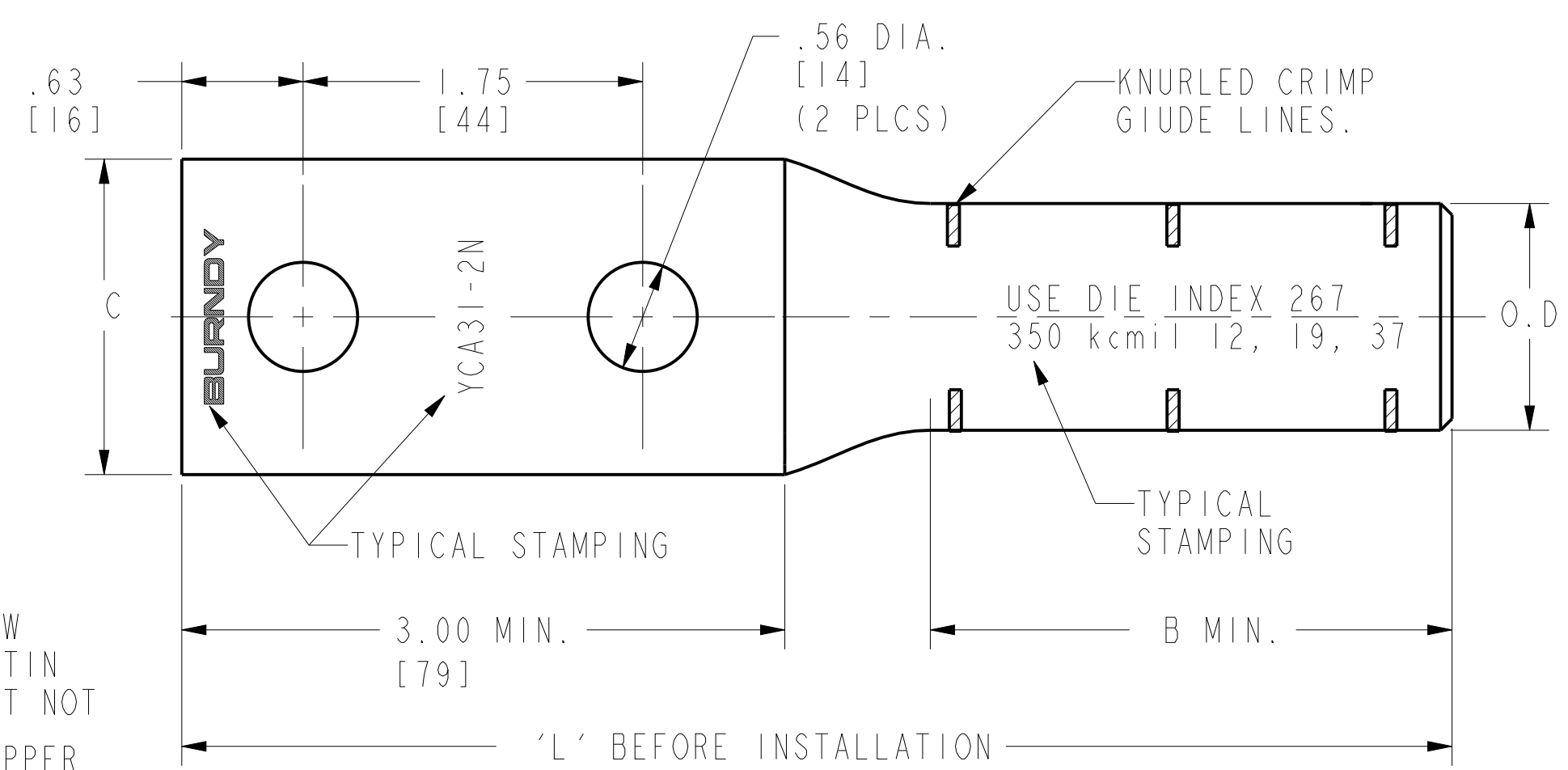

YCA---2N
FIG. 1

YCAB---4N
FIG. 2

REV: PEC200

REV	DATE	DESCRIPTION	ECO	BY	C'H'K.
H	08/19/2015 00:00:00 AM	CATALOG YCA26-2N67 INCLUDED IN TABLE	41334	RW	MB

TO ORDER BURNDY® PRODUCTS CALL		HYLUG™ (COPPER) NEMA	
UNITED STATES 1-800-346-4175 (LONDONDERRY, NH)		ITEM NO: --	
CANADA: 1-800-361-6975 (QUEBEC) 1-800-387-6487 (ALL OTHER PROVINCES)		CAT. NO: YCA-2N, YCA--NW, YCA--NDT, YCAB-2N, YCAB-4N (TABLE)	
FOR PRODUCT INFO: http://www.burndy.com		DRAWN BY: J. AYER 07/16/96	
		CHECKER: J. MICHAUD 07/18/96	
		DSN APPVL: A. BRAZEAU 04/17/96	
		MFG APPVL: N/A --	
		GA APPVL: J. BRODEUR 06/10/96	
		MKT APPVL: R. PELLETIER 05/13/96	
		PROD FAM: Overhead_Bare_Clamps	
		DRAWING NO	
		PROJECT #: --	
		SCALE: 1:1	
		DOCUMENT TYPE: Sales	
		SIZE	
		REL LEVEL: Released	
		SD029071-01	
		SHEET 3 OF 4	
		H	

CATALOG NUMBER	COPPER CONDUCTOR		STUD SIZE	FIG. NO.	DIMENSIONS					INSTALLATION TOOLING (# CRIMPS)										
					B MIN	C	L REF.	O.D.	T	DIE INFORMATION		MECHANICAL RATCHET		HYDRAULIC					KEARNEY DIE WH-TOOL	WIRE STRIP LENGTH
										DIE INDEX	TYPE	OUR840	MD6/MD7	Y35, Y39, Y750, PAT35, PAT750	Y46	Y45	Y48B	Y60BHU		
YCA36-2N	600 kcmil (.893)	37, 61	1/2"	1	2.19 [56]	2.10 [53]	6.30 [160]	1.55 [39]	.58 [15]	576	DIE SET	----	----	----	----	----	C576 (2)	L576 (2)	----	2-1/4"
YCAB36-4N	600 kcmil (.893)	37, 61		2	2.19 [56]	3.00 [76]	6.59 [167]	1.55 [39]	.50 [13]	576	DIE SET	----	----	----	----	----	C576 (2)	L576 (2)	----	2-1/4"
YCA39-2N	750 kcmil (.998)	37, 61		1	3.00 [76]	2.31 [59]	7.22 [183]	1.70 [43]	.64 [16]	627	DIE SET	----	----	----	----	----	C627 (3)	L627 (2)	----	3-1/16"
YCAB39-4N	750 kcmil (.998)	37, 61		2	3.00 [76]	3.00 [76]	8.53 [217]	1.70 [43]	.50 [13]	627	DIE SET	----	----	----	----	----	C627 (3)	L627 (2)	----	3-1/16"
YCAB40-4NW	800 kcmil (1.031)	37, 61		2	3.00 [76]	3.00 [76]	8.53 [217]	1.70 [43]	.50 [13]	627	DIE SET	----	----	----	----	----	C627 (3)	L627 (2)	----	3-1/16"
YCA44-2N	1000 kcmil (1.152)	61		1	3.29 [84]	2.71 [69]	8.04 [204]	2.00 [51]	.73 [19]	345	DIE SET	----	----	----	----	----	C345 (4)	L345 (4)	----	3-3/8"
YCAB44-2N	1000 kcmil (1.152)	61		2	3.31 [84]	2.00 [51]	7.80 [198]	2.00 [51]	.50 [13]	345	DIE SET	----	----	----	----	----	C345 (4)	L345 (4)	----	3-3/8"
YCAB44-4N	1000 kcmil (1.152)	61		2	3.31 [84]	3.00 [76]	7.80 [198]	2.00 [51]	.62 [16]	345	DIE SET	----	----	----	----	----	C345 (4)	L345 (4)	----	3-3/8"
YCAB47-4N	1750 kcmil (1.526)	91, 127		2	3.38 [86]	3.00 [76]	7.93 [201]	1.98 [50]	.50 [13]	----	DIE SET	----	----	----	----	----	C47R (3)	----	----	3-7/16"
YCA44-4N	1000 kcmil (1.152)	61		1 & 2	3.29 [84]	3.00 [76]	8.14 [207]	2.00 [51]	.71 [18]	345	DIE SET	----	----	----	----	----	C345 (4)	L345 (4)	----	3-3/8"
YCA45-2N	1250 kcmil (1.284)	61		1	3.29 [84]	2.71 [69]	8.04 [204]	2.00 [51]	.73 [19]	345	DIE SET	----	----	----	----	----	C345 (4)	L345 (4)	----	3-3/8"
YCA44A - 2NG2	1000 kcmil (1.152)	61		1	3.29 [84]	2.71 [69]	11 [280]	2.00 [51]	.625 [16]	345	DIE SET	----	----	----	----	----	C345 (4)	L345 (4)	----	3-3/8"

NOTES:

- MATERIAL: [FIG.1] COPPER TUBING. [FIG.2] TIN PLATED CAST COPPER ALLOY TONGUE WITH COPPER SLEEVE.
- WHEN TONGUE OF CONNECTOR IS TO BE BOLTED TO A FLAT ALUMINIUM SURFACE ADD -W TO THE END OF THE CATALOG NUMBER. THE CONNECTOR WILL THEN BE SUPPLIED HOT TIN DIPPED. WHEN INSTALLING CONNECTOR, SCRATCH BRUSH THE ALUMINIUM SURFACE, BUT NOT THE PLATED CONNECTOR, AND APPLY PENETROX™ 'A' TO BOTH SURFACES. THESE COPPER CONNECTORS ARE NOT TO BE USED ON ALUMINIUM CABLE. SUCH AN APPLICATION WILL RESULT IN FAILURE OF ELECTRICAL JOINT.
- CATALOG #PT6515 ADAPTOR IS REQUIRED TO USE "U" DIES IN Y45 SERIES TOOLS.
- CATALOG #PUADP-1 ADAPTOR IS REQUIRED TO USE "U" DIES IN Y46 SERIES TOOLS.
- 2 CRIMPS MADE SIMULTANEOUSLY.
- 3 CRIMPS MADE SIMULTANEOUSLY.
- 4 CRIMPS MADE SIMULTANEOUSLY.
- CRIMPS OVERLAP.
- 2 HOLES NEMA TONGUE.
- OIL TIGHT CONNECTOR: WHEN OIL TIGHT CONNECTOR IS REQUIRED, ADD 'DT' TO CAT. NO. EXAMPLE: YCABIC-2NDT CONNECTOR IS TIN PLATED.
- FOR CONNECTOR WITH BOTH THE TOP AND BOTTOM OF THE TONGUE FINISHED ADD THE SUFFIX "O" TO THE CAT. NO. ALL CAT. NO. CAN BE ORDERED WITH ADDITIONAL PLATING BY ADDING THE SUFFIX, ie. TN = TIN-PLATED, SV=SILVER PLATED, AND NK=NICKEL PLATED.
- DIMENSIONS IN BRACKETS [] ARE IN MILLIMETERS ROUNDED OFF TO THE NEAREST MILLIMETER, UNLESS OTHERWISE NOTED AND ARE FOR REFERENCE ONLY.
- YCAB--N (FIG. 2) ASSEMBLY IS ELECTRO-TIN PLATED.
- FOR FASTER INSTALLATIONS USE BURNDY PATRIOT FAMILY OF BATTERY TOOLS.
- YCA44-4N IS MADE FROM TUBING AS SHOWN IN FIG. 1, BUT HAS A 4 HOLE NEMA HOLE PATTERN SIMILAR TO FIG. 2.

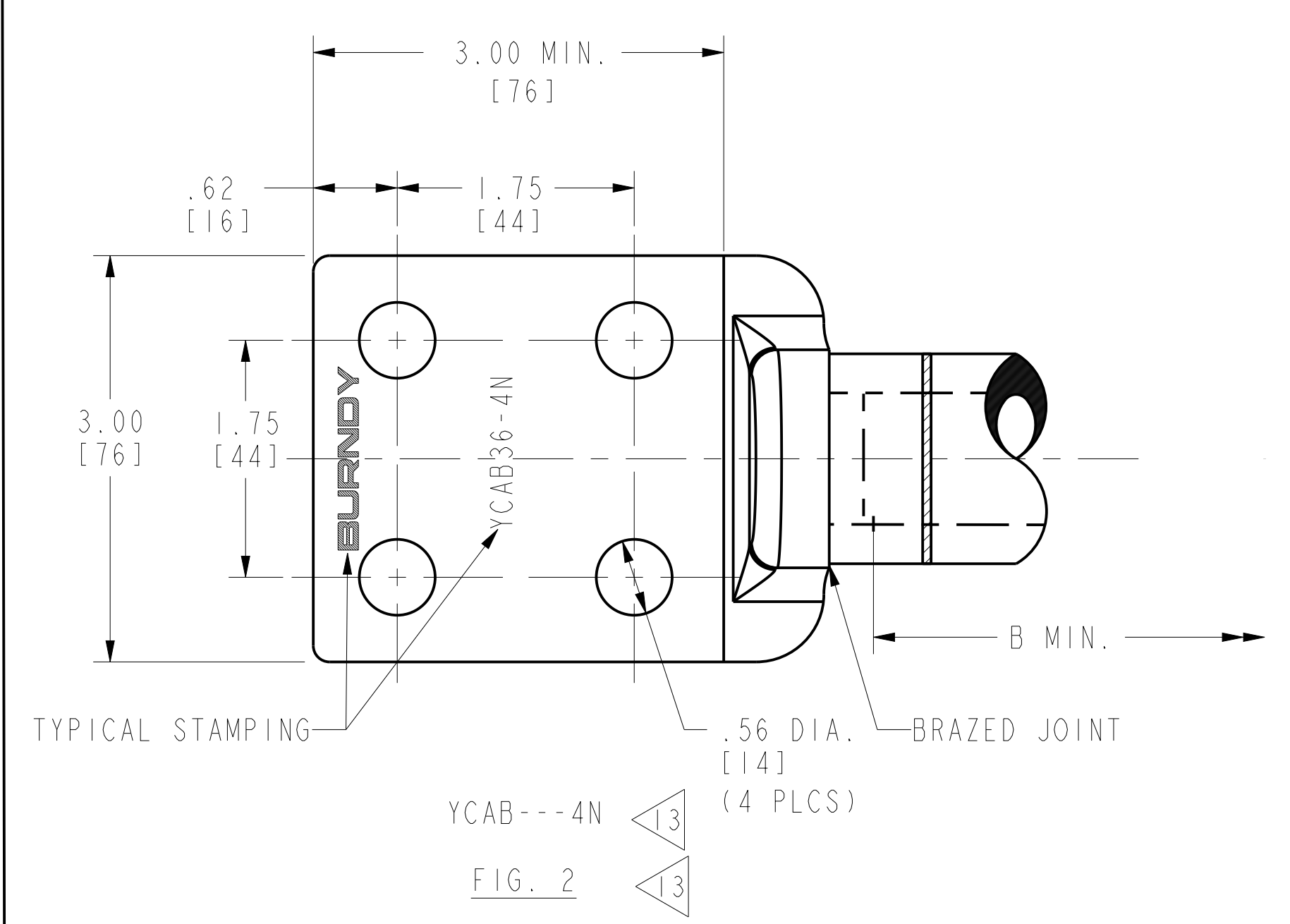
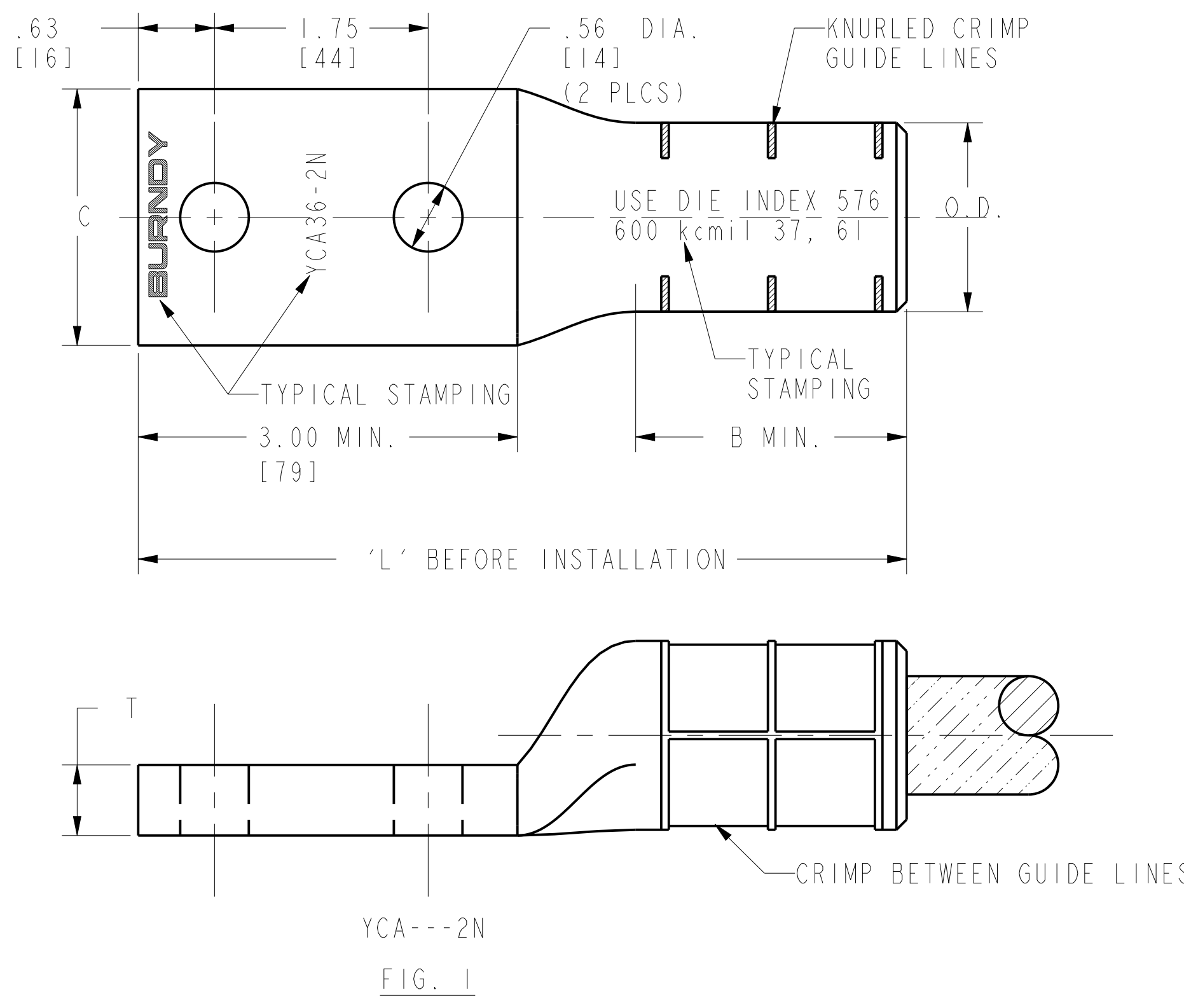

TO ORDER BURNDY® PRODUCTS CALL
 UNITED STATES
 1-800-346-4175 (LONDONDERRY, NH)
 CANADA:
 1-800-361-6975 (QUEBEC)
 1-800-387-6487 (ALL OTHER PROVINCES)
 FOR PRODUCT INFO: <http://www.burndy.com>

HYLUG™ (COPPER) NEMA	
ITEM NO: --	SCALE: 1:1
CAT. NO: YCA--, YCAB-- (TABLE)	DRAWING NO: SD029071-01
DRAWN BY: J. AYER 07/17/96	REV: H
CHECKER: J. MICHAUD 07/18/96	
DSN APPVL: A. BRAZEAU 04/17/96	
MFG APPVL: N/A	
QA APPVL: J. BRODEUR 05/13/96	
MKT APPVL: R. PELLETIER 05/13/96	
PROD FAM: Overhead_Bare_Clamps	
PROJECT #: --	
DOCUMENT TYPE: Sales	
REL LEVEL: Released	

REV	DATE	DESCRIPTION	ECO	BY	C'H'K.
H	08/19/2015 00:00:00 AM	CATALOG YCA26-2NG7 INCLUDED IN TABLE	41334	RW	MB

REV: PEO200