

REV	DATE	DESCRIPTION	ECO	BY	C'H'K.
C	04/17/2012 00:00:00 AM	MTG HARDWARE NOTE CHANGED TO TABLE FORMAT	27186	VV	NJS

CATALOG NO.	ALUM. I.P.S	BOLT CIRCLE	A DIA.	B	G	H	J	K	L	W	X DIA.
UHG13A3	1/2"	3.00 [76]	.840 [21]	1.38 [35]	1.75 [44]	3.09 [78]	1/2"-13	.56 [14]	7.44 [189]	2.66 [68]	4.25 [108]
UHG14A3	3/4"	3.00 [76]	1.050 [27]	1.38 [35]	2.00 [51]	3.50 [83]	1/2"-13	.56 [14]	7.44 [189]	2.94 [75]	4.25 [108]
UHG14A5	3/4"	5.00 [127]	1.050 [27]	1.38 [35]	2.25 [57]	4.00 [102]	1/2"-13	.69 [18]	9.82 [249]	2.94 [75]	6.25 [159]
UHG15A3	1"	3.00 [76]	1.315 [33]	1.38 [35]	2.00 [51]	3.88 [99]	1/2"-13	.56 [14]	7.44 [189]	3.06 [78]	4.25 [108]
UHG15A5	1"	5.00 [127]	1.315 [33]	1.38 [35]	2.25 [57]	3.82 [97]	1/2"-13	.69 [18]	9.82 [242]	3.19 [81]	6.25 [159]
UHG16A3	1-1/4"	3.00 [76]	1.660 [42]	1.50 [38]	2.25 [57]	3.79 [96]	1/2"-13	.56 [14]	7.68 [195]	3.50 [89]	4.25 [108]
UHG16A5	1-1/4"	5.00 [127]	1.660 [42]	1.50 [38]	2.38 [60]	3.94 [100]	1/2"-13	.69 [18]	10.06 [256]	3.50 [89]	6.25 [159]
UHG17A3	1-1/2"	3.00 [76]	1.900 [48]	1.50 [38]	2.50 [64]	4.06 [103]	1/2"-13	.56 [14]	7.68 [195]	3.66 [93]	4.25 [108]
UHG17A5	1-1/2"	5.00 [127]	1.900 [48]	1.50 [38]	2.50 [64]	4.06 [103]	1/2"-13	.69 [18]	10.06 [256]	3.66 [93]	6.25 [159]
UHG17A7	1-1/2"	7.00 [178]	1.900 [48]	1.50 [38]	2.50 [64]	4.06 [103]	1/2"-13	.81 [21]	12.75 [324]	3.66 [93]	8.50 [216]
UHG18A3	2"	3.00 [76]	2.375 [60]	1.50 [38]	2.75 [70]	5.25 [133]	1/2"-13	.56 [14]	7.68 [195]	4.12 [105]	4.25 [108]
UHG18A5	2"	5.00 [127]	2.375 [60]	1.50 [38]	2.75 [70]	4.61 [117]	1/2"-13	.69 [18]	10.06 [256]	4.12 [105]	6.25 [159]
UHG19A3	2-1/2"	3.00 [76]	2.875 [73]	1.50 [38]	3.12 [79]	5.23 [133]	1/2"-13	.56 [14]	7.68 [195]	4.62 [117]	4.25 [108]
UHG19A5	2-1/2"	5.00 [127]	2.875 [73]	1.50 [38]	3.12 [79]	5.23 [133]	1/2"-13	.69 [18]	10.56 [256]	4.62 [117]	6.25 [159]
UHG20A3	3"	3.00 [76]	3.500 [89]	1.75 [44]	3.62 [92]	6.09 [155]	5/8"-11	.56 [14]	9.25 [235]	5.62 [143]	4.25 [108]
UHG20A5	3"	5.00 [127]	3.500 [89]	1.75 [44]	3.62 [92]	6.09 [155]	5/8"-11	.69 [18]	10.56 [268]	5.62 [143]	6.25 [159]
UHG21A3	3-1/2"	3.00 [76]	4.00 [102]	1.75 [44]	4.00 [102]	6.74 [171]	5/8"-11	.56 [14]	8.18 [208]	6.16 [156]	4.25 [108]
UHG21A5	3-1/2"	5.00 [127]	4.00 [102]	1.75 [44]	4.00 [102]	6.74 [171]	5/8"-11	.69 [18]	10.56 [268]	6.16 [156]	6.25 [159]
UHG22A3	4"	3.00 [76]	4.500 [114]	1.75 [44]	4.500 [114]	7.50 [191]	5/8"-11	.56 [14]	8.18 [208]	6.62 [168]	4.25 [108]
UHG22A5	4"	5.00 [127]	4.500 [114]	1.75 [44]	4.500 [114]	7.50 [191]	5/8"-11	.69 [18]	11.34 [288]	6.62 [168]	6.25 [159]
UHG23A3	4-1/2"	3.00 [76]	5.00 [127]	1.75 [44]	4.75 [121]	8.38 [213]	5/8"-11	.56 [14]	9.25 [235]	7.14 [181]	4.25 [108]
UHG23A5	4-1/2"	5.00 [127]	5.00 [127]	1.75 [44]	4.75 [121]	7.94 [202]	5/8"-11	.69 [18]	10.56 [268]	7.14 [181]	6.25 [159]
UHG24A3	5"	3.00 [76]	5.563 [141]	2.00 [51]	5.25 [133]	8.86 [225]	5/8"-11	.56 [14]	8.68 [220]	7.70 [196]	4.25 [108]
UHG24A5	5"	5.00 [127]	5.563 [141]	2.00 [51]	5.25 [133]	8.86 [225]	5/8"-11	.69 [18]	11.56 [294]	7.70 [196]	6.25 [159]
UHG86A3	6"	3.00 [76]	6.625 [168]	2.00 [51]	5.56 [141]	9.94 [252]	5/8"-11	.56 [14]	9.25 [235]	8.75 [222]	4.25 [108]
UHG86A5	6"	5.00 [127]	6.623 [168]	2.00 [51]	5.56 [141]	9.94 [252]	5/8"-11	.69 [18]	11.56 [294]	8.75 [222]	6.25 [159]
UHG88A3	8"	3.00 [76]	8.625 [219]	2.00 [51]	--	--	5/8"-11	.56 [14]	--	10.75 [273]	4.25 [108]
UHG88A5	8"	5.00 [127]	8.625 [219]	2.00 [51]	--	--	5/8"-11	.69 [18]	--	10.75 [273]	6.25 [159]

NOTES:

- MATERIAL: CAST ALUMINUM ALLOY
- DIMENSIONS IN BRACKETS [ ] DENOTES METRIC UNITS [SI UNITS] AND ARE ROUNDED TO THE NEAREST WHOLE NUMBER. UNLESS OTHERWISE SPECIFIED THESE UNITS SHALL BE USED FOR REFERENCE ONLY.
- OPTIONAL HARDWARE VARIATIONS ARE AVAILABLE BY ADDING THE FOLLOWING SUFFIX TO THE CATALOG NUMBER.  
EXAMPLE: UHG24A5SS  
GS = GALVANIZED STEEL  
SS = STAINLESS STEEL
- NOMINAL INSTALLATION TORQUE:  
1/2" ALUMINUM BOLTS - 300 LB-IN [35 NM]  
1/2" GALVANIZED STEEL BOLTS - 480 LB-IN [55 NM]  
1/2" STAINLESS STEEL BOLTS - 480 LB-IN [55 NM]  
5/8" ALUMINUM BOLTS - 480 LB-IN [55 NM]  
5/8" GALVANIZED STEEL BOLTS - 660 LB-IN [75 NM]  
5/8" STAINLESS STEEL BOLTS - 660 LB-IN [75 NM]

GALVANIZED STL HARDWARE KITS	3" DIA. BOLT CIRCLES		5" DIA. BOLT CIRCLES		7" DIA BOLT CIRCLES	
	CAP MTG.	BASE MTG.	CAP MTG.	BASE MTG.	CAP MTG.	BASE MTG.
BOLTS	1/2-13X1.00	1/2-13X1.50	5/8-11X1.25	5/8-11X1.75	3/4-10X1.25	3/4-10X2.00
SPLIT LW	1/2	1/2	5/8	5/8	3/4	3/4
FLAT WASHER	1/2	1/2	5/8	5/8	3/4	3/4
HEX NUT	NONE	1/2-13	NONE	5/8-11	NONE	3/4-10
QTY EACH	4	4	4	4	4	4

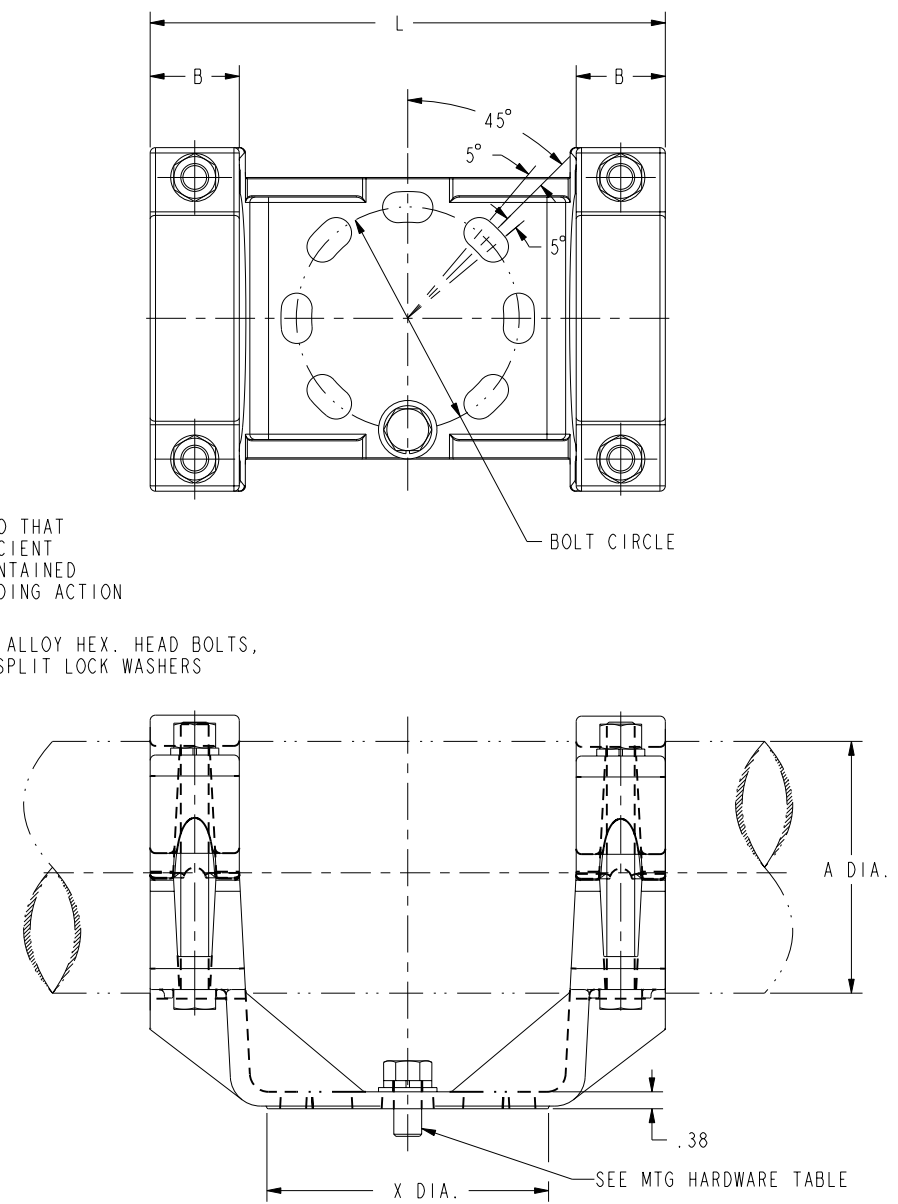
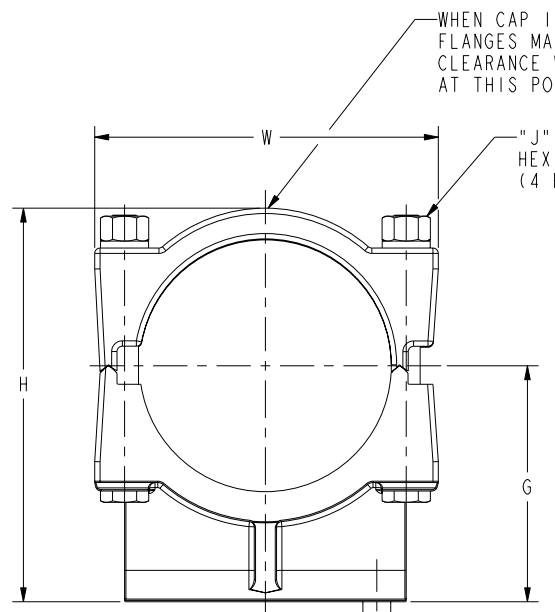

TO ORDER BURNDY® PRODUCTS CALL  
UNITED STATES  
1-800-346-4175 (LONDONDERRY, NH)  
CANADA:  
1-800-361-6975 (QUEBEC)  
1-800-387-6487 (ALL OTHER PROVINCES)  
FOR PRODUCT INFO: <http://www.burndy.com>

ALUMINUM BUS SUPPORT CLAMP	
ITEM NO:	--
CAT. NO:	UHG--A- (SEE TABLE)
DRAWN BY:	BAKKIYARAJ K 11/11/10
CHECKER:	J HOSKER 11/16/10
DSN APPVL:	R LAVOIE 04/21/12
MFG APPVL:	--
QA APPVL:	J HILLMAN 04/25/12
MKT APPVL:	V TORRES 04/21/12
PROD FAM:	SUBSTATION
PROJECT #:	--
DOCUMENT TYPE:	Sales
REL LEVEL:	Released
DRAWING NO	SD040887-01
SCALE:	1:1
REV	C
SHEET	1 OF 1