

DRAWING NO.
SD055917

7

6

5

4

3

2

1

REV	DATE	DESCRIPTION	ECO	BY	C'H'K.
G	06/25/2014 11:22:00 AM	UPDATE SALE DRAWING PER MARKUP	36566	AD	BSB

CATALOG NUMBER		CONDUCTORS ACCOMMODATED				J	P	B	CFy	Wy	HI	LI	QI	CFx	Wx	H2	L2	Q2	NUT TORQUE	STUD TORQUE
FIG. 1	FIG. 2	AWG.		METRIC WIRE SIZE		REF.	±.02	MIN EFF THD.	±.02	REF.	±.03	±.03	±.03	±.02	REF.	±.03	±.03	±.03	LBS*IN [N*M]	LBS*IN [N*M]
		STRANDED	SOLID	STRANDED	SOLID															
KC15	K2C15	12 (.092 DIA)	12 (.081 DIA)	[4mm ² (2.6 DIA)]	[4mm ² (2.3 DIA)]	1/4-20 UNC-2A	.14 [3.6]	.37 [9.4]	.38 [9.7]	.44 [11.2]	.69 [17.5]	1.19 [30.2]	.53 [13.5]	.50 [12.7]	.56 [14.2]	.81 [20.6]	1.31 [33.3]	.66 [16.8]	80 [9.0]	80 [9.0]
KC15B1	K2C15B1	9 (.130 DIA)	8 (.128 DIA)	[6mm ² (3.2 DIA)]	[6mm ² (2.8 DIA)]			.87 [22.1]				1.69 [42.9]				1.81 [46.0]				
KC17	K2C17	10 (.116 DIA)	10 (.102 DIA)	[6mm ² (3.2 DIA)]	[6mm ² (2.8 DIA)]	1/4-20 UNC-2A	.17 [4.2]	.37 [9.4]	.44 [11.2]	.50 [12.7]	.84 [21.3]	1.34 [34.0]	.66 [16.8]	.62 [15.7]	.69 [17.5]	1.00 [25.4]	1.50 [38.1]	.81 [20.6]	80 [9.0]	80 [9.0]
KC17B1	K2C17B1	7 (.164 DIA)	6 (.162 DIA)	[10mm ² (4.1 DIA)]	[10mm ² (3.6 DIA)]			.87 [22.1]				1.84 [46.7]				2.00 [50.8]				
KC20	K2C20	10 (.116 DIA)	10 (.102 DIA)	[6mm ² (3.2 DIA)]	-----	5/16-18 UNC-2A	.22 [5.5]	.41 [10.4]	.50 [12.7]	.58 [14.7]	.86 [21.8]	1.42 [36.1]	.70 [17.8]	.69 [17.5]	.78 [19.8]	1.06 [26.9]	1.62 [41.1]	.91 [23.1]	165 [18.6]	180 [20.3]
KC20B1	K2C20B1	5 (.206 DIA)	4 (.204 DIA)	[16mm ² (5.1 DIA)]	-----			.85 [21.6]				1.92 [48.8]				2.06 [52.3]				
KC22	K2C22	10 (.116 DIA)	10 (.102 DIA)	[6mm ² (3.2 DIA)]	-----	3/8-16 UNC-2A	.26 [6.7]	.46 [11.7]	.62 [15.7]	.72 [18.3]	1.00 [25.4]	1.62 [41.1]	.81 [20.6]	.75 [19.1]	.84 [21.3]	1.25 [31.8]	1.88 [47.8]	1.06 [26.9]	275 [31.1]	280 [31.6]
KC22B1	K2C22B1	3 (.260 DIA)	2 (.258 DIA)	[25mm ² (6.5 DIA)]	-----			.96 [24.4]				2.12 [53.8]				2.38 [60.5]				
KC23	K2C23	8 (.146 DIA)	10 (.102 DIA)	[10mm ² (4.1 DIA)]	-----	3/8-16 UNC-2A	.32 [8.2]	.46 [11.7]	.62 [15.7]	.72 [18.3]	1.05 [26.7]	1.67 [42.4]	.86 [21.8]	.81 [20.6]	.94 [23.9]	1.34 [34.0]	1.97 [50.0]	1.16 [29.5]	275 [31.1]	280 [31.6]
KC23B1	K2C23B1	2 (.292 DIA)	1 (.289 DIA)	[35mm ² (6.5 DIA)]	-----			.97 [24.6]				2.19 [55.6]				2.47 [62.7]				
KC23-BDT	-	8 (.146 DIA)	10 (.102 DIA)	[10mm ² (4.1 DIA)]	-----	5/16-18 UNC-2A	.32 [8.2]	.44 [11.2]	.62 [15.7]	.72 [18.3]	1.05 [26.7]	1.49 [37.8]	.86 [21.8]	.81 [20.6]	.94 [23.9]	---	---	---	275 [31.1]	180 [20.3]
KC25	K2C25	2 (.292 DIA)	2 (.258 DIA)	[35mm ² (6.5 DIA)]	-----	1/2-13 UNC-2A	.39 [9.8]	.53 [13.5]	.75 [19.1]	.88 [22.4]	1.19 [30.2]	1.94 [49.3]	1.00 [25.4]	.93 [23.6]	1.15 [29.2]	1.56 [39.6]	2.31 [58.7]	1.38 [35.1]	385 [43.5]	480 [54.2]
KC25B1	K2C25B1	1/0 (.373 DIA)	2/0 (.365 DIA)	[50mm ² (9.3 DIA)]	-----			1.04 [26.4]				2.44 [62.0]				2.81 [71.4]				
FIG. 3	FIG. 4					REF	±.05		±.03	REF	±.05	±.05	±.05	±.03	REF	±.05	±.05	±.05		
KC26	K2C26	2 (.292 DIA)	2 (.258 DIA)	[35mm ² (6.5 DIA)]	-----	1/2-13 UNC-2A	.44 [11.0]	.52 [13.2]	.88 [22.4]	1.01 [25.7]	1.38 [35.1]	2.12 [53.8]	1.16 [29.5]	1.04 [26.4]	1.28 [32.5]	1.81 [46.0]	2.53 [64.3]	1.56 [39.6]	385 [43.5]	480 [54.2]
KC26B1	K2C26B1	2/0 (.419 DIA)	3/0 (.410 DIA)	[70mm ² (9.3 DIA)]	-----			1.04 [26.4]				2.62 [66.5]				3.09 [78.5]				
KC28	K2C28	1 (.332 DIA)	1 (.289 DIA)	[50mm ² (9.3 DIA)]	-----	5/8-11 UNC-2A	.55 [14.0]	.75 [19.1]	1.18 [30.0]	1.00 [25.4]	1.94 [49.3]	2.95 [74.9]	1.67 [42.4]	1.35 [34.3]	1.56 [39.6]	2.46 [62.5]	3.44 [87.4]	2.20 [55.9]	500 [56.5]	660 [74.6]
KC28B1	K2C28B1	4/0 (.528 DIA)	4/0 (.460 DIA)	[95mm ² (12.8 DIA)]	-----			1.25 [31.8]				3.45 [87.6]				3.94 [100.1]				
KC31	K2C31	1 (.332 DIA)	-----	[50mm ² (9.3 DIA)]	-----	5/8-11 UNC-2A	.70 [17.8]	.75 [19.1]	1.43 [36.3]	1.29 [32.8]	2.19 [55.6]	3.19 [81.0]	1.84 [46.7]	1.69 [42.9]	1.91 [48.5]	2.88 [73.2]	3.88 [98.6]	2.53 [64.3]	650 [73.4]	660 [74.6]
KC31B1	K2C31B1	350 Kcmil (.681 DIA)	-----	[150mm ² (16.0 DIA)]	-----			1.23 [31.2]				3.69 [93.7]				4.38 [111.3]				
KC34	K2C34	3/0 (.470 DIA)	-----	[95mm ² (12.8 DIA)]	-----	3/4-10 UNC-2A	.85 [21.5]	.99 [25.1]	1.62 [41.1]	1.45 [36.8]	2.38 [60.5]	3.62 [91.9]	1.97 [50.0]	2.00 [50.8]	2.28 [57.9]	31.9 [81.0]	4.44 [112.8]	2.78 [70.6]	825 [93.2]	1050 [118.7]
KC34B1	K2C34B1	500 Kcmil (.813 DIA)	-----	[240mm ² (20.3 DIA)]	-----			1.49 [37.8]				4.12 [104.6]				4.94 [125.5]				
KC39	K2C39	350 Kcmil (.681 DIA)	-----	[185mm ² (17.8 DIA)]	-----	7/8-9 UNC-2A	1.01 [25.7]	1.13 [25.4]	1.88 [47.8]	1.92 [48.8]	2.94 [74.7]	4.32 [109.7]	2.53 [64.3]	2.31 [58.7]	2.62 [66.5]	3.94 [100.1]	5.32 [135.1]	3.53 [89.7]	1000 [113.0]	1700 [192.1]
KC39B1	K2C39B1	750 Kcmil (.998 DIA)	-----	[300mm ² (22.6 DIA)]	-----			1.63 [41.4]				4.82 [122.4]				5.82 [147.8]				
KC44	K2C44	500 Kcmil (.813 DIA)	-----	[300mm ² (22.6 DIA)]	-----	1-8 UNC-2A	1.17 [29.6]	1.19 [30.2]	2.12 [53.8]	2.12 [53.8]	3.23 [82.0]	4.73 [120.1]	2.83 [71.9]	2.56 [65.0]	2.91 [73.9]	4.39 [111.5]	5.89 [149.6]	3.99 [101.3]	1100 [124.3]	2550 [288.2]
KC44B1	K2C44B1	1000 Kcmil (1.152 DIA)	-----	[500mm ² (28.3 DIA)]	-----			1.69 [42.9]				5.23 [132.8]				6.42 [163.1]				

REV: PE0200

TO ORDER BURNDY® PRODUCTS CALL		SERVIT POST™ (MALE)	
UNITED STATES		ITEM NO: N/A	
1-800-346-4175 (LONDONDERRY, NH)		CAT. NO: KC--, K2C-- (TABLE)	
CANADA:		DRAWN BY: A.J.M. 4/16/94	
1-800-361-6975 (QUEBEC)		CHECKER: L.S.T. 4/25/94	
1-800-387-6487 (ALL OTHER PROVINCES)		DSN APPVL: C.PALAGI 4/94	
FOR PRODUCT INFO: http://www.burndy.com		MFG APPVL: --	
		QA APPVL: A.LLOYD 4/94	
		MKT APPVL: P.WERTHMAN 4/94	
		PROJ #: --	SCALE: 1:000
		PROJECT #: --	DRAWING NO
		DOCUMENT TYPE: Sales	SD055917
		REL LEVEL: Released	SHEET 1 OF 2
			REV
			G

8

7

6

5

4

3

2

1

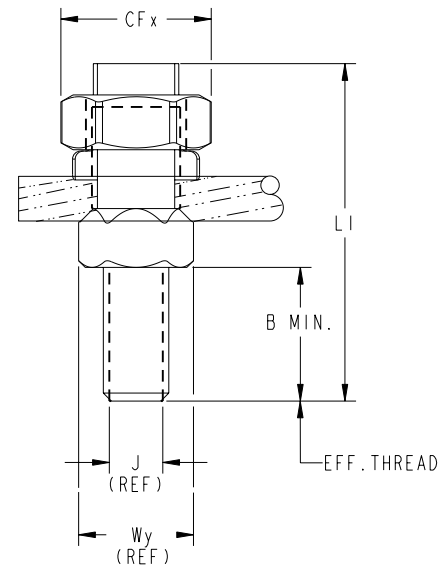

FIG. 1

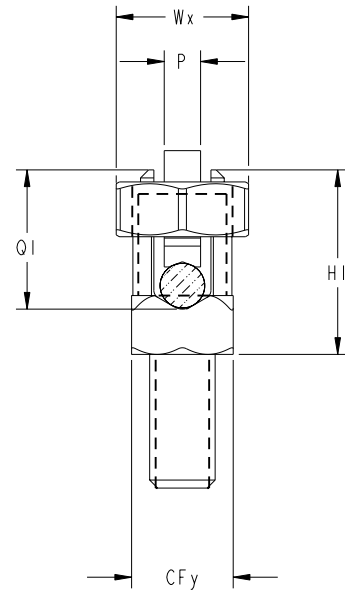

FIG. 2

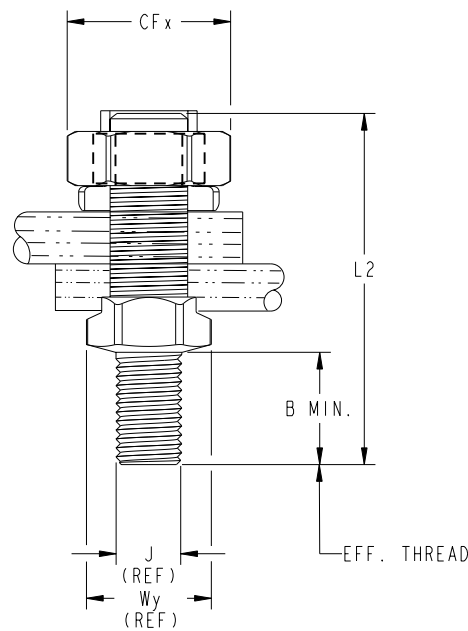

FIG. 3

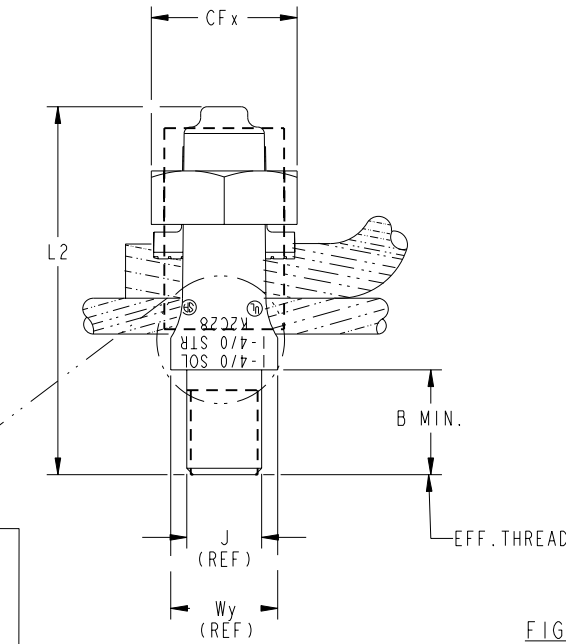
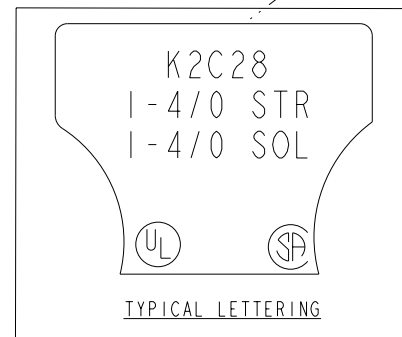
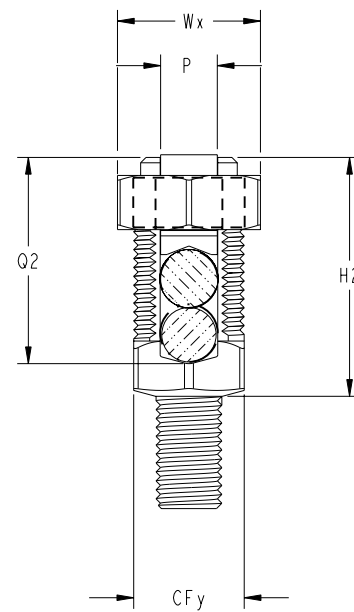

FIG. 5

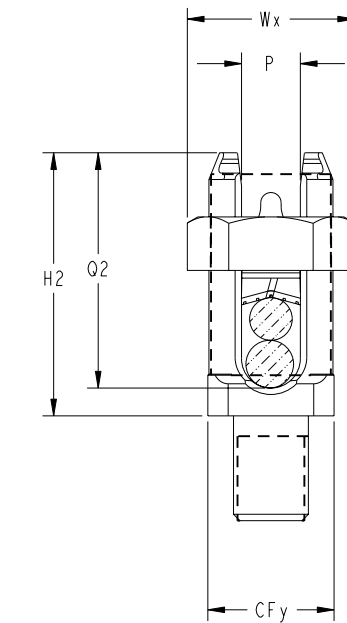

FIG. 6

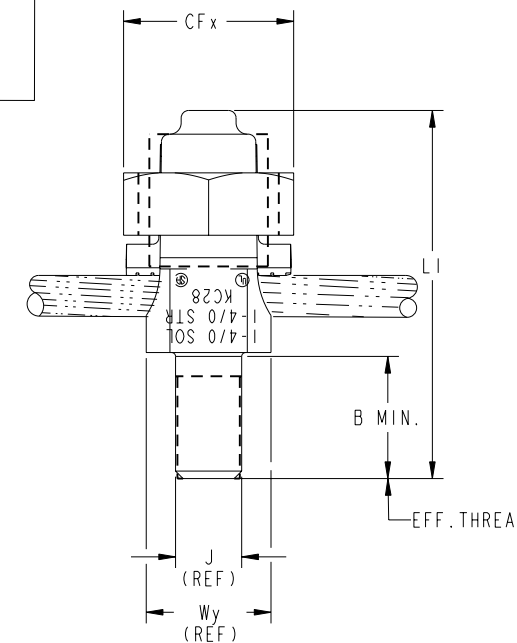
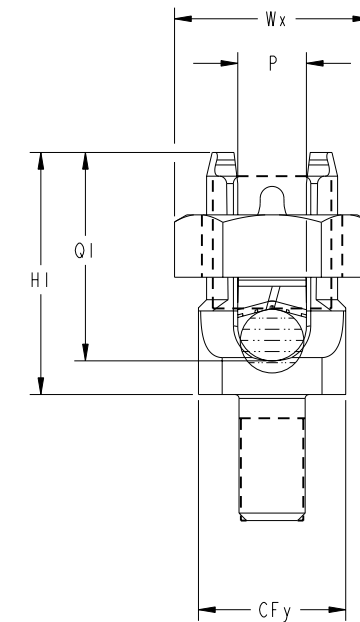

FIG. 7



NOTES:

- MATERIAL: LEADED COMMERCIAL BRONZE (KC15-KC26).
CAST COPPER ALLOY (KC28-KC44).
- FINISH: NONE. ADD SUFFIX "TN" FOR TIN PLATING,
ADD SUFFIX "NK" FOR NICKEL PLATING.
- ALL ITEMS ARE LISTED TO UL 467, FILE E9999 AND CSA C22.2
NO. 65, FILE 42861, UNLESS OTHERWISE NOTED.
- DIMENSIONS IN [] BRACKETS ARE IN MILLIMETERS ROUNDED OFF
TO THE NEAREST TENTH OF A MILLIMETER, UNLESS OTHERWISE
NOTED AND ARE FOR REFERENCE ONLY.
- THESE ITEMS ARE NOT UL467 LISTED. KC34 & K2C34 SERIES UL467
LISTED FOR CONDUCTOR SIZES UP TO 300.
- CATALOG NUMBER KC34J12T13 IS THE SAME AS THE KC34, EXCEPT
THE KC34J12T13 HAS A 1/2-13 UNC-2A (J REF.) THREAD.

REV: PE0200

TO ORDER BURNDY® PRODUCTS CALL		SERVIT POST™ (MALE)	
UNITED STATES		ITEM NO: N/A	
1-800-346-4175 (LONDONDERRY, NH)		CAT. NO: KC--, K2C-- (TABLE)	
CANADA:		DRAWN BY: A.J.M. 4/16/94	
1-800-361-6975 (QUEBEC)		CHECKER: L.S.T. 4/25/94	
1-800-387-6487 (ALL OTHER PROVINCES)		DSN APPVL: C.PALAGI 4/94	
FOR PRODUCT INFO: http://www.burndy.com		MFG APPVL: --	
		QA APPVL: A.LLOYD 4/94	
		MKT APPVL: P.WERTHMAN 4/94	
		PROJ #: --	SCALE: 1:000
		DOCUMENT TYPE: Sales	DRAWING NO: SD055917
		REL LEVEL: Released	REV: G
		SIZE: D	SHEET 2 OF 2