

DRAWING NO.  
SD079848

REV	DATE	DESCRIPTION	ECO	BY	C'H'K.
C	05/19/2014 00:00:00 AM	NOTE ADDED AS PER ECO WARRIP	36169	AD	BSB

CATALOG NUMBER	STRANDED COPPER CONDUCTOR ACCOMMODATED			BOLT SIZE	METRIC BOLT SIZE	DIMENSIONS							
	CODE (AWG)	NAVY	METRIC SIZE (CLASS 2)			B	C	K DIA	L	N	O.D.	T REF.	Z MIN.
YA39L	750 Kcmil	↑ ↓	375mm <sup>2</sup> STR	5/8	M16	1.42 [36]	1.91 [49]	.69 [18]	3.57 [93]	.66 [17]	1.30 [33]	.27 [7]	.67 [17]
YA39L2				7/8	----	↑	↑	.94 [24]	4.10 [104]	.88 [22]	↑	↑	.89 [23]
YA39L9				1-1/4	----	↓	↓	1.31 [33]	4.85 [123]	1.25 [32]	↓	↓	1.27 [32]
YA39L6				1/2	M12	1.42 [36]	1.91 [49]	.53 [13]	3.41 [87]	.53 [13]	1.30 [33]	.27 [7]	.55 [14]
YA40L	800 Kcmil		400mm <sup>2</sup> STR [26.1]	5/8	M16	1.42 [36]	1.98 [50]	.69 [18]	3.81 [97]	.66 [17]	1.35 [34]	.30 [8]	.67 [17]
YA41L	850 Kcmil		----	5/8	M16	1.88 [48]	2.01 [51]	.69 [18]	4.15 [105]	.66 [17]	1.38 [8]	.31 [8]	.67 [17]

CONNECTOR SIZE	TOLERANCES					
	B	C	K DIA.	L	N	O.D.
-8C THRU -25	±.06	±.04	±.02	±.09	±.03	±.01
-26 THRU -34	±.08	±.04	±.02	±.12	±.03	±.01
-35 AND UP	±.09	±.06	±.02	±.15	±.06	±.01

TOLERANCE BLOCK

INSTALLATION TOOLING (# CRIMPS)

CATALOG NO.	COLOR CODE	DIE INFORMATION		MECHANICAL RATCHET				HYDRAULIC						DIELESS (# CRIMPS)	WIRE STRIP LENGTH	
		DIE INDEX	TYPE	YIMRTC 5	OUR840	MD6 MD7	MD6--R2 MD7-34R	Y500CT PATMD6 PAT600	Y34A Y34B Y34BH 7	Y35, Y39 Y750, BAT35 PAT750	Y46 PAT46 4	Y45 3	Y48B			Y60BHU
YA39L YA39L2 YA39L9 YA39L6	BLACK	24	BLACK DIE SET NEST INDENTOR	----	----	----	----	----	----	U39RT(2)	U39RT(2) P39RT(2)	U39RT(2) S39RT(2)	C39R(1) C36AR(1)	L39RT(1) L36ART(1)	HYDRAULIC: Y644 (1) Y81KFT (3) Y4PC834 (3)	1-15/16"
YA40L	ORANGE	25	ORANGE DIE SET NEST INDENTOR	----	----	----	----	----	----	P40RT(3)	S40RT(3)	C40R(1)	L40RT(1)			
YA41L	GOLD	26	GOLD DIE SET NEST INDENTOR	----	----	----	----	----	----	P41D(1)	----	C41D(1)	----			

NOTES:

- MATERIAL: COPPER TUBING.
- FINISH: TIN PLATED.  
"FOR ALTERNATIVE FINISH ADD ONE OF THE FOLLOWING SUFFIXES:  
NICKEL = NK, LEAD = LD, BARE = BR"
- CATALOG # PT6515 ADAPTOR IS REQUIRED TO USE "U" DIES IN Y45 SERIES TOOLS.
- CATALOG # PUADP-1 ADAPTOR IS REQUIRED TO USE "U" DIES IN Y46 SERIES TOOLS.
- PERMANENT DIE IN TOOLING.
- DIMENSIONS IN BRACKETS [ ] ARE IN MILLIMETERS ROUNDED OFF TO THE NEAREST MILLIMETER, UNLESS OTHERWISE NOTED, AND ARE FOR REFERENCE ONLY.
- FOR USE BY CUSTOMERS THAT HAVE THIS HYPRESS™. NO NEW Y34A HYPRESS™ TOOLS ARE BEING PROCESSED. Y34A USES A--D NEST DIES ONLY.
- CONNECTORS ARE UL LISTED; UNDRILLED VERSIONS ARE NOT UL LISTED.
- CONNECTORS ARE CSA CERTIFIED. UNDRILLED VERSIONS ARE NOT CSA CERTIFIED.
- FOR UNDRILLED VERSIONS ADD SUFFIX "-U" TO END OF CATALOG NUMBER.  
FOR UNDRILLED VERSIONS, USE D MIN. = N MAX. + Z MIN.
- "X", "W-RT", "W-VT", "U" & "L" DIE SETS ARE COLOR CODED. "A", "B" AND "C" DIES ARE NOT COLOR CODED. NESTS AND INDENTOR TYPE ARE NOT COLOR CODED.

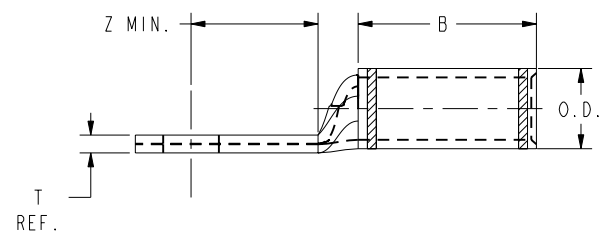
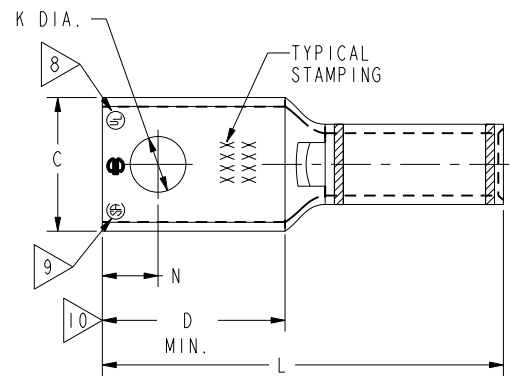

REFERENCE: SE209240

TO ORDER BURNDY® PRODUCTS CALL  
UNITED STATES  
1-800-346-4175 (LONDONDERRY, NH)  
CANADA:  
1-800-361-6975 (QUEBEC)  
1-800-387-6487 (ALL OTHER PROVINCES)  
FOR PRODUCT INFO: <http://www.burndy.com>

COPPER HYLUG™	
ITEM NO:	N/A
CAT. NO:	YA-L, YA-L-TC-, YAV-TC-
DRAWN BY:	J MICHAUD 8/17/94
CHECKER:	D FILLION 10/3/94
DSN APPVL:	C PALAGI 8/19/94
MFG APPVL:	N/A N/A
QA APPVL:	C ACKERMAN 9/30/94
MKT APPVL:	T NELSON 9/7/94
PROD FAM:	CM&R COMPRESSION
PROJECT #:	---
DOCUMENT TYPE:	Sales
REL LEVEL:	Released
DRAWING NO	SD079848
SCALE:	1:1
SIZE	D
SHEET	15 OF 17

REV: PE0200