

DRAWING NO.
SE209240

CATALOG NUMBER	STRANDED COPPER CONDUCTOR ACCOMMODATED			BOLT SIZE	METRIC BOLT SIZE	FIG. NO.	DIMENSIONS								
	CODE (AWG)	NAVY	METRIC SIZE (CLASS 2)				B	C	H REF.	K DIA.	L	N	O.D.	T REF.	Z MIN.
YAICL645	#1 AWG	75	-----	1/2	M12	1	.88 [22]	.73 [19]	1.25 [32]	.53 [13]	2.22 [56]	.53 [13]	.46 [12]	.09 [2]	.55 [14]
YAICL690						2	.88 [22]	.73 [19]	1.43 [36]	.53 [13]	1.40 [36]	.53 [13]	.46 [12]	.09 [2]	.55 [14]

REV	DATE	DESCRIPTION	ECO	BY	C'H'K.
B	11/04/2011 09:30:00 AM	UPDATED TOOLING DETAILS AS PER MU	25809	BT	MA

CONNECTOR SIZE	TOLERANCES					
	B	C	K DIA.	L	N	O.D.
-8C THRU -25	±.06	±.04	±.02	±.09	±.03	±.01
-26 THRU -34	±.08	±.04	±.02	±.12	±.03	±.01
-35 AND UP	±.09	±.06	±.02	±.15	±.06	±.01

TOLERANCE BLOCK

D

D

INSTALLATION TOOLING (# CRIMPS)																
CATALOG NO.	COLOR CODE	DIE INFORMATION		MECHANICAL RATCHET				HYDRAULIC						DIELESS (# CRIMPS)	WIRE STRIP LENGTH	
		DIE INDEX	TYPE	6 YIMRTC	OUR840	MD6 MD7	MD6--R2 MD7-34R	PATMD6 PAT600	8 Y34A Y34B Y34BH	5 Y35, Y39 Y750, PAT750	5 4 Y46 PAT46	5 3 Y45	Y48B			Y60BHU
YAICL645	GREEN	11 375	GREEN DIE SET	GREEN(2)	XICRT-1(1)	XICRT-1(1) WICRT-1(1) WICVT(1)	XICRT-1(1) WICRT-1(1) WICVT(1)	XICRT-1(1) WICRT-1(1) WICVT(1)	-----	UICRT-1(1) U4CABT(1)	UICRT-1(1) U4CABT(1)	UICRT-1(1) U4CABT(1)	-----	-----	MECHANICAL: MY29-3(1) MY29-11(1) MRC840(1) HYDRAULIC: Y644(1) Y81KFT(1) Y4PC834(1)	15/16"
YAICL690			NEST	-----	-----	-----	-----	-----	BICD(1) AICD(1)	UICD-1(1)	UICD-1(1)	UICD-1(1)	-----	-----		
			INDENTOR	-----	-----	-----	-----	-----	-----	Y34PR	Y34PR	Y34PR	Y34PR	-----		

C

C

NOTES:

- MATERIAL : COPPER TUBING.
- FINISH: ELECTRO-TIN PLATED.
- CATALOG # PT6515 ADAPTOR IS REQUIRED TO USE "U" DIES IN Y45 SERIES TOOLS.
- CATALOG # PUADP-1 ADAPTOR IS REQUIRED TO USE "U" DIES IN Y46 SERIES TOOLS.
- Y35P3 INDENTOR ADAPTOR REQUIRED FOR Y34PR INDENTOR.
- PERMANENT DIE IN TOOLING.
- DIMENSIONS IN BRACKETS [] ARE IN MILLIMETERS ROUNDED OFF TO THE NEAREST MILLIMETER, UNLESS OTHERWISE NOTED, AND ARE FOR REFERENCE ONLY.
- FOR USE BY CUSTOMERS THAT HAVE THIS HYPRESS™. NO NEW Y34A HYPRESS™ TOOLS ARE BEING PROCESSED. Y34A USES A--D NEST DIES ONLY.
- CONNECTORS ARE UL LISTED; UNDRILLED VERSIONS ARE NOT UL LISTED.
- CONNECTORS ARE CSA CERTIFIED; UNDRILLED VERSIONS ARE NOT CSA CERTIFIED.
- FOR UNDRILLED VERSIONS ADD SUFFIX "-U" TO END OF CATALOG NUMBER. FOR UNDRILLED VERSIONS, USE D MIN. = N MAX. + Z MIN.
- "X", "W-RT", "W-VT", "U", & "L" DIE SETS ARE COLOR CODED. "A", "B", AND "C" DIES ARE NOT COLOR CODED. NESTS AND INDENTOR TYPE ARE NOT COLOR CODED.

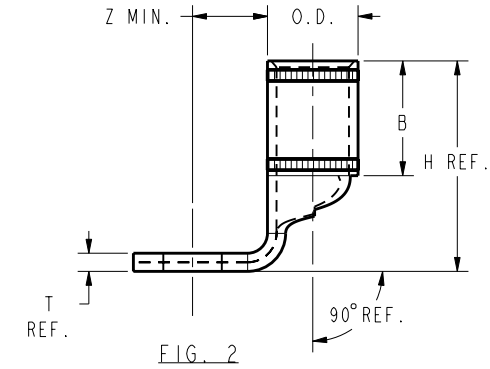
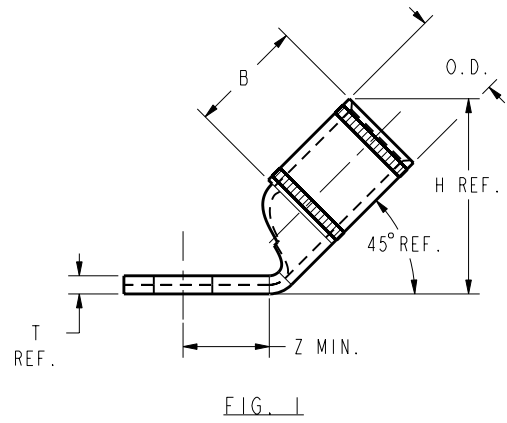
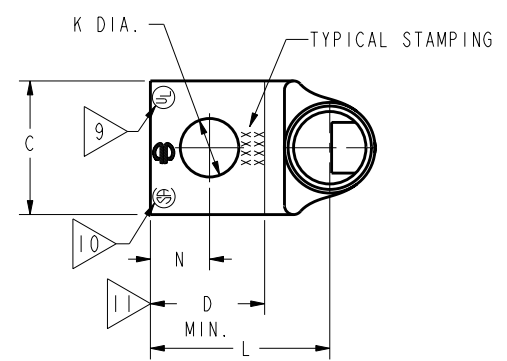
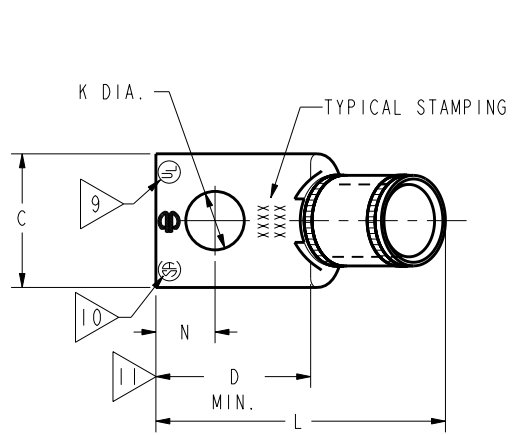

REFERENCE: SD079848

TO ORDER BURNDY® PRODUCTS CALL		COPPER HYLUG™	
UNITED STATES 1-800-346-4175 (LONDONDERRY, NH)		ITEM NO: N/A	CAT. NO: YAIC-L-- (TABLE)
CANADA: 1-800-361-6975 (QUEBEC) 1-800-387-6487 (ALL OTHER PROVINCES)		DRAWN BY: J MICHAUD 12/08/94	CHECKER: D FELLION 12/08/94
FOR PRODUCT INFO: http://www.burndy.com		DSN APPVL: C PALAGI 12/08/94	MFG APPVL: --
		QA APPVL: C ACKERMAN 12/23/94	MKT APPVL: T NELSON 12/15/94
		PROJ #: --	SCALE: 1:1
		PROJ #: --	SIZE: D
		DOCUMENT TYPE: Sales	DRAWING NO: SE209240
		REL LEVEL: Released	REV: B
			SHEET 11 OF 38

REV: PE0200

8

7

6

5

4

3

2

1

A

B

B