

DRAWING NO.  
SE209240

CATALOG NUMBER	STRANDED COPPER CONDUCTOR ACCOMMODATED			BOLT SIZE	METRIC BOLT SIZE	FIG. NO.	DIMENSIONS								
	CODE (AWG)	NAVY	METRIC SIZE (CLASS 2)				B	C	H REF.	K DIA.	L	N	O.D.	T REF.	Z MIN.
YA27L245	3/0 AWG	150	-----	1/4	M6	1	1.00 [25]	.91 [23]	1.49 [38]	.27 [7]	1.91 [49]	.25 [6]	.62 [16]	.13 [3]	.33 [8]
2						1.66 [42]	.27 [7]	.99 [25]	.25 [6]	.62 [16]	.13 [3]	.33 [8]			
YA27L290				1	1.49 [38]	.33 [8]	2.03 [52]	.34 [9]	.62 [16]	.13 [3]	.36 [9]				
YA27L345				2	1.66 [42]	.33 [8]	1.12 [28]	.34 [9]	.62 [16]	.13 [3]	.36 [9]				
YA27L390				1	1.49 [38]	.40 [10]	2.16 [55]	.41 [10]	.62 [16]	.13 [3]	.42 [11]				
YA27L445				2	1.66 [42]	.40 [10]	1.24 [31]	.41 [10]	.62 [16]	.13 [3]	.42 [11]				

REV	DATE	DESCRIPTION	ECO	BY	C'H'K.
B	11/04/2011 09:30:00 AM	UPDATED TOOLING DETAILS AS PER MU	25809	BT	MA

CONNECTOR SIZE	TOLERANCES					
	B	C	K DIA.	L	N	O.D.
-8C THRU -25	±.06	±.04	±.02	±.09	±.03	±.01
-26 THRU -34	±.08	±.04	±.02	±.12	±.03	±.01
-35 AND UP	±.09	±.06	±.02	±.15	±.06	±.01

TOLERANCE BLOCK

INSTALLATION TOOLING (# CRIMPS)																
CATALOG NO.	COLOR CODE	DIE INFORMATION		MECHANICAL RATCHET				HYDRAULIC					DIELESS (# CRIMPS)	WIRE STRIP LENGTH		
		DIE INDEX	TYPE	6 YIMRTC	OUR840	MD6 MD7	MD6--R2 MD7-34R	PATMD6 PAT600	8 Y34A Y34B Y34BH	5 Y35, Y39 Y750, PAT750	5 4 Y46 PAT46	5 3 Y45			Y48B	Y60BHU
YA27L45	ORANGE	14	ORANGE DIE SET	-----	X27RT(3)	X27RT(2) W27RT(2) W27VT(2)	X27RT(2) W27RT(2) W27VT(2)	X27RT(2) W27RT(2) W27VT(2)	-----	U27RT(1)	U27RT(1)	U27RT(1)	-----	-----	MECHANICAL: MY29-3(1) MY29-11(1) MRC840(2)  HYDRAULIC: Y644(1) Y81KFT(2) Y4PC834(2)	1-1/16"
YA27L90			NEST INDENTOR	-----	-----	-----	-----	B27D(1) A27D(1) Y34PR	U27D-1(1) Y34PR	U27D-1(1) Y34PR	U27D-1(1) Y34PR	-----	-----			

NOTES:

- MATERIAL : COPPER TUBING.
- FINISH: ELECTRO-TIN PLATED.
- CATALOG # PT6515 ADAPTOR IS REQUIRED TO USE "U" DIES IN Y45 SERIES TOOLS.
- CATALOG # PUADP-1 ADAPTOR IS REQUIRED TO USE "U" DIES IN Y46 SERIES TOOLS.
- Y35P3 INDENTOR ADAPTOR REQUIRED FOR Y34PR INDENTOR.
- PERMANENT DIE IN TOOLING.
- DIMENSIONS IN BRACKETS [ ] ARE IN MILLIMETERS ROUNDED OFF TO THE NEAREST MILLIMETER, UNLESS OTHERWISE NOTED, AND ARE FOR REFERENCE ONLY.
- FOR USE BY CUSTOMERS THAT HAVE THIS HYPRESS™. NO NEW Y34A HYPRESS™ TOOLS ARE BEING PROCESSED. Y34A USES A--D NEST DIES ONLY.
- CONNECTORS ARE UL LISTED; UNDRILLED VERSIONS ARE NOT UL LISTED.
- CONNECTORS ARE CSA CERTIFIED; UNDRILLED VERSIONS ARE NOT CSA CERTIFIED.
- FOR UNDRILLED VERSIONS ADD SUFFIX "-U" TO END OF CATALOG NUMBER. FOR UNDRILLED VERSIONS, USE D MIN. = N MAX. + Z MIN.
- "X", "W-RT", "W-VT", "U", & "L" DIE SETS ARE COLOR CODED. "A", "B", AND "C" DIES ARE NOT COLOR CODED. NESTS AND INDENTOR TYPE ARE NOT COLOR CODED.

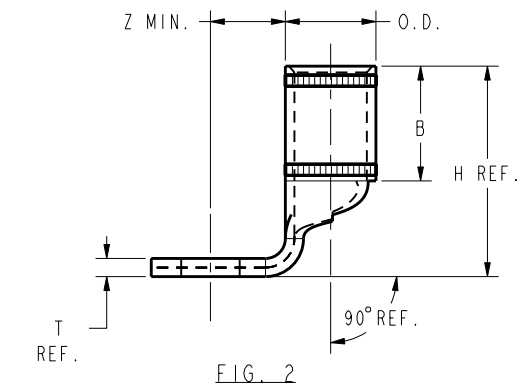
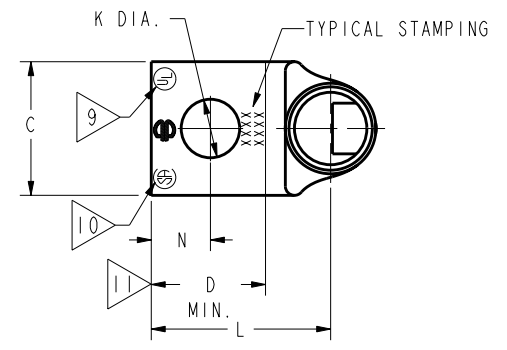
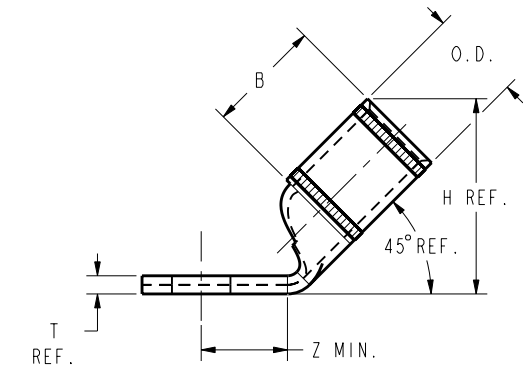
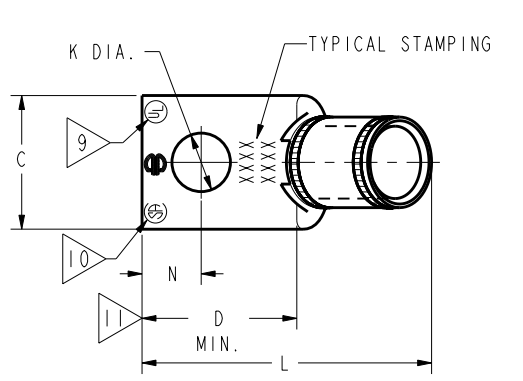

REFERENCE: SD079848

TO ORDER BURNDY® PRODUCTS CALL		COPPER HYLUG™	
UNITED STATES 1-800-346-4175 (LONDONDERRY, NH)		ITEM NO: N/A	CAT. NO: YA27-L-- (TABLE)
CANADA: 1-800-361-6975 (QUEBEC) 1-800-387-6487 (ALL OTHER PROVINCES)		DRAWN BY: J MICHAUD 12/08/94	CHECKER: D FELLION 12/08/94
FOR PRODUCT INFO: <a href="http://www.burndy.com">http://www.burndy.com</a>		DSN APPVL: C PALAGI 12/08/94	MFG APPVL: --
		QA APPVL: C ACKERMAN 12/23/94	MKT APPVL: T NELSON 12/15/94
		PROD FAM: CM&R COMPRESSION	DRAWING NO: SE209240
		PROJECT #: --	SCALE: 1:1
		DOCUMENT TYPE: Sales	REV: B
		REL LEVEL: Released	SHEET 16 OF 38

REV: PE0200