

DRAWING NO. SE209241		7		6		5		4		3		2		1								
10 CATALOG NUMBER	STRANDED COPPER CONDUCTOR ACCOMMODATED			BOLT SIZE	METRIC BOLT SIZE	FIG. NO.	DIMENSIONS							REV	DATE	DESCRIPTION	ECO	BY	C'H'K.			
	CODE (AWG)	NAVY	METRIC SIZE (CLASS 2)				B	C	H REF.	K DIA.	L	N	O.D.	T REF.	Z MIN.	B	11/09/2011 00:00:00 AM	TOOLING DETAILS UPDATED AS PER MARKUP	25811	DK	MA	
	YA3845	700 kcmil	-----				5/8	M16	1	2.81 [71]	1.84 [47]	3.60 [91]	.69 [18]	4.60 [117]	.66 [17]	1.25 [32]	.27 [7]	.67 [17]				
	YA3890								2	4.21 [107]	.69 [18]	2.15 [55]	.66 [17]	.67 [17]								
	YA38N45								1	3.60 [91]	.56 [14]	4.53 [115]	.63 [16]	.64 [16]								
YA38N90	2			2.81 [71]	1.84 [47]	4.21 [107]			.56 [14]	2.08 [53]	.63 [16]	1.25 [32]	.27 [7]	.64 [16]								

CONNECTOR SIZE	TOLERANCES					
	B	C	K DIA.	L	N	O.D.
-8C THRU -25	±.06	±.04	±.02	±.09	±.03	±.01
-26 THRU -34	±.08	±.04	±.02	±.12	±.03	±.01
-35 AND UP	±.09	±.06	±.02	±.15	±.06	±.01

TOLERANCE BLOCK

INSTALLATION TOOLING (# CRIMPS)																
CATALOG NO.	DIE INFORMATION			MECHANICAL RATCHET				HYDRAULIC						DIELESS (# CRIMPS)	WIRE STRIP LENGTH	
	COLOR CODE	DIE INDEX	TYPE	5 YIMRTC	OUR840	MD6 MD7	MD6--R2 MD7-34R	PATMD6 PAT600	7 Y34A Y34B Y34BH	Y35, Y39 Y750, BAT35 PAT750	4 Y46 PAT46	3 Y45	Y48B			Y60BHU
YA3845 YA3890 YA38N45 YA38N90	PINK	400	PINK DIE SET	-----	-----	-----	-----	-----	-----	U38RT(4)	U38RT(4)	U38RT(4)	-----	L38RT(2)	HYDRAULIC: Y644(1) Y81KFT(4) YY4PC834(4)	2-7/8"
			NEST INDENTOR	-----	-----	-----	-----	-----	-----	-----	P38D(2) P44PR	-----	C38D(2) Y48PR	-----		

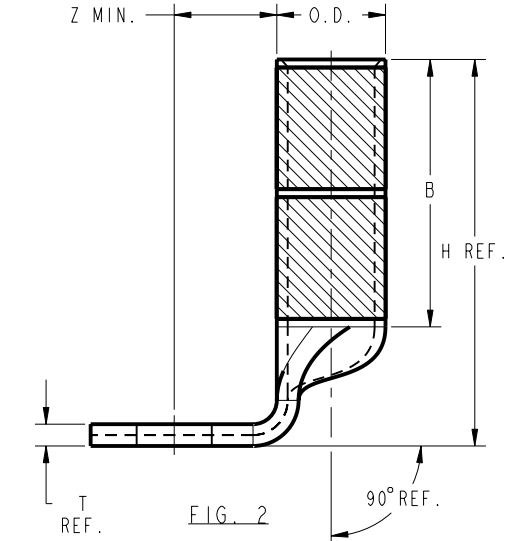
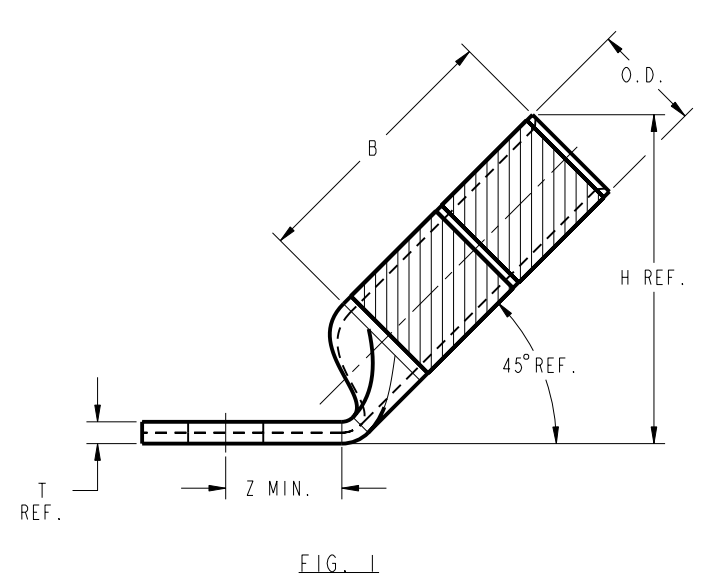
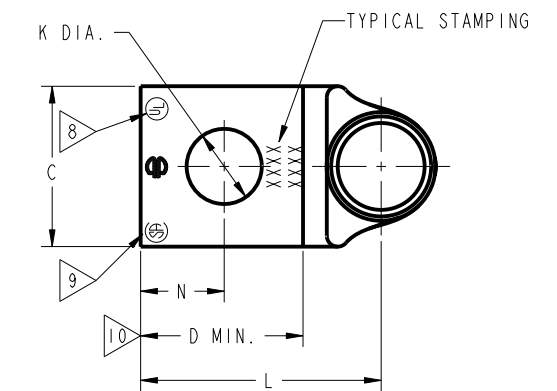
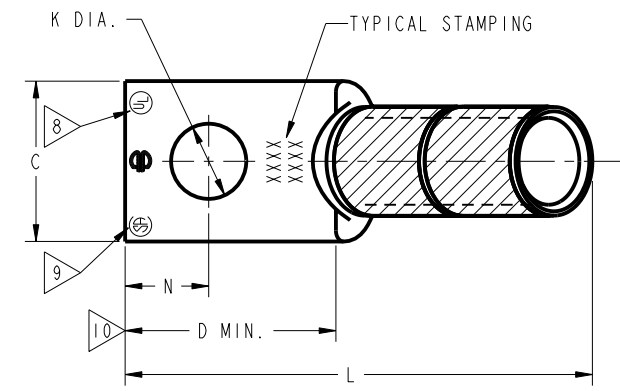

NOTES:

- MATERIAL : COPPER TUBING.
- FINISH: ELECTRO-TIN PLATED.
- CATALOG # PT6515 ADAPTOR IS REQUIRED TO USE "U" DIES IN Y45 SERIES TOOLS.
- CATALOG # PUADP-1 ADAPTOR IS REQUIRED TO USE "U" DIES IN Y46 SERIES TOOLS.
- PERMANENT DIE IN TOOLING.
- DIMENSIONS IN BRACKETS [] ARE IN MILLIMETERS ROUNDED OFF TO THE NEAREST MILLIMETER, UNLESS OTHERWISE NOTED, AND ARE FOR REFERENCE ONLY.
- FOR USE BY CUSTOMERS THAT HAVE THIS HYPRESS™. NO NEW Y34A HYPRESSES™ ARE BEING PROCESSED. Y34A USES A--D NEST DIES ONLY.
- CONNECTORS ARE UL LISTED; UNDRILLED VERSIONS ARE NOT UL LISTED.
- CONNECTORS ARE CSA CERTIFIED; UNDRILLED VERSIONS ARE NOT CSA CERTIFIED.
- FOR UNDRILLED VERSIONS ADD SUFFIX "-U" TO END OF CATALOG NUMBER. FOR UNDRILLED VERSIONS, USE D MIN. = N MAX. + Z MIN.
- "X", "W-RT", "W-VT", "U", & "L" DIE SETS ARE COLOR CODED. "A", "B", AND "C" DIES ARE NOT COLOR CODED. NESTS AND INDENTOR TYPE ARE NOT COLOR CODED.

REFERENCE: SD79849

TO ORDER BURNDY® PRODUCTS CALL		COPPER HYLUG™	
UNITED STATES 1-800-346-4175 (LONDONDERRY, NH)		ITEM NO: N/A	CAT. NO: YA-45, -90 / YA-N-45, -90
CANADA: 1-800-361-6975 (QUEBEC) 1-800-387-6487 (ALL OTHER PROVINCES)		DRAWN BY: J. MITCHAUD 1/17/95	CHECKER: D. FILLION 1/17/95
FOR PRODUCT INFO: http://www.burndy.com		DSN APPVL: C. PALAGI 1/18/95	MFG APPVL: N/A
		QA APPVL: C. ACKERMAN 2/03/95	MKT APPVL: T. NELSON 1/20/95
		PROJ #:	SCALE: NTS
		DOCUMENT TYPE: Sales	DRAWING NO: SE209241
		REL LEVEL: Released	REV: B
		SIZE: D	SHEET 24 OF 32

REV: PE0200