

DRAWING NO.
SE209512

CATALOG NUMBER	STRANDED COPPER CONDUCTOR ACCOMMODATED			BOLT SIZE	METRIC BOLT SIZE	FIG. NO.	DIMENSIONS									
	CODE (AWG)	NAVY	METRIC SIZE (CLASS 2)				B	C	E	H REF	K DIA	L	N	O.D.	T REF	Z MIN
YA1CL2TC1445	#1 AWG	75	-----	1/4	M6	1	.88 [22]	.68 [17]	.63 [16]	1.21 [31]	.27 [7]	2.40 [61]	.31 [8]	.46 [12]	.10 [3]	.33 [8]
YA1CL2TC1490						2	.63 [16]	1.40 [36]	.27 [7]	1.60 [41]	.31 [8]	.46 [12]	.10 [3]	.33 [8]		
YA1CL2TC14E245						1	.75 [19]	1.21 [31]	.27 [7]	2.52 [64]	.31 [8]	.46 [12]	.10 [3]	.33 [8]		
YA1CL2TC14E290						2	.75 [19]	1.40 [36]	.27 [7]	1.73 [44]	.31 [8]	.46 [12]	.10 [3]	.33 [8]		
YA1C2L45						1	.88 [22]	1.21 [31]	.33 [8]	2.71 [69]	.34 [9]	.46 [12]	.10 [3]	.36 [9]		
YA1C2L90						2	.88 [22]	1.40 [36]	.33 [8]	1.92 [49]	.34 [9]	.46 [12]	.10 [3]	.36 [9]		

REV	DATE	DESCRIPTION	ECO	BY	CHK	MA
A	6/12/2010 10:00:00 AM	REDRAWN IN PROE	20979	DK		

CONNECTOR SIZE	TOLERANCES						
	B	C	E	K DIA	L	N	O.D.
-8C THRU -25	±.06	±.04 ±.02	±.02	±.02	±.09	±.03	±.01
-26 THRU -34	±.08	±.04 ±.02	±.02	±.02	±.12	±.03	±.01
-35 AND UP	±.09	±.06	±.02	±.02	±.15	±.06	±.01

TOLERANCE BLOCK

INSTALLATION TOOLING (# CRIMPS)

CATALOG NO.	COLOR CODE	DIE INFORMATION		MECHANICAL RATCHET				HYDRAULIC				DIELESS (# CRIMPS)	WIRE STRIP LENGTH			
		DIE INDEX	TYPE	Y2MR	OUR840	MD6 MD7	MD6--R2 BAT500	MD7-34R	Y34A Y34B Y34BH	Y35, Y39 Y750, BAT35 BAT750	Y46			Y45	Y48B	Y60BHU
YA1CL2TC1445 YA1CL2TC1490 YA1CL2TC14E245 YA1CL2TC14E290 YA1C2L45 YA1C2L90	GREEN	11 375	GREEN DIE SET NEST INDENTOR	-----	XICRT-1(1)	WICRT-1(1) WICVT(1)	WICRT-1(1) WICVT(1)	WICRT-1(1) WICVT(1)	-----	UICRT-1(1) U4CABT(1)	UICRT-1(1) U4CABT(1)	UICRT-1(1) U4CABT(1)	-----	-----	MECHANICAL: MY29-3(1) MY29-11(1) HYDRAULIC, Y644M(1) BAT644M(1)	15/16"
				-----	-----	-----	-----	-----	BICD(1) AICD(1) Y34PR	UICD-1(1) Y34PR	UICD-1(1) Y34PR	UICD-1(1) Y34PR				

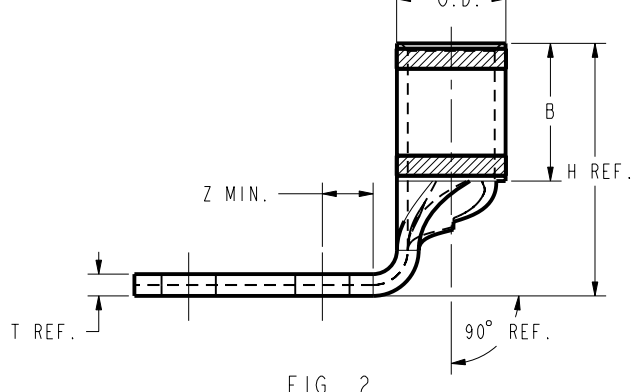
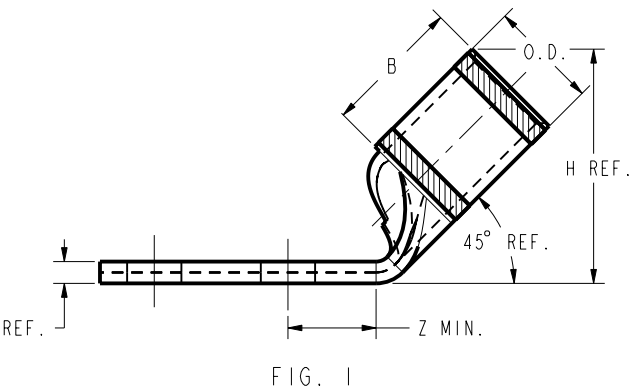
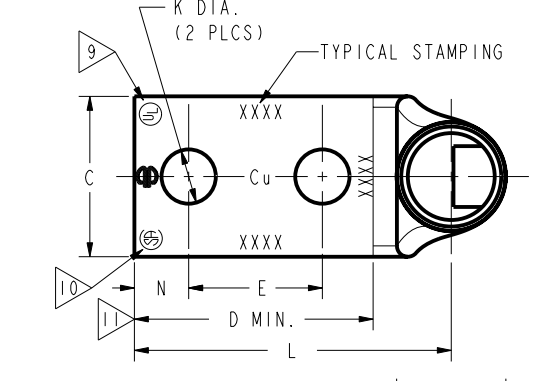
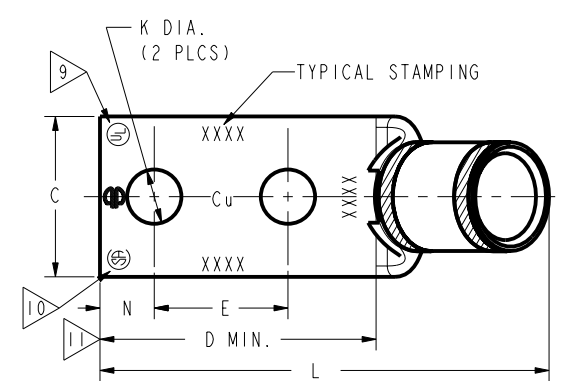

- NOTES:
- MATERIAL: COPPER TUBING.
 - FINISH: ELECTRO-TIN PLATED.
 - CATALOG # PT6515 ADAPTOR IS REQUIRED TO USE "U" DIES IN Y45 SERIES TOOLS.
 - CATALOG # PUADP-1 ADAPTOR IS REQUIRED TO USE "U" DIES IN Y46 SERIES TOOLS.
 - Y35P3 INDENTOR ADAPTOR REQUIRED FOR Y34PR INDENTOR.
 - PERMANENT DIE IN TOOLING.
 - DIMENSIONS IN BRACKETS [] ARE IN MILLIMETERS ROUNDED OFF TO THE NEAREST MILLIMETER, UNLESS OTHERWISE NOTED, AND ARE FOR REFERENCE ONLY.
 - FOR USE BY CUSTOMERS THAT HAVE THIS HYPRESS™. NO NEW Y34A HYPRESS™ TOOLS ARE BEING PROCESSED. Y34A USES A--D NEST DIES ONLY.
 - CONNECTORS ARE UL LISTED, UNDRILLED VERSIONS ARE NOT UL LISTED.
 - CONNECTORS ARE CSA CERTIFIED, UNDRILLED VERSIONS ARE NOT CSA CERTIFIED.
 - FOR UNDRILLED VERSIONS ADD SUFFIX "-U" TO END OF CATALOG NUMBER. FOR UNDRILLED VERSIONS, USE D MIN. = N MAX. + E MIN. + Z MIN.
 - "X", "W-RT", "W-VT", "U", & "L" DIE SETS ARE COLOR CODED. "A", "B", AND "C" DIES ARE NOT COLOR CODED. NESTS AND INDENTOR TYPE ARE NOT COLOR CODED.

REFERENCE: SD035209

TO ORDER BURNDY® PRODUCTS CALL		COPPER HYLUG™	
UNITED STATES 1-800-346-4175 (LONDONDERRY, NH)		ITEM NO: --	SCALE: 3:2
CANADA: 1-800-361-6975 (QUEBEC) 1-800-387-6487 (ALL OTHER PROVINCES)		CAT. NO: YA-L-2TC-45-90/YA--2L-45-90, YA--2LN-45-90/YA-4L-45-90	REV
FOR PRODUCT INFO: http://www.burndy.com		DRAWN BY: J. MICHAUD 02/03/95	SIZE
		CHECKER: D. FILLION 02/21/95	SE209512
		DSN APPVL: C. PALAGI 03/09/95	SHEET 15 OF 52
		MFG APPVL: N/A	A
		QA APPVL: C. ACKERMAN 04/03/95	
		MKT APPVL: T. NELSON 03/13/95	
		PROJ #:	
		REL LEVEL: Released	

REV: PE0200