

REV	DATE	DESCRIPTION	ECO	BY	C'H'K.
A	4/11/2008 12:00:00 AM	REDRAW INTO PRO-E & CATALOG NUMBER UPDATION	16757	DG	BSK

CATALOG NO.	CONDUCTOR		BOLT SIZE	FIG. NO.	DIMENSIONS									INSTALLATION TOOLING (# CRIMPS)															
	CODE (AWG)	NAVY			B	C	E	H REF.	K DIA.	L	N	O.D.	T REF.	Y MIN.	DIE INDEX	COLOR CODE	MECHANICAL RATCHET		HYDRAULIC				DIELESS (# CRIMPS)	WIRE STRIP LENGTH					
																	MD7-34R MD6	OUR840	Y34A	Y750 Y35, BAT35 Y39, BAT750	Y46	Y45			Y48B	Y60B			
YAZ292TC38	250 Kcmil [120mm ² STR]	250	3/8 [M10]	1	1.62 [41]	1.10 [28]	1.00 [25]	----	.40 [10]	.41 [10]	.75 [19]	.14 [4]	1.43 [36]	16	YELLOW	W29VT W29RT (4)	X29RT (6)	A29R (2)	U29RT (2)	U29RT (2)	U29RT (2)	C29R (2)	L29RT (1)	HYDRAULIC: Y644, Y644M Y644MBH, Y1000 Y1000BH (1)	1-11/16				
YAZ292TC3845				2.09 [53]				3.73 [95]																		2.34 [59]	2.83 [72]	.16 [4]	1.93 [49]
YAZ292TC3890				2.42 [61]																									
YAZ292TC3890GI																													

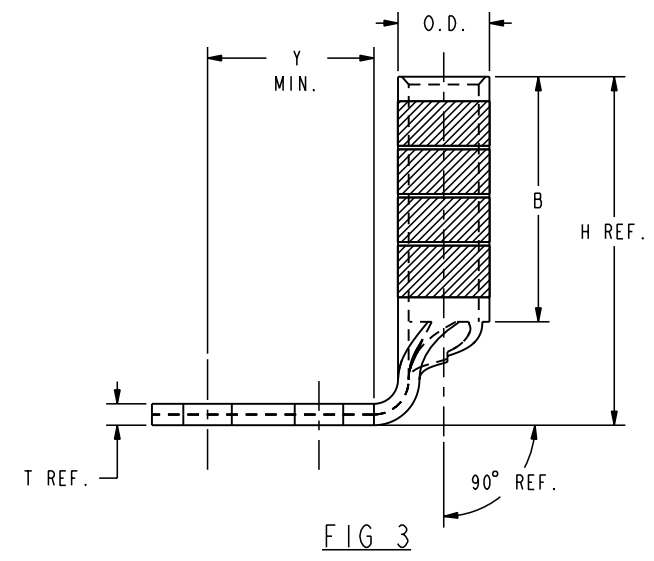
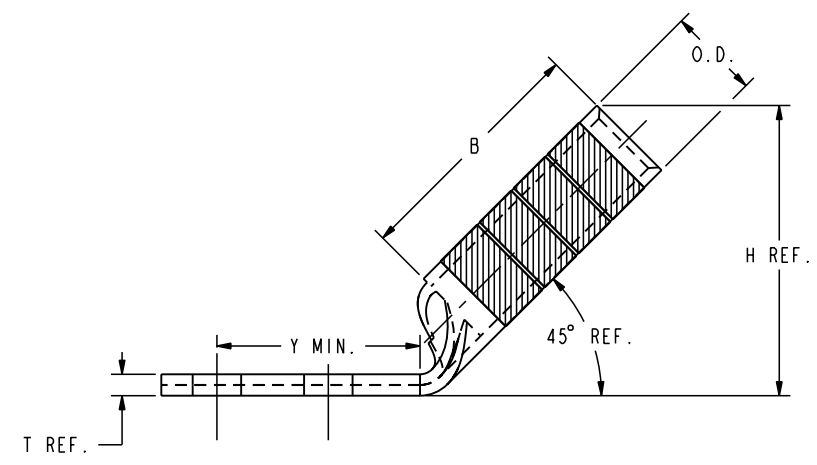
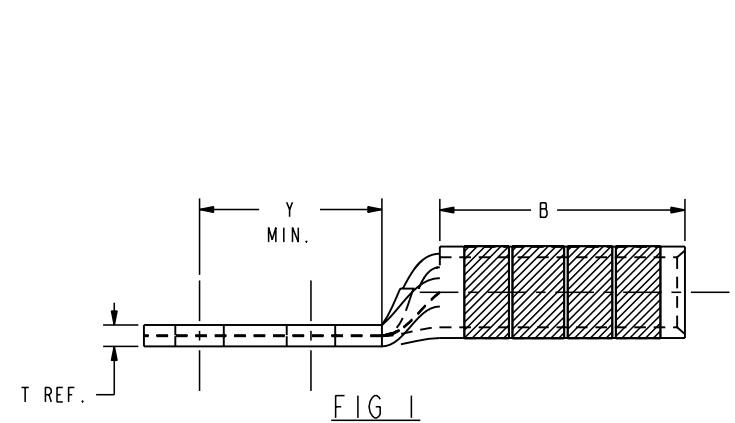
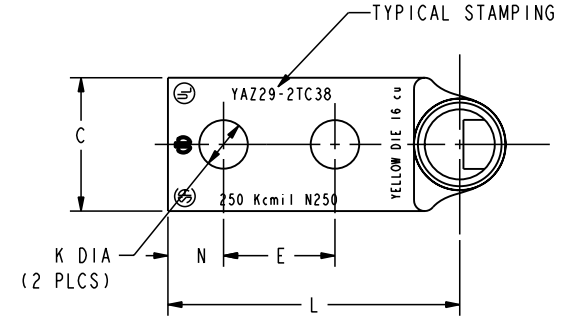
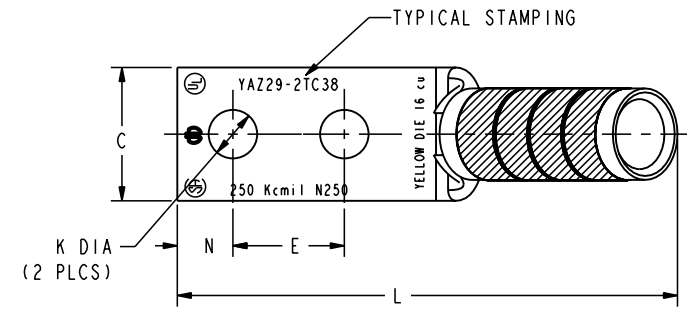
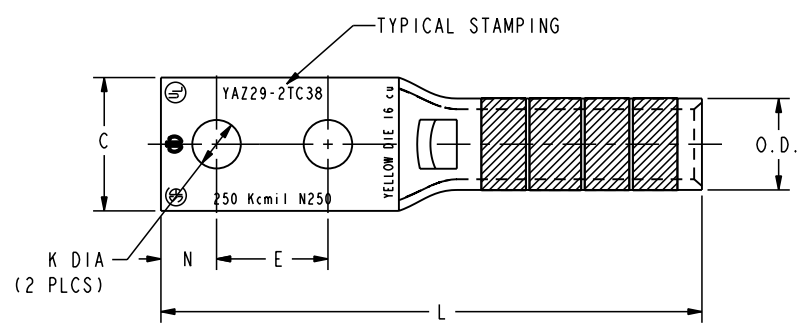

- NOTES:
- MATERIAL: COPPER TUBING.
 - FINISH: TIN PLATED
 - CATALOG # PT6515 ADAPTOR IS REQUIRED TO USE "U" DIES IN Y45 SERIES TOOLS.
 - CATALOG # PUADP-1 ADAPTOR IS REQUIRED TO USE "U" DIES IN Y46 SERIES TOOLS.
 - NAVY CABLE SIZE MAY BE OMITTED ON SOME SIZES BECAUSE OF SPACE LIMITATIONS.
 - DIMENSIONS, METRIC WIRE, & METRIC BOLT SIZES IN BRACKETS [] ARE IN MILLIMETERS. DIMENSIONS ARE ROUNDED OFF TO THE NEAREST MILLIMETER, UNLESS OTHERWISE NOTED, AND ARE FOR REFERENCE ONLY.
 - FOR USE BY CUSTOMERS THAT HAVE THIS HYPRESS™ NO NEW Y34A HYPRESS™ ARE BEING PROCESSED.
 - OVERLAPPING CRIMPS ARE REQUIRED ON THESE SIZES.

TO ORDER BURNDY® PRODUCTS CALL UNITED STATES 1-800-346-4175 (LONDONDERRY, NH) CANADA: 1-800-361-6975 (QUEBEC) 1-800-387-6487 (ALL OTHER PROVINCES) FOR PRODUCT INFO: http://www.burndy.com	HYLUG™	
	ITEM NO:	N/A
	CAT. NO:	YAZ29-2TC- (SEE TABLE)
	DRAWN BY:	D. BOISVERT 11/12/98
	CHECKER:	K. HENRY 12/03/98
	DSN APPVL:	B. MACDONALD 12/02/98
	MFG APPVL:	N/A
	QA APPVL:	S. GARY 11/30/98
	MKT APPVL:	B. HARDGROVE 11/25/98
	PROJ #:	---
PROJECT #:	---	
DOCUMENT TYPE:	Sales	
REL LEVEL:	Released	
SCALE:	4:1	
DRAWING NO:	SE211915	
REV:	A	
SHEET:	29 OF 36	