

REV	DATE	DESCRIPTION	ECO	BY	C'H'K.
C	08/18/2015 00:00:00 AM	ADD NOTE 8	41306	BSB	RG

CATALOG NO.	CONDUCTOR		BOLT SIZE	FIG. NO.	DIMENSIONS										INSTALLATION TOOLING (# CRIMPS)																	
	FLEX	CODE (AWG)			B	C	E	H MAX.	K DIA.	L	N	O.D.	T REF.	Y MIN.	DIE INDEX	COLOR CODE	MECHANICAL				HYDRAULIC			DIELESS (# CRIMPS)	WIRE STRIP LENGTH							
																	MD7-34R	OUR840	Y2MR	BCT500 Y500CT	Y750 Y35, BAT35 Y39, BAT750	Y46	Y45									
YAZV6C2TC38E2FX	#6 WELD 61/24	#6 AWG	1	.75 [19]	.58 [15]	.75 [19]	---	.40 [10]	2.53 [64]	.41 [10]	.31 [8]	.06 [2]	1.18 [30]	7 OR 374	BLUE	7	7	BLUE (2)	7	7	7	7	7	MECHANICAL: MY29-11 (1) HYDRAULIC: Y644, Y644M Y644MBH, 1 CRIMP	1-3/16							
YAZV6C2TC38E2FX45	↑	↑	2	↑	↑	↑	↑	↑	↑	↑	↑	↑	↑	↑	↑	↑	↑	↑	↑	↑	↑	↑	↑	↑								
YAZV6C2TC38E2FX90			3																						1.00 [25]	1.82 [46]	W5CVT X5CRT W5CRT (2)	X5CRT W5CVT (2)	W5CVT X5CRT W5CRT (2)	U5CRT (2)	U5CRT (2)	U5CRT (2)
YAZV6C2TC38E6FX			1																						---	2.66 [68]	---	---	---	---	---	---
YAZV6C2TC38E6FX45	↓	↓	2	↓	↓	↓	↓	↓	↓	↓	↓	↓	↓	↓	↓	↓	↓	↓	↓	↓	↓	↓	↓	↓	↓							
YAZV6C2TC38E6FX90			3																							1.00 [25]	1.95 [50]	W5CVT X5CRT W5CRT (2)	X5CRT W5CVT (2)	W5CVT X5CRT W5CRT (2)	U5CRT (2)	U5CRT (2)

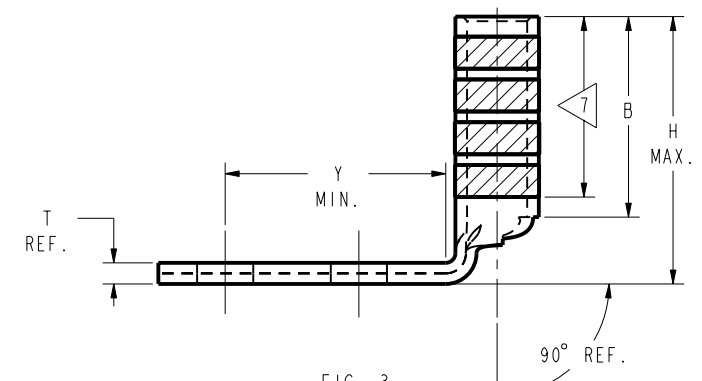
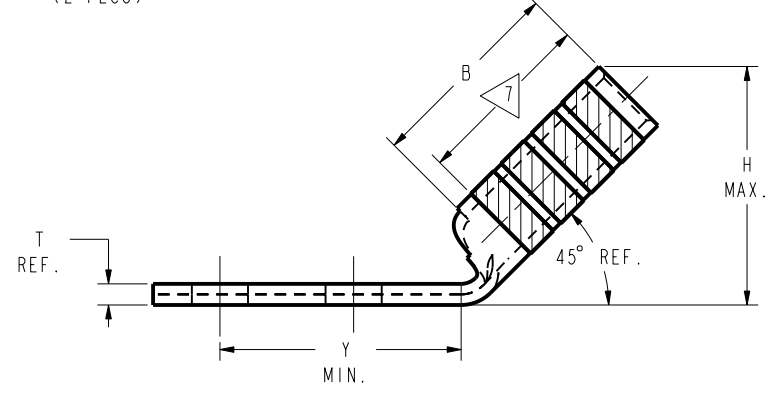
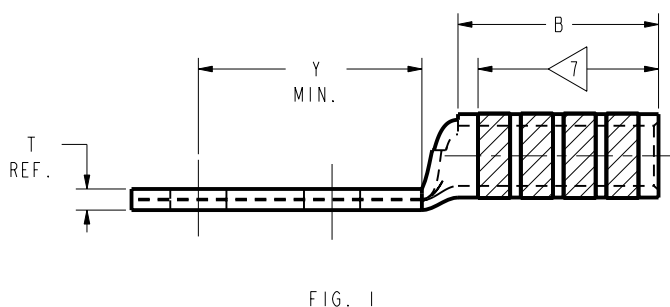
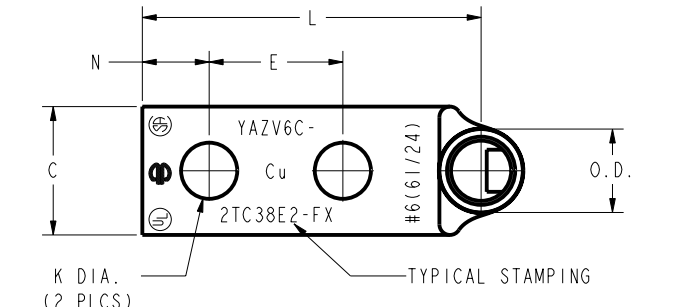
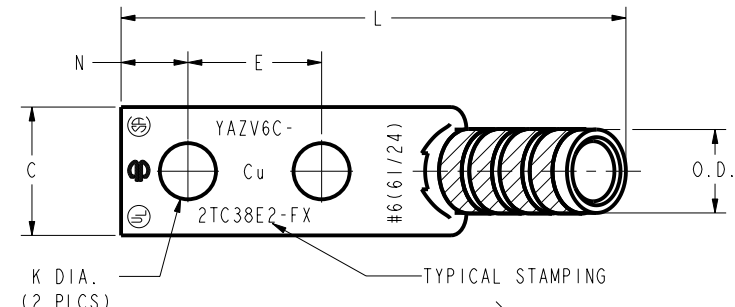
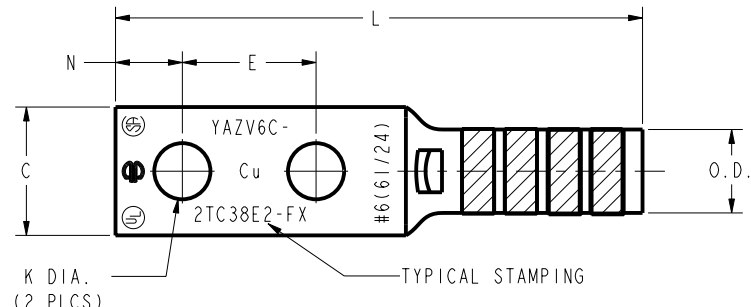

NOTES:

- MATERIAL: COPPER TUBING.
- FINISH: TIN PLATED.
- CATALOG # PT6515 ADAPTOR IS REQUIRED TO USE "U" DIES IN Y45 SERIES TOOLS.
- CATALOG # PUADP-1 ADAPTOR IS REQUIRED TO USE "U" DIES IN Y46 SERIES TOOLS.
- PERMANENT DIE IN TOOLING.
- DIMENSIONS IN BRACKETS [] ARE IN MILLIMETERS ROUNDED OFF TO THE NEAREST MILLIMETER, UNLESS OTHERWISE NOTED, AND ARE FOR REFERENCE ONLY.
- OVERLAP 2 CRIMPS AS NEEDED WITHIN THE LENGTH BETWEEN THE INK STAMPED CRIMPING AREA.
- THESE CATALOG NUMBERS CANNOT BE INSTALLED WITH U5CRT DIE.

TO ORDER BURNDY® PRODUCTS CALL		HYLUG™ (TWO HOLE FLEX)	
UNITED STATES 1-800-346-4175 (LONDONDERRY, NH)		ITEM NO: N/A	CAT. NO: YAZV6C--- (TABLE)
CANADA: 1-800-361-6975 (QUEBEC) 1-800-387-6487 (ALL OTHER PROVINCES)		DRAWN BY: D BOISVERT 8/19/99	CHECKER: K HENRY 8/26/99
FOR PRODUCT INFO: http://www.burndy.com		DSN APPVL: RR TEAM 9/28/99	MFG APPVL: --
		QA APPVL: J BRODEUR 10/6/99	MKT APPVL: R ROBICHEAU 10/5/99
		PROJ #:	SCALE: NTS
		SIZE: D	DRAWING NO: SE212273
		DOCUMENT TYPE: Sales	REV: C
		REL LEVEL: Released	SHEET 5 OF 48

REV: PE0200