

REV	DATE	DESCRIPTION	ECO	BY	C' H' K.
C	2022-10-25 00:00:00 EDT	UPDATED AS PER THE MARKUP	221025025108	RA	YR

CATALOG NO.	CONDUCTOR		BOLT SIZE	FIG. NO.	DIMENSIONS									INSTALLATION TOOLING (# CRIMPS)							
	FLEX	CODE (AWG)			B ±.09	C +.04 -.02	E ±.02	H REF.	K DIA. ±.02	L ±.12	N ±.03	O.D. ±.01	T REF.	Y MIN.	DIE INDEX	COLOR CODE	HYDRAULIC			DIELESS (# CRIMPS)	WIRE STRIP LENGTH
																	Y750 Y35, BAT35 Y39, BAT750	Y46 ◁4	Y45 ◁3		
YAZ362TC38FX	444 KCMIL DLO 500 KCMIL CLASS G,H	---	3/8 [M10]	1	2.69 [68]	1.74 [44]	1.00 [25]	---	.40 [10]	5.55 [141]	.50 [13]	1.19 [30]	.27 [7]	1.53 [39]	20 OR 299	BROWN	◁7	◁7	◁7	HYDRAULIC: Y644, Y644M Y644MBH, (1)	2-3/4
YAZ362TC38FX45				2	3.40 [86]			5.14 [131]		2.81 [71]											
YAZ362TC38FX90				3	3.99 [101]			2.81 [71]													
YAZ362NTCFX				1	1.74 [44]	1.75 [44]	---	6.55 [166]	.62 [16]	.27 [7]	2.40 [61]	U34RT (4)	U34RT (4)	U34RT (4)							
YAZ362NTCFX45				2			3.40 [86]	6.14 [156]				3.81 [97]									
YAZ362NTCFX90				3			3.99 [101]	3.81 [97]													
YAZ362TC58E16FX	444 KCMIL DLO 500 KCMIL CLASS G,H	---	5/8 [M16]	1	2.69 [68]	---	---	.69 [18]	6.61 [168]	.66 [17]	---	---	2.43 [62]	---	BROWN	---	---	---	---	---	2-3/4

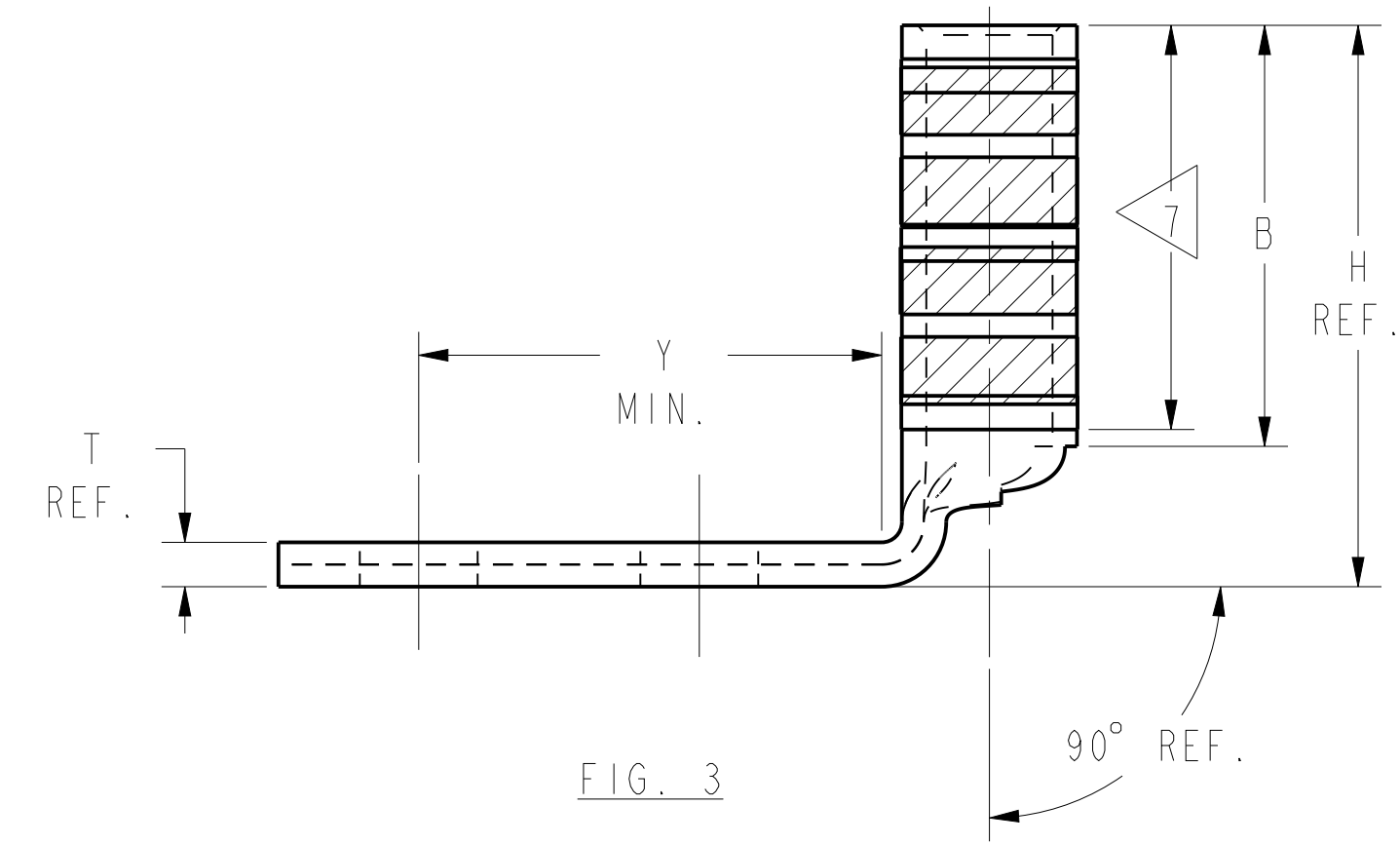
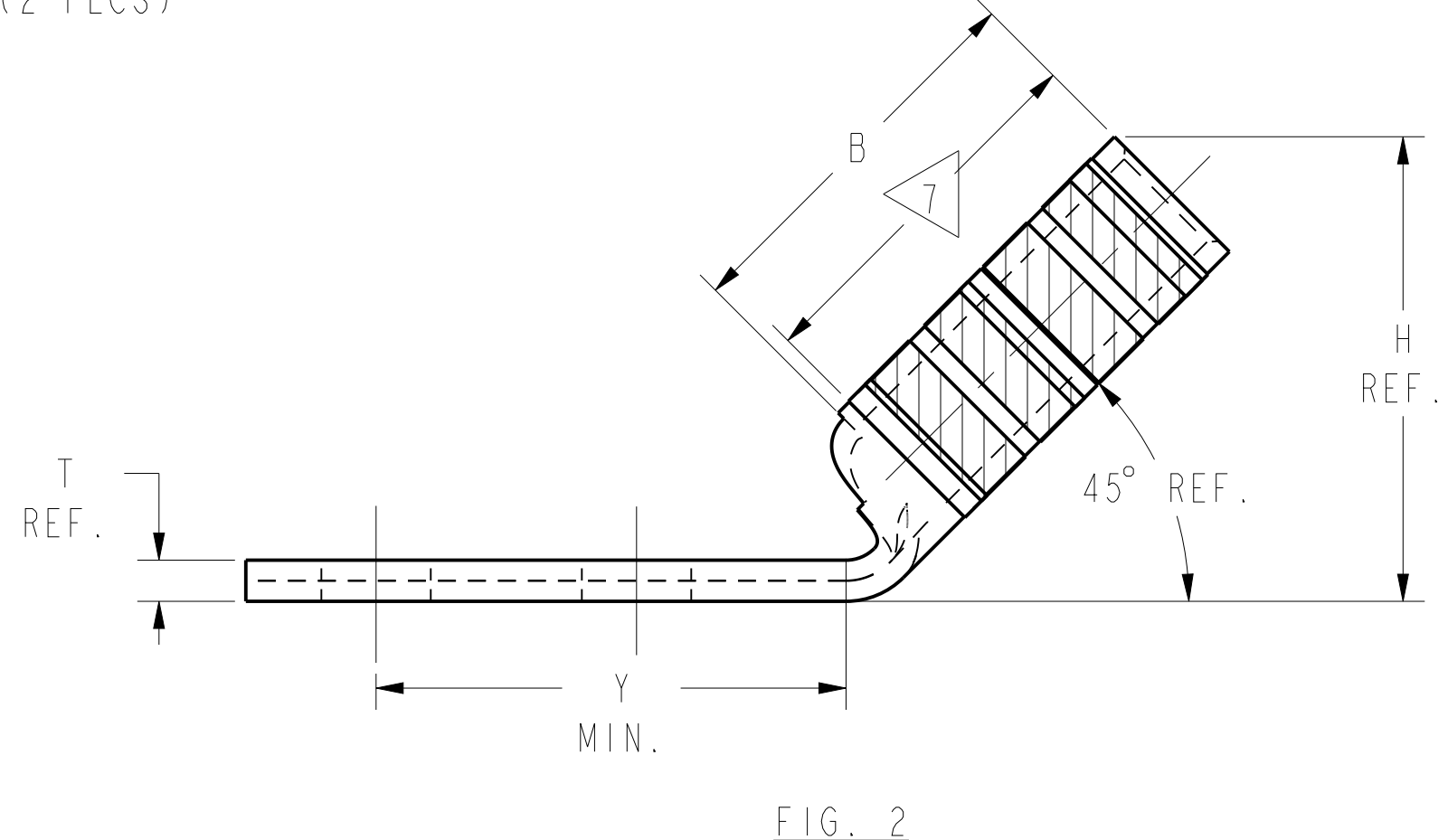
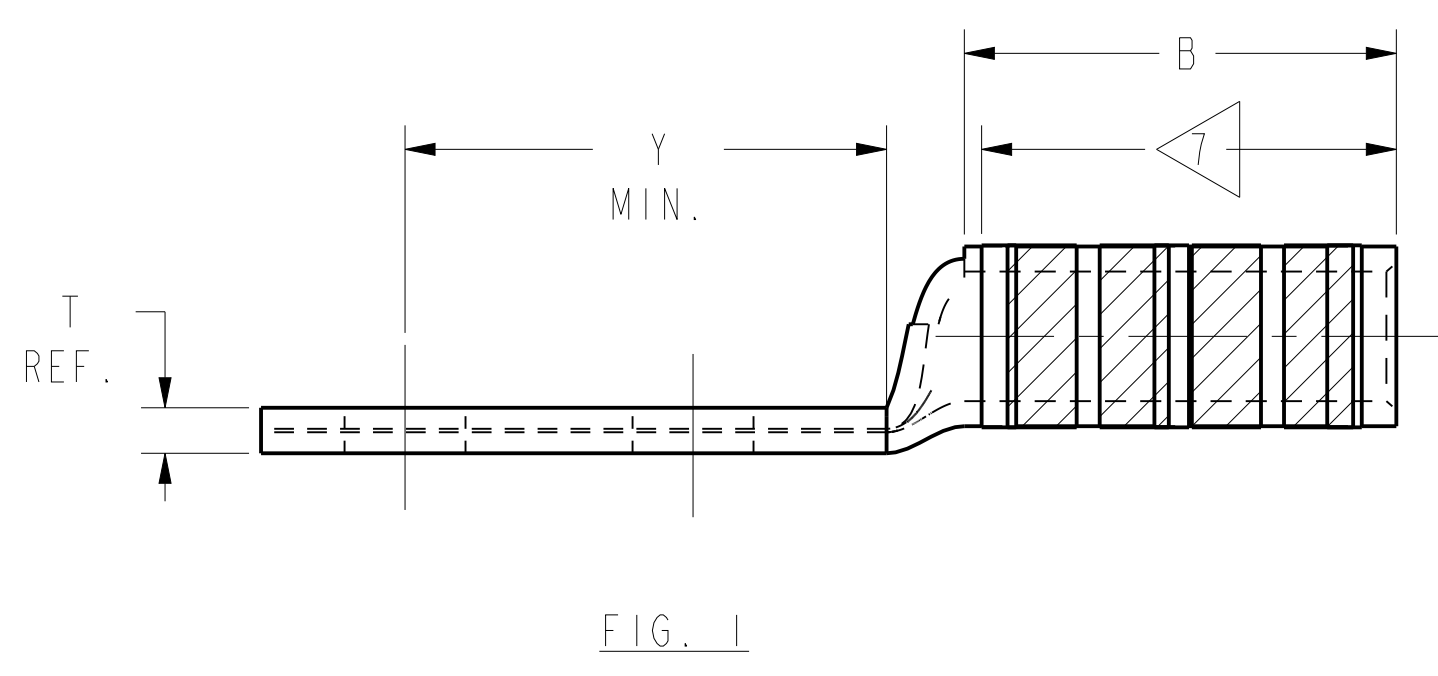
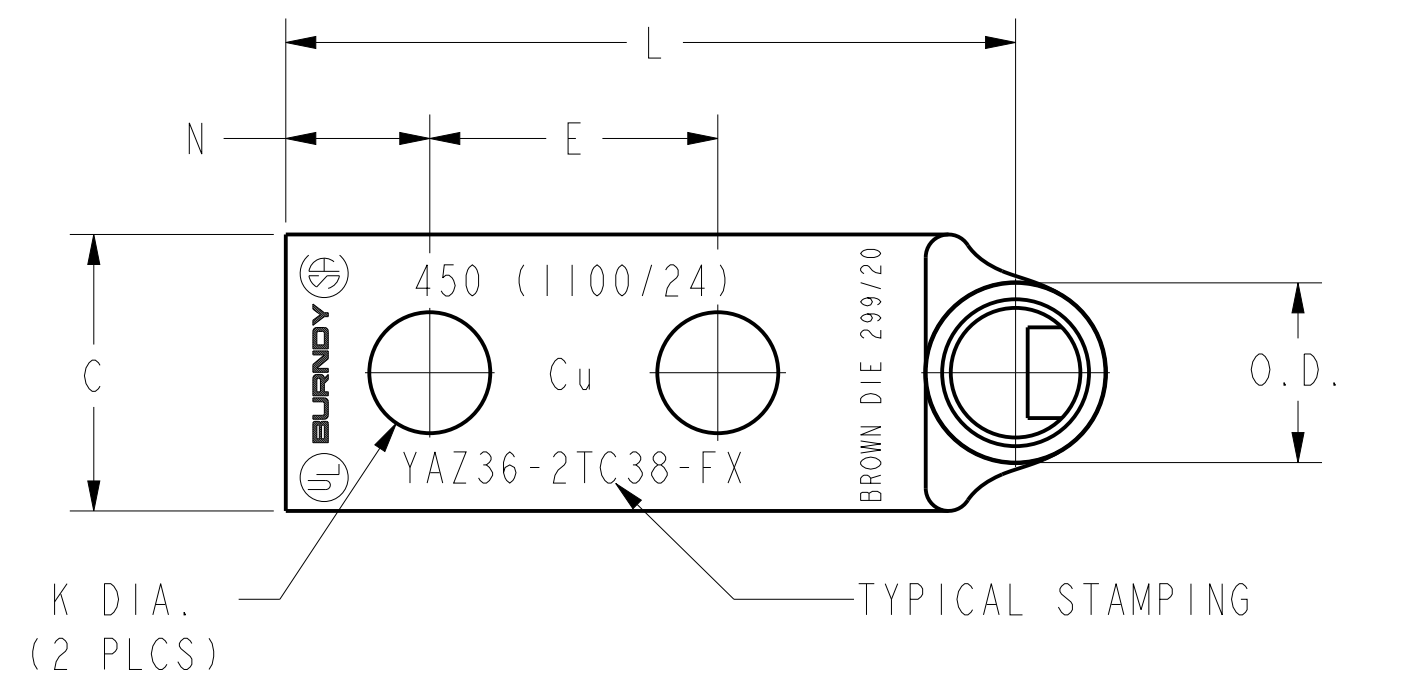
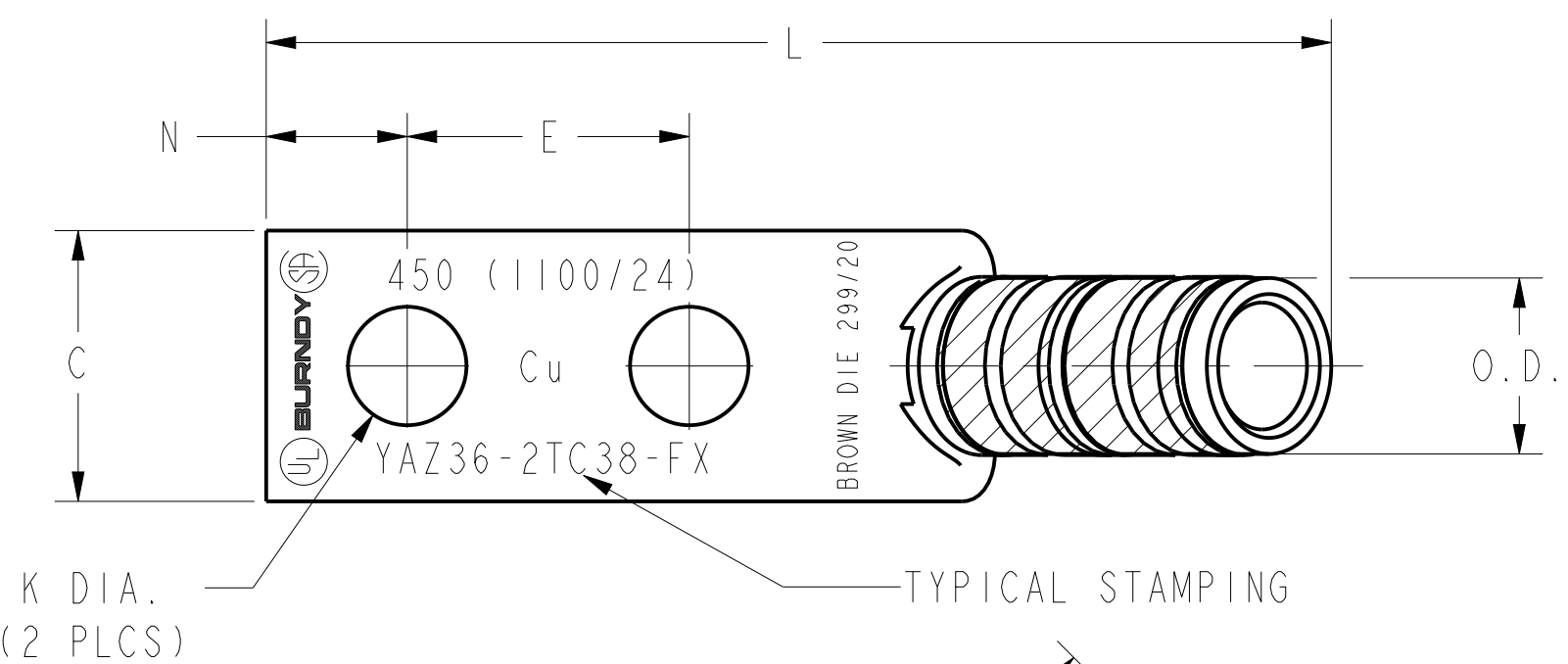
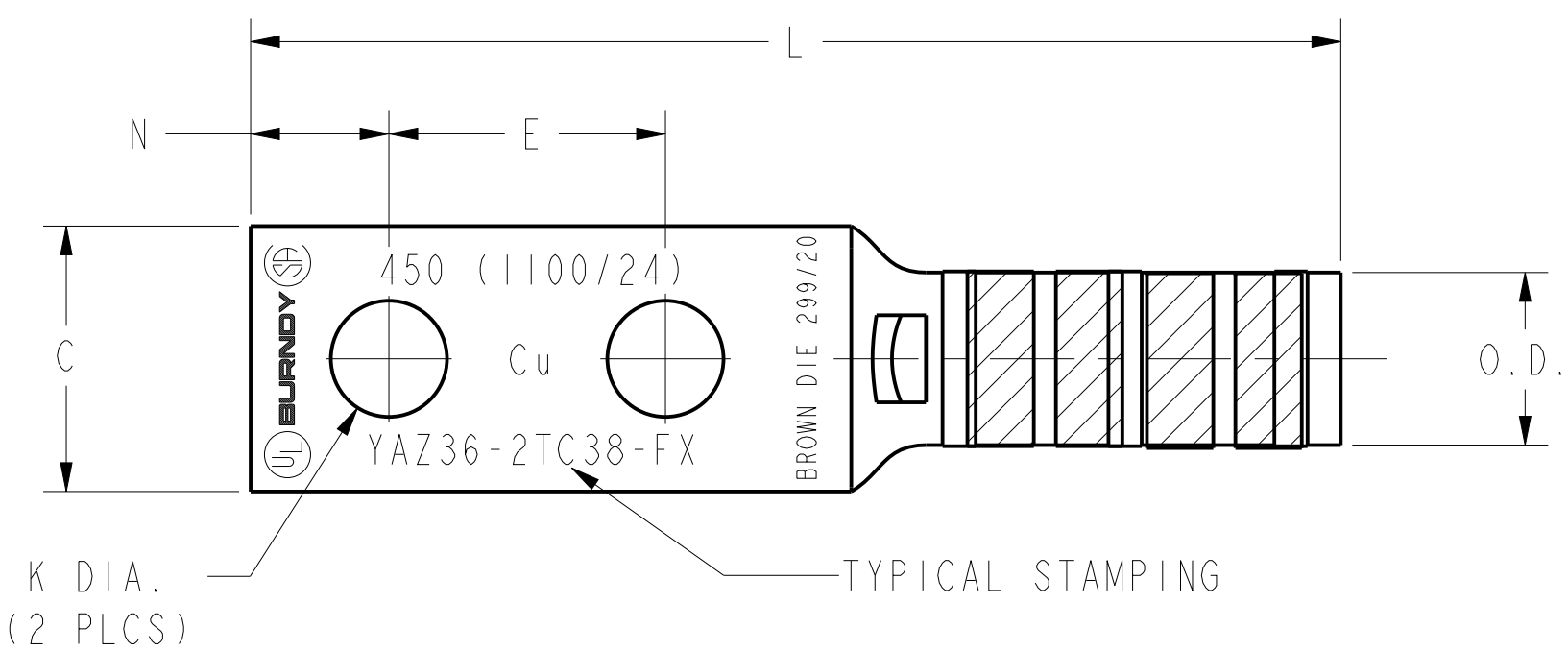

- NOTES:
- MATERIAL: COPPER TUBING.
 - FINISH: TIN PLATED.
 - CATALOG # PT6515 ADAPTOR IS REQUIRED TO USE "U" DIES IN Y45 SERIES TOOLS.
 - CATALOG # PUADP-1 ADAPTOR IS REQUIRED TO USE "U" DIES IN Y46 SERIES TOOLS.
 - PERMANENT DIE IN TOOLING.
 - DIMENSIONS IN BRACKETS [] ARE IN MILLIMETERS ROUNDED OFF TO THE NEAREST MILLIMETER, UNLESS OTHERWISE NOTED, AND ARE FOR REFERENCE ONLY.
 - ◁7 CRIMP (# OF CRIMPS PER TABLE) WITHIN THE LENGTH BETWEEN THE INK STAMPED CRIMPING AREA.

TO ORDER BURNDY@PRODUCTS CALL		HYLUG™ (TWO HOLE FLEX)	
UNITED STATES: 1-800-346-4175 (LONDONDERRY, NH)		ITEM NO: N/A	CAT. NO: YAZ36- (TABLE)
CANADA: 1-800-361-6975 (QUEBEC) 1-800-387-6487 (ALL OTHER PROVINCES)		DRAWN BY: B MICHAUD 8/25/99	CHECKER: D BOISVERT 8/26/99
FOR PRODUCT INFO: http://www.burndy.com		DSN APPVL: RR TEAM 9/28/99	MFG APPVL: --
		GA APPVL: J BRODEUR 10/6/99	MKT APPVL: R ROBICHEAU 10/5/99
		PROD FAM: --	SCALE: NTS
		PROJECT #: --	SIZE: D
		DOCUMENT TYPE: Sales	SE212273
		REL LEVEL: Released	SHEET 39 OF 48

REV: CREO_08/10/21