

HYGRID™ Type YGL-C Cross Connector

An irreversible compression ground grid cross connector which allows adjustment of the compression elements prior to installation. Only six connectors and four dies are required to install all combinations from #6 solid through 500 kcmil. UL467 Listed. Acceptable for direct burial in earth and concrete. Prefilled with PENETROX™ compound and strip sealed.



IEEE-837*



Catalog Number	B	BB	C	C-C	D	L	R
YGL2C2	0.75	0.75	1.09	1.09	0.31	2.50	0.31
YGL29C2			1.66	1.09	0.31		0.31
YGL29C29			1.66	1.66	0.50		0.50
YGL34C2			2.09	1.09	0.31		0.31
YGL34C29			2.09	1.66	0.50		0.50
YGL34C34	1.10	1.10	2.28	2.28	0.75		0.75

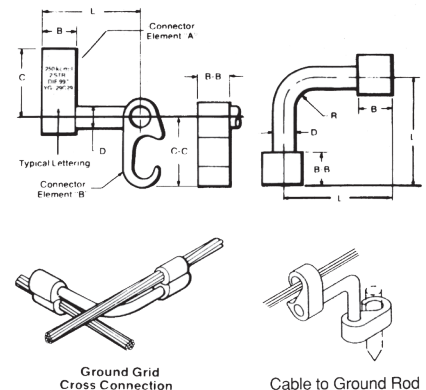

✓ UL96 Listed for Lightning Protection.

Catalog Number	Cable to Cable		Cable to Ground Rod ③		To Rebar
	Element "A"	Element "B"	Element "A"	Element "B"	Element "A"
YGL2C2	#6 Sol. (0.162) - #2 Str. (0.292) {59500} - {59500}	#6 Sol. (0.162) - #2 Str. (0.292) {59500} - {59500}	-	-	-
YGL29C2	#1 Str. (0.332) - 250 kcmil (0.575) {98500} - {131500}	#6 Sol. (0.162) - #2 Str. (0.292) {59500} - {59500}	1/2" - 5/8" Rod	#6 Sol. (0.162) - #2 Str. (0.292)	3/8" - 1/2"
YGL29C29	#2 Str. (0.292) - 250 kcmil (0.575) {65500} - {131500}	#2 Str. (0.292) - 250 kcmil (0.575) {65500} - {131500}	1/2" - 5/8" Rod	#2 Str. (0.292) - 250 kcmil (0.575)	#3 - 4 Rebar
YGL34C2	250 kcmil (0.575) - 500 kcmil (0.813)	#6 Sol. (0.162) - #2 Str. (0.292)	5/8" - 3/4" Rod	#6 Sol. (0.162) - #2 Str. (0.292)	5/8" - 3/4" #5 - 6 Rebar
YGL34C29		#2 Str. (0.292) - 250 kcmil (0.575)		#2 Str. (0.292) - 250 kcmil (0.575)	
YGL34C34		250 kcmil (0.575) - 500 kcmil (0.813)		250 kcmil (0.575) - 500 kcmil (0.813)	

Dimensions in brackets { } represent lightning protection conductors.

Catalog Number	Installation Tools, Die Set Catalog Number (Number of Crimps)					
	750, 35 Series		45 Series ①		46 Series ②	
	Element "A"	Element "B"	Element "A"	Element "B"	Element "A"	Element "B"
YGL2C2	U0 (1)	U0 (1)	U0 (1)	U0 (1)	U0 (1)	U0 (1)
YGL29C2	U997 (1)	U0 (1)	U997 (1)	U0 (1)	U997 (1)	U0 (1)
YGL29C29	U997 (1)	U997 (1)	U997 (1)	U997 (1)	U997 (1)	U997 (1)
YGL34C2 †	PU998 (1)	U0 (1)	S998 or PU998 (1)	U0 (1)	P998 or PU998 (1)	U0 (1)
YGL34C29 †	PU998 (1)	U997 (1)	S998 or PU998 (1)	U997 (1)	P998 or PU998 (1)	U997 (1)
YGL34C34 †	U1011 (3)	U1011 (3)	S1011 (3)	S1011 (3)	P1011 (3)	P1011 (3)

① 45 Series tools require PT6515 adapter to use "U" or "PU" die

② 46 Series tools require PUADP1 adapter to use "U" or "PU" die

† These connectors can only be installed using the 750, 45, or 46 Series tools with the recommended dies.

* Please contact Customer Service for applications requiring IEEE-837 2014.

NOTES:

- Before crimping, both connector elements can be turned on rod diameter "D" to any desired position.
- Clean rust and/or protective coatings from rebar prior to installation.

③ When attaching connector to ground rod, ground rod must be embossed with appropriate PRECRIMP die. For connectors that must meet IEEE 837 requirements, UPRECRIMP-type precrimp dies must be used for maximum clamping retention. No precrimp needed if using S1012, P1011 or U1011 die sets.

Ground Rod ③ Dia.	PRECRIMP Dies	
1/2"	UPRECRIMP12	U2CABT
5/8"	UPRECRIMP58	
3/4"	UPRECRIMP34	