



Part Winding Reduced Current SERIES MP420 Combined Manual and Automatic



Metron Fire Pump Controllers conform to the latest requirements of National Fire Protection Association's Standard for Centrifugal Fire Pumps as adopted by Underwriters Laboratories and Factory Mutual. They are short circuit withstand rated and listed by Underwriters Laboratories and approved by Factory Mutual Research Corporation.

Sizes range from 15 to 700 horsepower, 200 to 600 volts (480 volts max. when supplied with transfer switch), 50 or 60 Hz. These controllers are for use on reduced voltage type installations.

Only the highest quality components, all UL listed or UL recognized, are used throughout to assure the best possible reliability. The cabinet is fabricated of heavy gauge reinforced steel with drip-proof hood. All field wiring and service connections may be made from the front, allowing the controller to be mounted flush against a wall.



Controllers are completely wired, assembled, and tested at the factory before shipment and ready for immediate installation.





Standard and Optional Features



Standard Features

- » NEMA Type 2 drip proof metal freestanding enclosure
- » Operator Interface Device (OID) with 4 lines by 20 character display with large character backlit Liquid Crystal Display (LCD) capable of being read in both direct sunlight or dark lighting conditions
- » 10 pushbuttons for easy screen navigation, LED lamp test, alarm reset, controller test and horn silencing
- » Removable labels to allow for easy field language changes
- » All controller settings are programmable through the OID. All features are enabled or disabled through the OID, no jumpers or external wires are needed allowing easy field modification
- » The system status data is displayed on the OID. The displayed items include: System pressure, Phase to Phase (AB, BC, AC) voltage, Phase current (A, B, C), Current time and date, System Events and Notifications such as Remote Start, Local Start etc., Number of starts, Total motor run hours, Time remaining on sequential motor start and motor stop timers, Status of automatic stop setting.
- » Auxiliary alarm functions displayed on the OID LCD screen
- » Audible horn with silence feature for silenceable alarms
- » Lamp test feature
- » Foreign languages selectable through the OID
- » Microprocessor based logic with real time/date clock capable of running a minimum of 14 days without AC power connected to controller
- » SD Memory card used to record pressure log, event and log, and auxiliary user programs. Pressure log is stored in separate comma delimited ASCII text files with each file containing data for one day. The SD card is removable and can be read by any PC equipped with an SD card reader.
- » Input and output status LED's provide visual indication of each discrete input's or output's on/off status
- » One RS485 Serial Port
- » MODBUS Communication Protocol via RS485 port
- » Service Entrance Rated

Standard Auxiliary Alarms

The controller includes as standard six (6) discrete auxiliary inputs, nine (9) form 'C' auxiliary relay outputs. These auxiliary inputs and outputs are in addition to those mandated by NFPA 20. All auxiliary inputs, outputs, and OID Display can be field programmed through the OID.

Nine (9) of the following auxiliary alarms can be programmed and recorded in the event/alarm logs and annunciated on the OID display screen and/or output relay contact(s). These alarm conditions include:

LOW PUMP ROOM TEMP	LOW PURGE PRESSURE
RESERVOIR LOW	LOW GEAR OIL PRESSURE
RESERVOIR EMPTY	HIGH GEAR OIL TEMP
RESERVOIR HIGH	GAS DETECTION
FLOW METER ON	HIGH VIBRATION
RELIEF VALVE OPEN	EMERGENCY POWER ON
LOW SUCTION PRESSURE	PUMP ROOM DOOR OPEN
LOW FIREWATER PRESSURE	
HIGH PUMP ROOM TEMPERATURE	





Standard and Optional Features

Data Logging

The controller includes two (2) separate data logs for storing system data that is readable through the OID or copied to a computer equipped with an SD card reader. The 2 data logs are as follows:

Pressure Log: The pressure log provides a continuous pressure record for 30 days. The pressure log samples shall be time and date stamped and stored in permanent non-volatile SD memory card. The pressure log can be searched by each sample, by minute, or by hour through the OID.

Event Log: The event log will store up to 300 of the most current events. These events can include, but is not limited to, any of the following events/alarms:

- PUMP RUNNING
- POWER AVAILABLE
- PHASE REVERSAL
- MOTOR OVERLOAD
- REMOTE START
- LOCAL START
- PUMP ON DEMAND
- SYSTEM FAULT
- PRESSURE TRANSDUCER FAULT
- PUMP FAILED TO START
- LOW INTAKE SHUTDOWN ALARM
- SUPERVISORY POWER FAILURE
- LOW PRESSURE
- AUTO WEEKLY TEST START
- UNDER FREQUENCY
- OVER FREQUENCY
- LOW ZONE/ HIGH ZONE CONTACTS
- HIGH DISCHARGE PRESSURE
- NO LOAD CONDITION

Model Number Designation

Example: MP420-H-75-480C

MP420 -- Model Type

- **X** -- Option Designation(s)

- **XXX** -- Horsepower Rating: 15-700

- **XXX** -- Voltage Rating: 200-600 VAC

X -- Withstand Rating: B - 22,000 (@575 VAC) 50,000 (200-480 VAC)
C - 100,000 (200-480 VAC)

Information required with order: 1) Model Type 2) Motor Horsepower 3) Line Voltage, phase and frequency 4) Options, if any (complete description)

Options

Option H: Space Heater

If the ambient atmosphere is especially damp, a space heater rated at 100 watts may be supplied to reduce moisture in the cabinet. A thermostat is supplied as standard with this option. A humidistat may be substituted if specified.

Option W: Omit Legs

For systems where the controller is mounted on a common skid with the pump and motor, the legs of the controller may be omitted, 3" (76.2mm) channels or wall mounting brackets can be supplied. If specified, lifting eyes may also be supplied.

Enclosure

The following NEMA type enclosures are also available: 3R, 4, 4X (Painted Cold Rolled Steel), 4X (304 or 316 Stainless Steel), and 12.

Consult factory for additional options.

Standard Withstand Ratings

VOLTS	HP -- RMS SYMMETRICAL
200-208	15-150 -- 100kA
220-240	15-200 -- 100kA
380-415	15-300 -- 100kA
460-480	15-400 -- 100kA
200-208	200-250 -- 50kA
220-240	250-300 -- 50kA
380-415	350-350 -- 50kA
460-480	500-600 -- 50kA
550-600	15-400 -- 22kA





Specifications

General Controller Description

The Fire Pump Controller shall be factory assembled, wired and tested as a unit and shall conform to all requirements of the latest edition of NFPA 20 and by Third Party Listed by Underwriters Laboratories (UL) and Approved by Factory Mutual (FM). The controller shall be available for 208, 230, 380-415, 480, or 575-600 volt three phase power.

Controller Equipment Features

The controller shall include the following standard features:

- » NEMA Type 2 drip proof metal freestanding enclosure
- » Operator Interface Device (OID) with 4 lines by 20 character display with large character backlit LCD capable of being read in both direct sunlight or dark lighting conditions
- » 10 pushbuttons for easy screen navigation, system test, lamp test, alarm reset, and horn silencing
- » Multicolored LED's for alarm and mode annunciation
- » LEDs shall be labeled with removable labels to allow for easy field modification of language changes
- » All controller settings shall be programmable through the OID and shall be protected by two password levels
- » All features shall be enabled or disabled through the OID, no jumpers or external wires shall be needed or allowed to activate or deactivate a feature
- » The system status data shall be displayed on the OID. The displayed items shall include: System pressure, Phase to Phase (AB, BC, AC) voltage, Phase current (A, B, C), System Events and Notifications, Current time and date, Number of starts, Total motor run hours, Displayed countdown timers for: Sequential motor start and motor stop, Status of Automatic Stop Setting.
- » Audible horn with silence feature for silencable alarms
- » Lamp test feature
- » Foreign languages selectable through the OID
- » One RS485 Serial Port
- » MODBUS Communication Protocol via RS485 port
- » All wiring terminals on PCB's shall be removable type
- » Service Entrance Rated

- » Microprocessor based logic with real time/ date clock capable of running a minimum of 14 days without AC power connected to controller and non-volatile flash memory to permanently store the continuous pressure log, event log, alarm log and all user changeable set points and system data. Battery backup of any kind not allowed.
- » Input and output status LED's to provide visual indication of each discrete input's or output's on/off status

Auxiliary Alarms

As standard the controller shall include 6 discrete auxiliary inputs, 9 form 'C' auxiliary relay outputs. These auxiliary inputs and outputs are in addition to those mandated by NFPA 20. All auxiliary inputs, outputs, and OID screens shall be field programmable through the OID. This permits a multitude of customizable controller configurations to meet each installations unique needs without adding cost to the controller. The use of jumpers, soldering, or other external components are not allowed.

The user can select any 9 of the following auxiliary alarms that can be programmed and recorded in the event log and annunciated with an OID screen and output relay contact for conditions such as but not limited to:

- LOW PUMP ROOM TEMP
- RESERVOIR LOW
- RESERVOIR EMPTY
- RESERVOIR HIGH
- FLOW METER ON
- RELIEF VALVE OPEN
- LOW SUCTION PRESSURE
- HIGH PUMP ROOM TEMPERATURE
- LOW FIREWATER PRESSURE
- LOW PURGE PRESSURE
- LOW GEAR OIL PRESSURE
- HIGH GEAR OIL TEMPERATURE
- GAS DETECTION
- HIGH VIBRATION
- EMERGENCY POWER ON
- PUMP ROOM DOOR OPEN

Data Logging

The controller shall have separate data logs for storing system data that is readable through the OID.

Pressure Log: The controller shall have a Pressure log with continuous pressure recording of 30 days of data. The pressure log samples shall be time and date stamped and stored on a removable SD card memory. The pressure log shall be searchable by each sample, by minute, or by hour. Each days entries shall be stored in a separate file on the SD card. SD memory shall be readable by any PC equipped with an SD memory card reader.

Event Log: The event log shall be capable of storing no less than 3000 events. These events shall include, but is not limited to, any of the following events/alarms:

- PUMP RUNNING
- POWER AVAILABLE
- PHASE REVERSAL
- MOTOR OVERLOAD
- REMOTE START
- LOCAL START
- PUMP ON DEMAND
- SYSTEM FAULT
- PRESSURE TRANSDUCER FAULT
- PUMP FAILED TO START
- LOW INTAKE SHUTDOWN ALARM
- SUPERVISORY POWER FAILURE
- LOW PRESSURE
- AUTO WEEKLY TEST START
- UNDER FREQUENCY
- OVER FREQUENCY
- LOW ZONE / HIGH ZONE CONTACTS
- HIGH DISCHARGE PRESSURE
- NO LOAD CONDITION

Each event or alarm recorded in the event log shall have the following data recorded with the event/alarm:

- Time and Date of Event or Alarm
- System Pressure
- Descriptive Text Message of the Event/ Alarm
- Motor Running Status
- Phase to Phase Volts
- Phase Amps

The internal logic of the controller shall be capable of operation in a temperature range of 4.4°C to 50°C and high, non-condensing, humidity levels.

Controllers shall be manufactured by Metron - A Division of Hubbell Industrial Controls, Inc.

www.metroninc.com



Hubbell Industrial Controls, Inc. • 4301 Cheyenne Dr., Archdale, NC 27263
PH: 336-434-2800 • FAX: 336-434-2809 • Email: salesmail@metroninc.com





Automatic Transfer Switches

SERIES MTS For Electric Motor Driven Fire Pumps



MP435 Fire Pump Controller with Automatic Transfer Switch

Metron MTS Automatic Transfer Switch provides operation of electric fire pump motors from an alternate source of power when the normal source fails. They may be used with any Metron electric fire pump controller— Across the Line, Primary Resistance, Part Winding, Wye-Delta, Auto Transformer or Solid State Reduced Voltage Types. These transfer switches are an integral part of the fire pump controller. They are factory assembled, shipped and installed as a part of the controller.

The combination fire pump controller/transfer switch is listed by Underwriters Laboratories, Factory Mutual, and meets all the latest requirements of NFPA's Standard for Installation of Centrifugal Fire Pumps.

The MTS Automatic Transfer Switch is a mechanically held double throw switch with a fast acting drive mechanism. Operating coils are momentarily energized from the source to which the load is being transferred. The switch is interlocked electrically and mechanically to prevent both services from feeding the load at the same time. The transfer switch is capable of manual (non-electrical) operation.

Under voltage sensing devices are supplied which monitor each phase of normal service. When the voltage of any phase falls below the pre-set level the transfer switch automatically transfers to the alternate source. Voltage and frequency sensing devices are provided to monitor one phase of the alternate source and will inhibit transfer to the alternate source until adequate voltage and frequency are available.

The transfer switch provides a special circuit that de-energizes the motor control circuit five (5) second prior to transfer in either direction to prevent high current transients due to an out-of-phase condition between the motor and the source to which it is being connected.

A contact is provided to actuate the engine starting circuit when normal source fails. To prevent false starts, a time delay (factory set at 1/2 to 3 seconds) is provided between normal source failure and actuation of the engine start contact.

An isolation switch ahead of the alternate source input terminals of the transfer switch is provided. When the switch is opened, auxiliary contacts in the generator start circuit prevent starting if commanded to by the transfer switch. An additional auxiliary contact on the isolation switch is provided for remote annunciation of isolation switch position.

An adjustable time delay (0-30 min.) prevents restoration to normal service for a preset period of time to assure normal line stabilization. An auxiliary N.O. contact is provided for remote annunciation of transfer to emergency. This contact is operated by the transfer mechanism as a direct indication of switch position. Pilot lights for indication of Switch in Normal position, Switch in Emergency position, and Emergency Isolation Switch in Off. Audible indication of Emergency Isolation Switch in Off is also included.

A test switch is also provided which simulates loss of normal power so that the transfer switch operation can be checked without interrupting normal service to the fire pump controller.





Specifications

Controller Equipment Features

The controller shall include the following standard features:

- » NEMA Type 2 drip proof metal freestanding enclosure
- » Operator Interface Device (OID) with 4 lines by 20 character display with large character backlit LCD capable of being read in both direct sunlight or dark lighting conditions
- » 10 pushbuttons for easy screen navigation, system test, lamp test, alarm reset, and horn silencing
- » Multicolored LED's for alarm and mode annunciation
- » LEDs shall be labeled with removable labels to allow for easy field modification of language changes
- » All controller settings shall be programmable through the OID and shall be protected by two password levels
- » All features shall be enabled or disabled through the OID, no jumpers or external wires shall be needed or allowed to activate or deactivate a feature
- » The system status data shall be displayed on the OID. The displayed items shall include: System pressure, Phase to Phase (AB, BC, AC) voltage, Phase current (A, B, C), System Events and Notifications, Current time and date, Number of starts, Total motor run hours, Displayed countdown timers for: Sequential motor start and motor stop, Status of Automatic Stop Setting.
- » Audible horn with silence feature for silencable alarms
- » Lamp test feature
- » Foreign languages selectable through the OID
- » One RS485 Serial Port
- » MODBUS Communication Protocol via RS485 port
- » All wiring terminals on PCB's shall be removable type
- » Service Entrance Rated

- » Microprocessor based logic with real time/date clock capable of running a minimum of 14 days without AC power connected to controller and non-volatile flash memory to permanently store the continuous pressure log, event log, alarm log and all user changeable set points and system data. Battery backup of any kind not allowed.
- » Input and output status LED's to provide visual indication of each discrete input's or output's on/off status

Auxiliary Alarms

As standard the controller shall include 6 discrete auxiliary inputs, 9 form 'C' auxiliary relay outputs. These auxiliary inputs and outputs are in addition to those mandated by NFPA 20. All auxiliary inputs, outputs, and OID screens shall be field programmable through the OID. This permits a multitude of customizable controller configurations to meet each installations unique needs without adding cost to the controller. The use of jumpers, soldering, or other external components are not allowed.

The user can select any 9 of the following auxiliary alarms that can be programmed and recorded in the event log and annunciated with an OID screen and output relay contact for conditions such as but not limited to:

- LOW PUMP ROOM TEMP
- RESERVOIR LOW
- RESERVOIR EMPTY
- RESERVOIR HIGH
- FLOW METER ON
- RELIEF VALVE OPEN
- LOW SUCTION PRESSURE
- HIGH PUMP ROOM TEMPERATURE
- LOW FIREWATER PRESSURE
- LOW PURGE PRESSURE
- LOW GEAR OIL PRESSURE
- HIGH GEAR OIL TEMPERATURE
- GAS DETECTION
- HIGH VIBRATION
- EMERGENCY POWER ON
- PUMP ROOM DOOR OPEN

Data Logging

The controller shall have separate data logs for storing system data that is readable through the OID.

Pressure Log: The controller shall have a Pressure log with continuous pressure recording of 30 days of data. The pressure log samples shall be time and date stamped and stored on a removable SD card memory. The pressure log shall be searchable by each sample, by minute, or by hour. Each days entries shall be stored in a separate file on the SD card. SD memory shall be readable by any PC equipped with an SD memory card reader.

Event Log: The event log shall be capable of storing no less than 3000 events. These events shall include, but is not limited to, any of the following events/alarms:

- PUMP RUNNING
- POWER AVAILABLE
- PHASE REVERSAL
- MOTOR OVERLOAD
- REMOTE START
- LOCAL START
- PUMP ON DEMAND
- SYSTEM FAULT
- PRESSURE TRANSDUCER FAULT
- PUMP FAILED TO START
- LOW INTAKE SHUTDOWN ALARM
- SUPERVISORY POWER FAILURE
- LOW PRESSURE
- AUTO WEEKLY TEST START
- UNDER FREQUENCY
- OVER FREQUENCY
- LOW ZONE / HIGH ZONE CONTACTS
- HIGH DISCHARGE PRESSURE
- NO LOAD CONDITION

Each event or alarm recorded in the event log shall have the following data recorded with the event/alarm:

- Time and Date of Event or Alarm
- System Pressure
- Descriptive Text Message of the Event/ Alarm
- Motor Running Status
- Phase to Phase Volts
- Phase Amps

The internal logic of the controller shall be capable of operation in a temperature range of 4.4°C to 50°C and high, non-condensing, humidity levels.

Controllers shall be manufactured by Metron - A Division of Hubbell Industrial Controls, Inc.

www.metroninc.com



Hubbell Industrial Controls, Inc. • 4301 Cheyenne Dr., Archdale, NC 27263
PH: 336-434-2800 • FAX: 336-434-2809 • Email: salesmail@metroninc.com



ISOLATION SWITCH/
CIRCUIT BREAKER
OPERATOR
NORMAL POWER

OPERATOR
EMERGENCY POWER

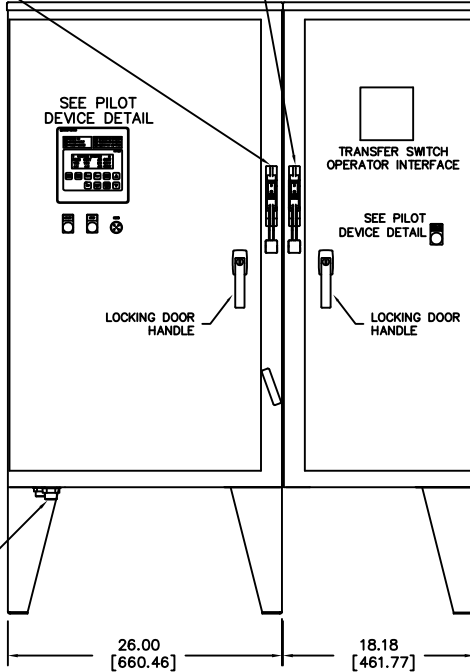

FRONT VIEW

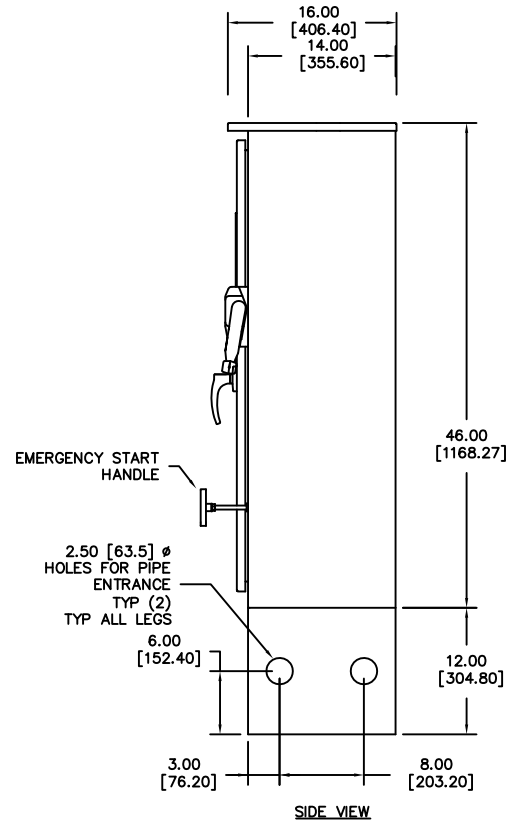

SIDE VIEW

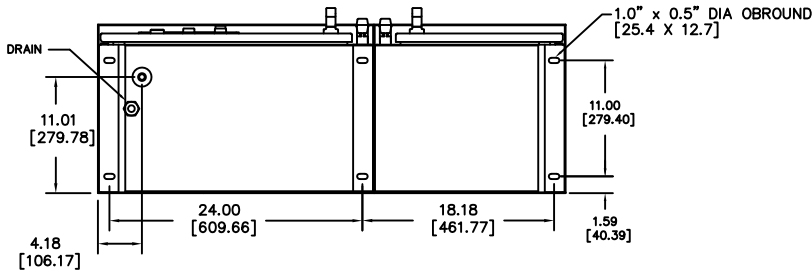

BOTTOM VIEW

PILOT DEVICE DETAIL

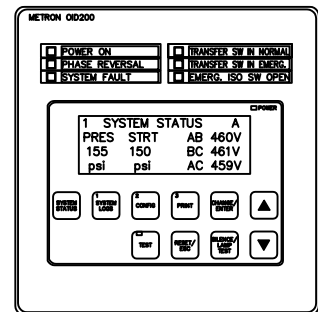

VOLTAGE	HORSEPOWER
200V	15-60 HP.
208V	15-75 HP.
230V	15-75 HP.
380V	15-125 HP.
460V	15-150 HP.

NOTES:
1. ALL DIMENSIONS IN INCHES AND MILLIMETERS ([]).

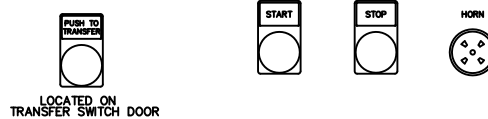

LOCATED ON
TRANSFER SWITCH DOOR

NEMA 2 ENCLOSURE.

DRAWN M.K.	3-20-05	METRON A Division of: Hubbell ICD, Inc. 4301 Cheyenne Dr., Archdale, NC 27263	
	CHECK R.L.		3-25-05
	APPD J.B.		3-25-05
ENCLOSURE DIMENSIONS MODEL MP420 WITH MTS 44"x46" CABINET ELECTRIC FIRE PUMP CONTROLLER		OPTIONS: CD33991F SCALE N.T.S. SHEET 1 OF 1	

ALT. SOURCE
POWER OPERATOR

PRESSURE
CONNECTION
1/2" N.P.T.,
FEMALE THREAD
DRAIN

5.0
[127]

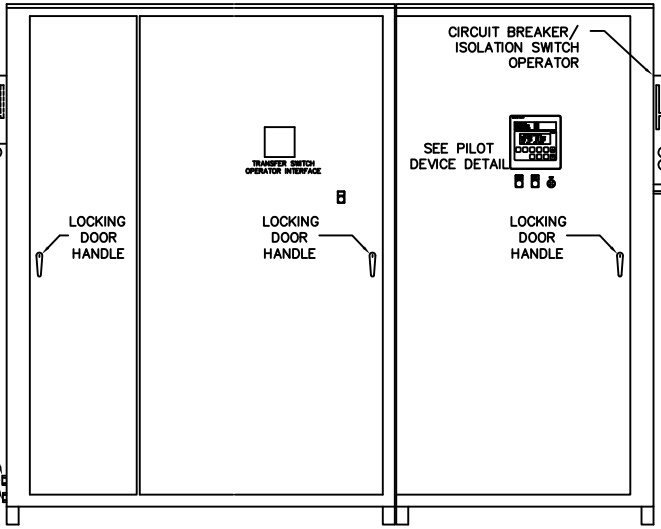

FRONT VIEW

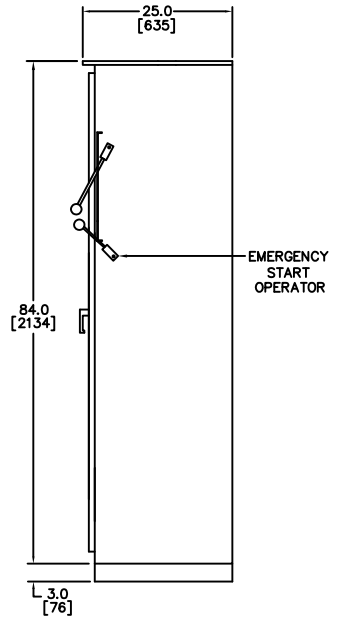

SIDE VIEW

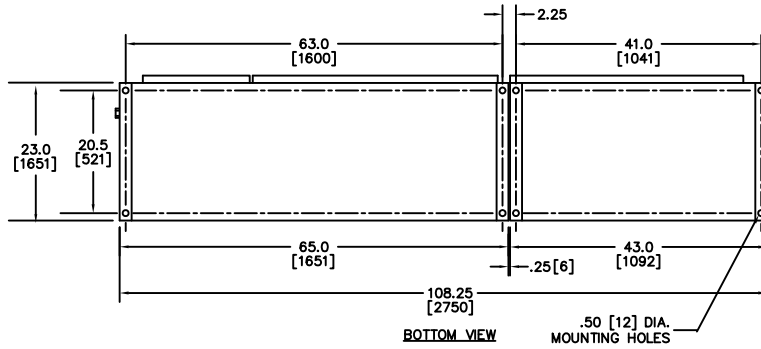

BOTTOM VIEW

PILOT DEVICE DETAIL

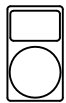
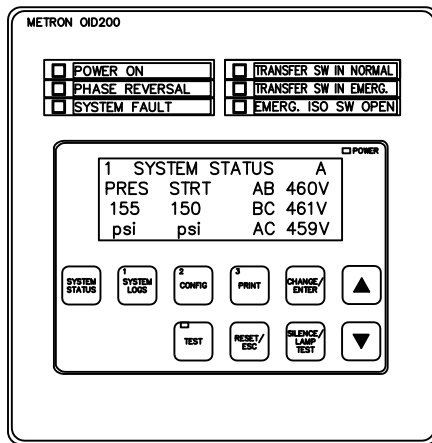

PILOT DEVICE DETAIL
TRANSFER SWITCH CABINET



NEMA 2 ENCLOSURE.

DRAWN	SR	2-10-98	METRON A Division of: Hubbell ICD, Inc. <small>4301 Cheyenne Dr., Archdale, NC 27263</small>
CHECK	K.H.	2-21-98	
APPD	X.A.	2-21-98	
ENCLOSURE DIMENSIONS MODEL MP420 WITH TRANSFER SWITCH 108.25" CABINET, 23" DEEP ELECTRIC FIRE PUMP CONTROLLER			OPTIONS: CD35012
SCALE		N.T.S.	SHEET 1 OF 1

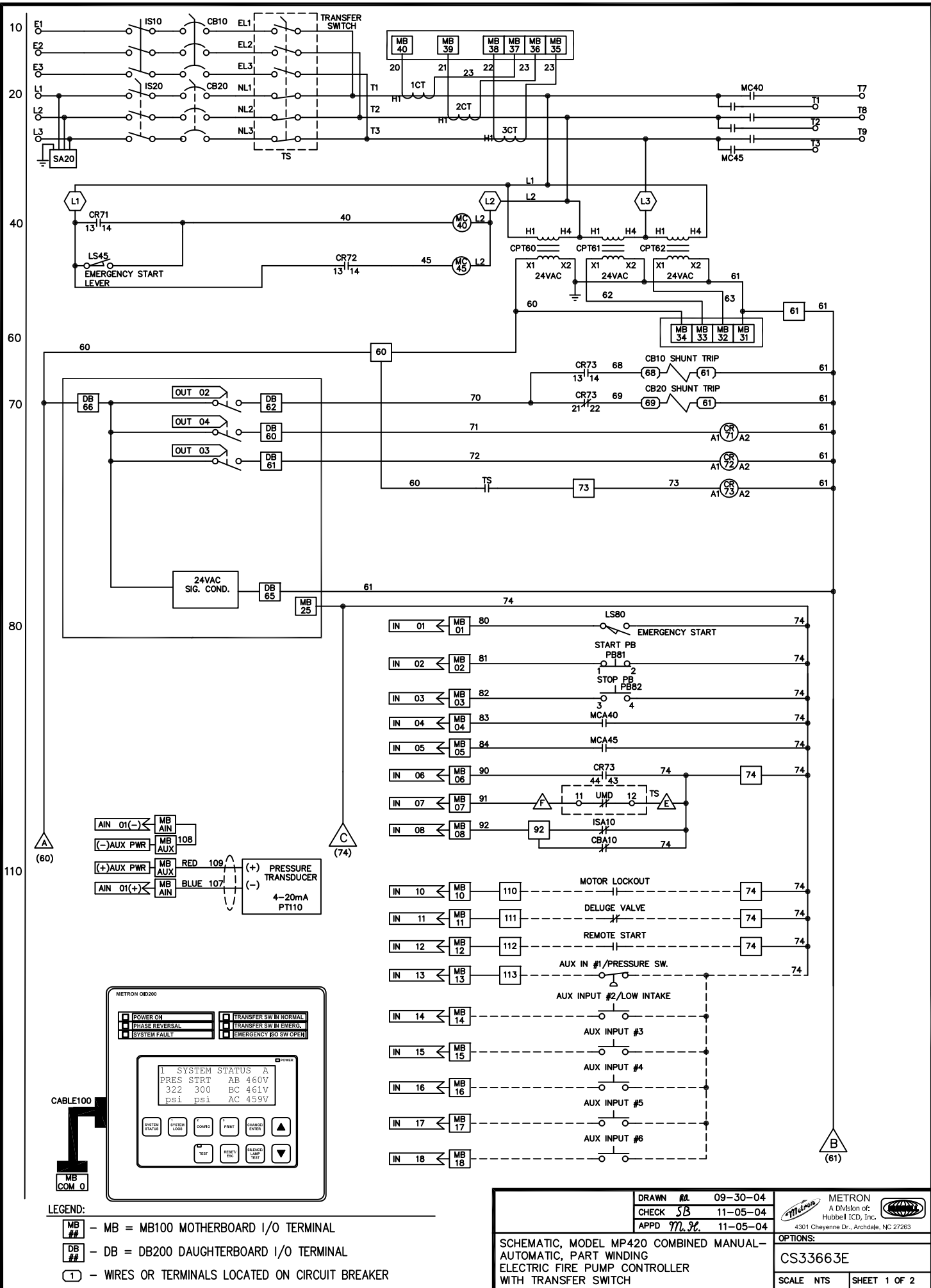

- LEGEND:**
- MB ## - MB = MB100 MOTHERBOARD I/O TERMINAL
 - DB ## - DB = DB200 DAUGHTERBOARD I/O TERMINAL
 - (1) - WIRES OR TERMINALS LOCATED ON CIRCUIT BREAKER

DRAWN <i>RA</i>	09-30-04	 METRON A Division of Hubbell ICD, Inc. <small>4301 Cheyenne Dr., Archdale, NC 27263</small>
CHECK <i>SB</i>	11-05-04	
APPD <i>M.L.</i>	11-05-04	
SCHMATIC, MODEL MP420 COMBINED MANUAL-AUTOMATIC, PART WINDING ELECTRIC FIRE PUMP CONTROLLER WITH TRANSFER SWITCH		
SCALE NTS		OPTIONS: CS33663E SHEET 1 OF 2

200
230
240
250
260
270

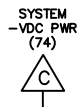
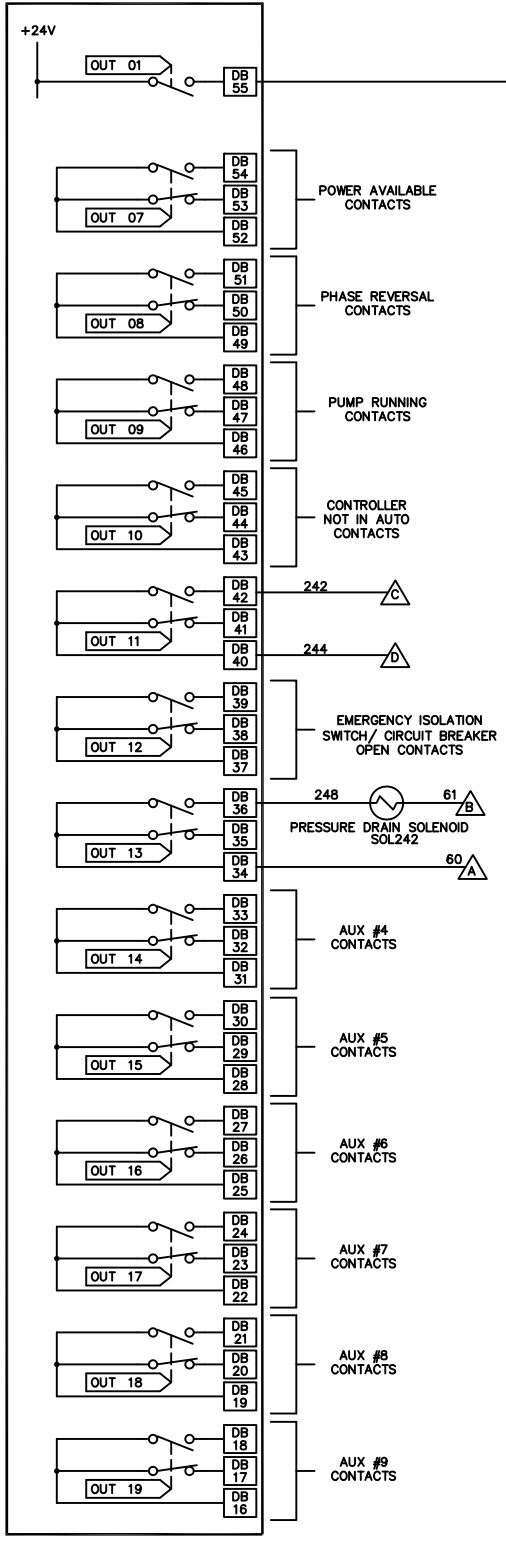

	DRAWN <i>RL</i> 09-30-04	 METRON A Division of: Hubbell ICD, Inc. <small>4301 Cheyenne Dr., Archdale, NC 27263</small>
	CHECK <i>SB</i> 11-05-04	
	APPD <i>M.S.L.</i> 11-05-04	
SCHEMATIC, MODEL MP420 COMBINED MANUAL-AUTOMATIC, PART WINDING ELECTRIC FIRE PUMP CONTROLLER WITH TRANSFER SWITCH		OPTIONS: CS33663E
SCALE NTS		SHEET 2 OF 2

COMPONENT	FUNCTION	LOCATION	CONTACTS
A3-1	LIMIT SWITCH EMERGENCY POS.		14
A4-1	LIMIT SWITCH NORMAL POS.		35
BR	BRIDGE RECTIFIER		15
CNE	TRANSFER SOLENOID	16	1,4,7
CCN	CONTROL COIL RELAY (NORM)	27	12,18
CCE	CONTROL COIL RELAY (EMERG)	27	12,18
DS	ON-OFF SELECTOR SWITCH		38
P	ENG. START RELAY		18,21
R1	MOTOR DISC NORMAL	15	28
R2	MOTOR DISC EMERGENCY	28	30
RT	TIMER T BYPASS RELAY	27	13
SCE	LIMIT SWITCH EMERGENCY		12
SCN	LIMIT SWITCH NORMAL		12
XE1	CONTROL TRANS., EMERGENCY	23	
XN1,2	CONTROL TRANS., NORMAL	23	

NOTES:

- EMERGENCY ISOLATION SWITCH AUXILIARY CONTACTS SHOWN WITH ISOLATION SWITCH IN OPEN POSITION.
- CONTACTS R1 OR R2 OPEN 5 SECONDS PRIOR TO TRANSFER IN EITHER DIRECTION.
- CONTACT 25-25B "RETURN INHIBIT" CAN BE USED TO PREVENT RETRANSFER TO NORMAL UNTIL CONTACT CLOSES.
- DEVICE WITHIN DASHED AREAS ARE LOCATED ACCORDING TO THE FOLLOWING DESIGNATIONS:
C-CONTROL PANEL, F-CABINET FRONT, P-POWER PANEL
- SEE FIRE PUMP CONTROLLER CONTROL SCHEMATIC IN RIGHT DOOR.
- △ DENOTES MATCH POINT ON FIRE PUMP CONTROLLER SCHEMATIC LOCATED IN RIGHT DOOR.
- ISOLATION SWITCH NOT USED ON MODEL MP30 CONTROLLERS

10ISA ISOLATION SWITCH AUXILIARY (SEE NOTE 7) 19,20
10CBA CIRCUIT BREAKER AUXILIARY 19,20

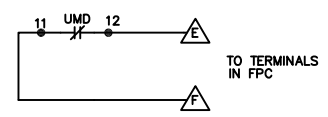
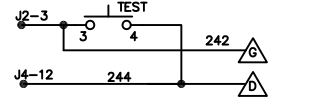
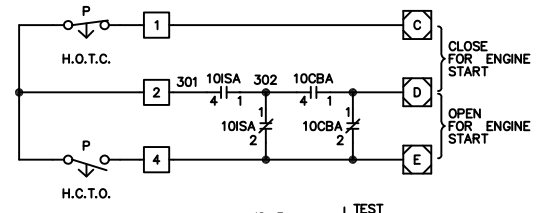
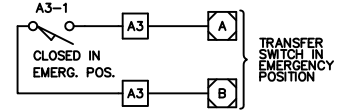
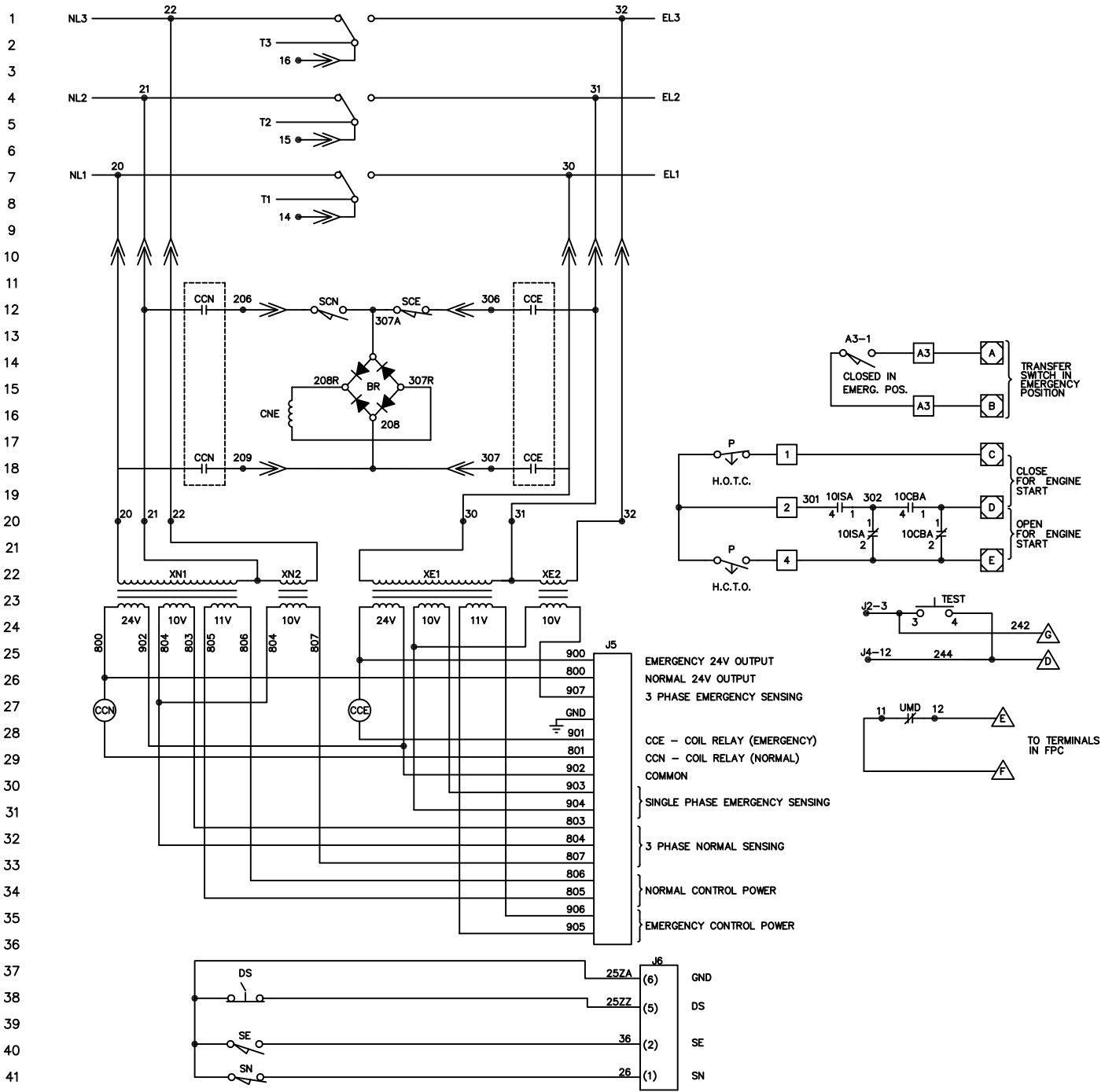

J5
 900 EMERGENCY 24V OUTPUT
 800 NORMAL 24V OUTPUT
 907 3 PHASE EMERGENCY SENSING
 GND
 901
 801 CCE - COIL RELAY (EMERGENCY)
 902 CCN - COIL RELAY (NORMAL)
 903 COMMON
 904 } SINGLE PHASE EMERGENCY SENSING
 803
 804 } 3 PHASE NORMAL SENSING
 807
 806
 805 } NORMAL CONTROL POWER
 906
 905 } EMERGENCY CONTROL POWER



DRAWN	RA	10-20-03
CHECK	RA	12-05-03
APPD	M.K.	12-05-03

METRON
 A Division of
 Hubbell ICD, Inc.
 4301 Cheyenne Dr., Archdale, NC 27263

SCHEMATIC, THREE PHASE
 ZENITH TRANSFER SWITCH FOR
 ELECTRIC FIRE PUMP CONTROLLERS

OPTIONS:
CS33591C
SCALE SHEET

Metron Electric Fire Pump Controller Load Terminal Capacity

MP300, MP400, MP450, MP800

HP	Vts	Terminal Capacity
15-40	200	#8 - 250MCM
15-40	208	
15-50	240	
15-75	380-415	
15-100	480	

HP	Vts	Terminal Capacity
50	200	#6 - 3/0
50	208	
60	240	
100	380-415	
125	480	

HP	Vts	Terminal Capacity
60-75	200	#6 - 300MCM
60-75	208	
75-100	240	
125-200	380-415	
150-200	480	

HP	Vts	Terminal Capacity
100	200	#4 - 500MCM
100	208	
125	240	
250	380-415	
250	480	

HP	Vts	Terminal Capacity
125-150	200	(2) #2 - 600MCM
125-150	208	
150-200	240	
300	380-415	
300-400	480	

HP	Vts	Terminal Capacity
200-250	200	(3) #2 - 600MCM
200-250	208	
250-300	240	
350-400	380-415	
500-600	480	

MP420

HP	Vts	Terminal Capacity
15-60	200	#8 - 250MCM
15-75	208	
15-75	240	
15-125	380-415	
15-150	480	

HP	Vts	Terminal Capacity
75	200	#14 - 2/0
150	380	

HP	Vts	Terminal Capacity
100	200	#6 - 3/0
100	208	
100-125	240	
200	380-415	
200-250	480	

HP	Vts	Terminal Capacity
125-150	200	#6 - 300MCM
125-150	208	
150-200	240	
250-350	380-415	
300-400	480	

HP	Vts	Terminal Capacity
200-250	200	#4 - 500MCM
200-300	208	
250-300	240	
400-500	380-415	
500-600	480	

HP	Vts	Terminal Capacity
300	200	(2) #2 - 600MCM
600	380-415	
700	480	
700	380	

HP	Vts	Terminal Capacity
700	380	(3) #2 - 600MCM

MP430, MP435

HP	Vts	Terminal Capacity
15-60	200	#8 - 250MCM
15-75	208	
15-75	240	
15-125	380-415	
15-150	480	

HP	Vts	Terminal Capacity
75-100	200	#6 - 3/0
100	208	
100	240	
150	380-415	
200	480	

HP	Vts	Terminal Capacity
125-150	200	#6 - 300MCM
125-150	208	
125-200	240	
200-350	380-415	
250-400	480	

HP	Vts	Terminal Capacity
200-250	200	#4 - 500MCM
200-250	208	
250	240	
400	380-415	
500	480	

HP	Vts	Terminal Capacity
300	200	(2) #2 - 600MCM
300	208	
300	240	
500-600	380-415	
600-700	480	

MP700

HP	Vts	Terminal Capacity
15	240	#8 Max
15-25	380-415	
15-30	480	

HP	Vts	Terminal Capacity
15-50	200	#2/0 Max
15-50	208	
20-60	240	
30-100	380-415	
40-125	480	

HP	Vts	Terminal Capacity
60	200	#6 - 250MCM
60	208	
75	240	
150	480	

HP	Vts	Terminal Capacity
75-100	200	#4 - 500MCM
75-100	208	
100	240	
125-250	380-415	
200-250	480	

HP	Vts	Terminal Capacity
125	200	(2) #6-250MCM
125	208	

HP	Vts	Terminal Capacity
125	240	(2) #4-350MCM

HP	Vts	Terminal Capacity
150-200	200	(2) #2-600MCM
150-250	208	
150-300	240	
300-400	380-415	
300-600	480	