

Conversion Rings

Retrofit Mounting Options



Suitable for Kemlux III **Hazardous** or **Severe** Fixtures



HUBBELL
Industrial Lighting

www.hubbellindustrial.com



HUBBELL
Lighting

SEVERE
HAZARDOUS

CONVERSION RINGS RETROFIT MOUNTING OPTIONS

HUBBELL[®]
Industrial Lighting



The Conversion Rings' retrofit design converts competitor mounts to new LED fixtures. By specifying one of the five conversion rings below, Hubbell Industrial's KHL or KSL housing can be mounted on an existing field mount, substantially reducing field labor costs.

Features:

- Versatile
- Saves retrofit time
- Saves money
- Relight labor savings
- Maintains hazardous and severe location listings

EXISTING COMPETITOR'S MOUNT

WORKS WITH CROUSE HINDS, APPLETON AND HAZLUX

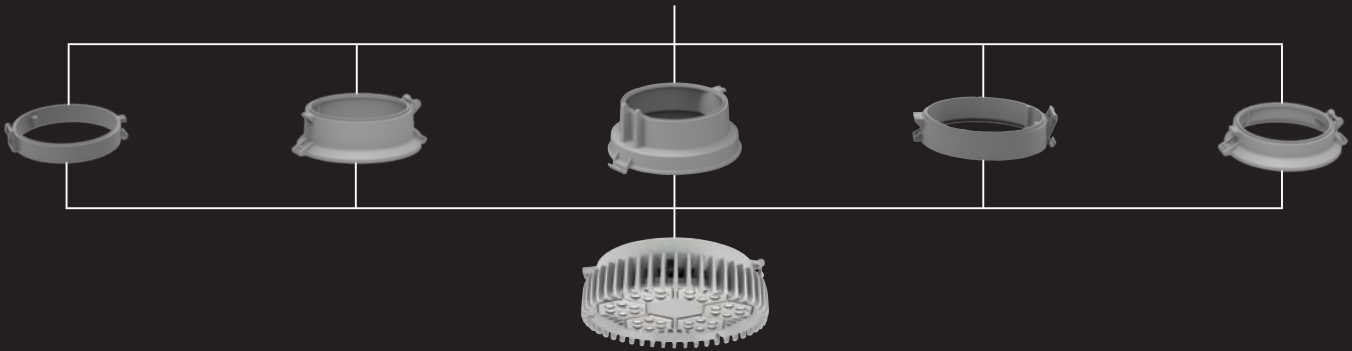

Fits Kemlux Mounting Style

Mounts to Incumbent Fixture

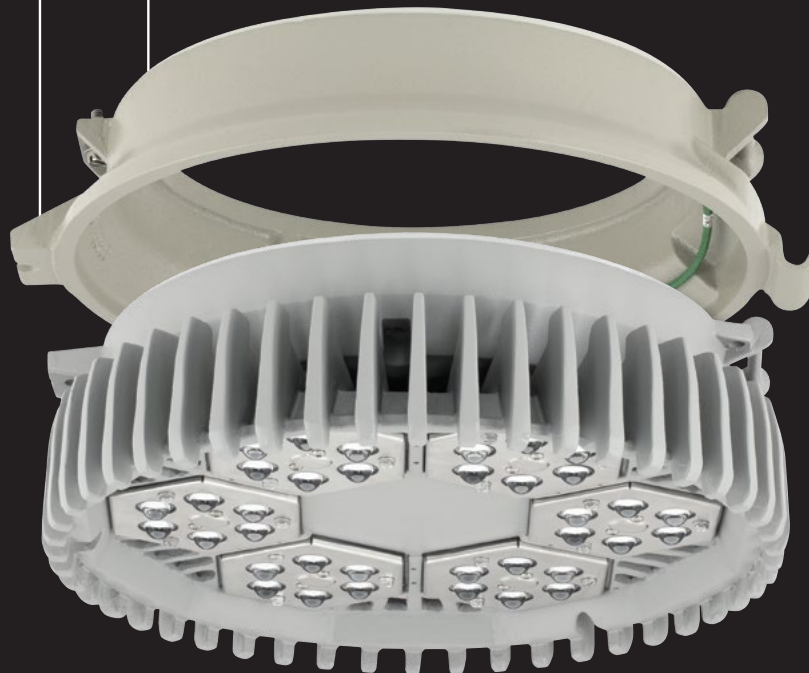

HUBBELL[®]
Lighting

Due to our continued efforts to improve our products, specifications are subject to change without notice. Copyright © Hubbell Lighting. All Rights Reserved.

For more information visit our web site: <http://www.hubbellindustrial.com/>
Phone: 1-864-678-1000