



PHB THE PERFORMANCE HIGH BAY



The best high bay for heavy industrial lighting

### FEATURES

- Up to 28,000 lumens
- Three lumen values (28,000, 20,000 and 14,000)
- Up to a full 65°C with no fold back
- Good side light and up light on the SPC and DLR optics
- Up to 141 Lumens per Watt
- IP66 Rated
- Tested to UL1598 Wet Location by CSA Laboratories
- DesignLights Consortium® (DLC) qualified - see website for specific QPL listings at [www.designlights.org](http://www.designlights.org)

### DIMENSIONS

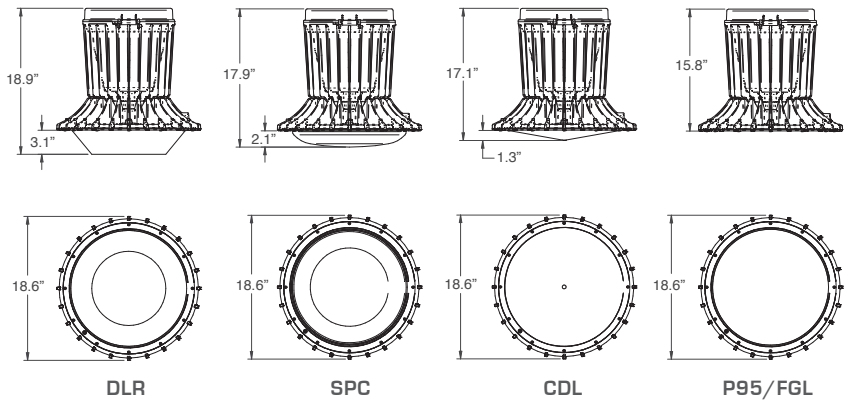

|     | LPW | SC   | MATERIAL           | SHAPE                   | FEATURE                                 |
|-----|-----|------|--------------------|-------------------------|---|
| P95 | 141 | 1.22 | Clear Acrylic      | Flat with a Slight Haze | Highest LPW                             |
| CDL | 134 | 1.11 | Clear Acrylic      | Conical Ribs            | Low Profile                             |
| DLR | 133 | 1.28 | Clear Acrylic      | Dropped Refractor       | Good Glare Control, Widest Distribution |
| 131 | 131 | 1.22 | Milk White Acrylic | Smooth Sag Lens         | Best Glare Control                      |

### MOUNTING OPTIONS



### LENS OPTIONS



**HUBBELL**  
**Lighting**

Due to our continued efforts to improve our products, specifications are subject to change without notice.  
 © 2018 Hubbell Lighting. All Rights Reserved.

For more information visit our web site: <http://www.hubbellindustrial.com/>  
 Phone: 1-864-678-1000