

DUAL PORT CHANNEL GENERATOR TYPE GSW1-AC

- ✂ **Intrinsically safe dual port SILBUS channel generator**
- ✂ **Intended for installation in safe areas**
- ✂ **Intrinsically safe SILBUS field bus networks can extend into hazardous areas**
- ✂ **Self-contained DIN rail mounted unit with a LCD screen**
- ✂ **Provides for 8, 16, 32, 64 or 128 channels at the two independent SILBUS network ports**
- ✂ **Four relay outputs**



DESCRIPTION

The GSW1 dual port channel generator is a self-contained DIN rail mounted unit that measures 225 mm (W) x 75mm (H) x 110mm (D). It provides for 8, 16, 32, 64, or 128 channels at the two independent SILBUS network ports. Each channel can be used for digital or analogue signals and each port provides signalling and power to field devices or transmitters that can allow network lengths of up to 10,000m of unshielded twisted pair cable.

Each channel of the GSW1 can be used to transfer a variety of protocols from the field to the channel generator and vice versa. The available data transfer can be digital or analogue values.

The channel generator has four general purpose relay outputs that can be configured as a single output relay (a multi-term OR, AND, NAND, SAND, NOR or FLIP FLOP output relay). The operation of these relay outputs can be configured via the front panel keypad and display or via the console port.

The GSW1 has two general purpose digital or contact type inputs. These can be assigned to any SILBUS channel.

TYPICAL APPLICATIONS

- SILBUS control and monitoring applications such as on conveyor and longwall installations.
- Interface between PLC and SILBUS via Modbus (RS-485)

CERTIFICATION

The Dual Port Channel Generator type GSW1-AC is IECEx certified under IECEx TSA 07.0002X. The GSW1-AC must be installed in the safe area. For installations in the hazardous area please refer to the GSW1-DC.

INTRINSICALLY SAFE INFORMATION

SILBUS	Uo = 10.5V	Ui = 12.6V
	Ci = 0uF	Li = 0uH
	Refer to certificate for further details	
POWER	Associated apparatus	
MODBUS PORT	Network Um below 250V	
RELAYS	Contacts Um below 250V	
INPUTS	Contacts Um below 250V	





SPECIFICATION

GENERAL

Terminations	Cage Clamp 4 mm ² (12 AWG)
Size	225(W)x75(H)x110(D)mm 8.9(W)x3.0(H)x4.3(D)inch
Mass	1.1kg (2.7lb)
Fixing	TS35 DIN rail
Ingress protection	IP20
Enclosure Material	Polycarbonate
Enclosure Colour	RAL 7032 Grey
Terminal Block Colour	Blue/Black
Operating Temperature	0°C - 40°C (32°F - 104°F)
Storage Temperature	-20°C - 80°C (68°F - 176°F)

POWER SUPPLY

Pin assignment	Pin 36: 24V AC power Pin 37: 24V AC power Pin 39: Mains Earth Pin 40: Mains Earth
Voltage	24V AC
Current	380mA

MODBUS

Modbus-RTU	2 wire RS485 port
Baudrate	9600, 19200, 38400
Parity	None1, Non2, Even and Odd
Pin Assignment	Pin 49: RS485 A+ Pin 50: RS485 B- Pin 51: Ground
Function Code	01, 02, 03, 04, 05, 06 & 16

SILBUS

Pin assignment	Pin 1: Signal Port 1 Pin 2: COM 1 Pin 34: Signal Port 2 Pin 35: COM 2
----------------	--

DIGITAL INPUT 1 and 2 TERMINATIONS

Pin 65	+24VF Contact supply
Pin 66	+ve Digital Input 1
Pin 67	-ve Digital Input 1
Pin 68	+ve Digital Input 2
Pin 69	-ve Digital Input 2
Pin 70	0V Contact wetting supply

RELAY OUTPUT

Relay 1

Pin 53	Relay changeover contact
Pin 54	Relay normally closed contact
Pin 55	Relay normally open contact

Relay 2

Pin 56	Relay changeover contact
Pin 57	Relay normally closed contact
Pin 58	Relay normally open contact

Relay 3

Pin 59	Relay changeover contact
Pin 60	Relay normally closed contact
Pin 61	Relay normally open contact

Relay 4

Pin 62	Relay changeover contact
Pin 63	Relay normally closed contact
Pin 64	Relay normally open contact

MEMORY MAPPING

The GSW1 Channel generator has a single MODBUS port that allows at PLC access to the channel generator database. This access can either be read or write, depending on the application. The PLC can read the status of digital signals (standard digital and safety digital) and the value of analogue signals (Analink, Fastlink and Datalink). When enabled, the PLC can also write to any digital signal within the database. This allows for control of field devices.

SILBUS I/O to Modbus-RTU Mapping

Address	R/W, FC	Function
3:0001 (A1) - 0008 (P8)	RO, FC04	I/O Map
1:0001(A1) - 0128(P8)	RO, FC02	I/O Map
0:0001(A1)-0128(P8)	RW, FC15	I/O Map
0:0001(A1) 0128(P8)	RW, FC15	I/O Map
0:0001(A1) 0128(P8)	RW, FC05	I/O Map

SILBUS Analogues to Modbus-RTU Mapping

Address	R/W, FC	Function
3:1001(A1) - 1004 (P7)	RO, FC04	Safety Status
1:1001(A1) - 1064(P7)	RO, FC02	Safety Status
3:2001(A1) - 2004(P8)	RO, FC04	Safety Quality
1:2001(A1) - 2064(P7)	RO, FC02	Safety Quality
3:3001(A1) - 3128(P8)	RO, FC04	Analink Value
3:3129(A1) - 3256(P8)	RO, FC04	Fastlink Value
3:4001(A1) - 4008(P8)	RO, FC04	Analink State
3:4009(A1) - 4016(P8)	RO, FC04	Fastlink State
3.5001	RO, FC04	SILBUS Status
1:4129(A1) - 4256(P8)	RO, FC02	Fastlink State





CONNECTION DIAGRAM

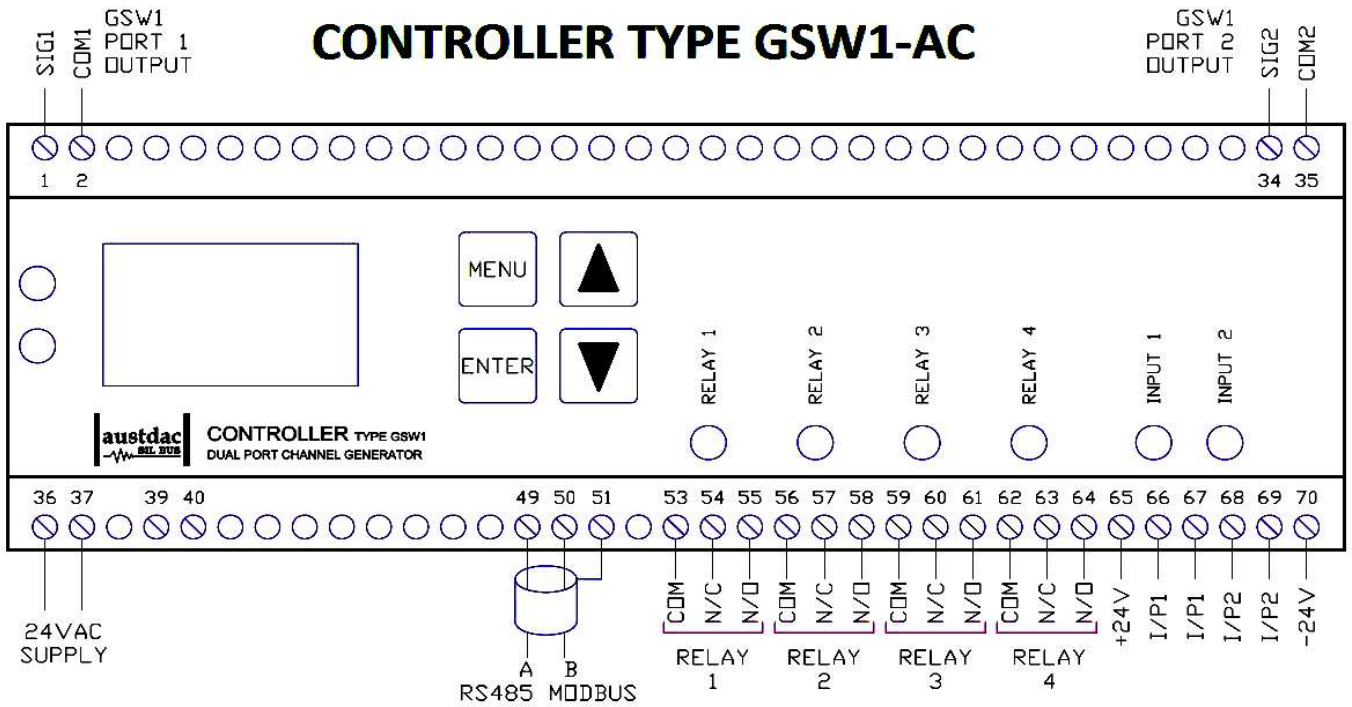

TYPICAL APPLICATIONS

One SILBUS network of the GSW1-AC can be used in the hazardous area while the other port can be used in the safe area, with unspecified equipment attached. If one network is used in the safe area, it can't be used in the hazardous area as well.

The two SILBUS networks of the GSW1-AC can be considered as separate intrinsically safe circuits, capable of voltage and current addition.

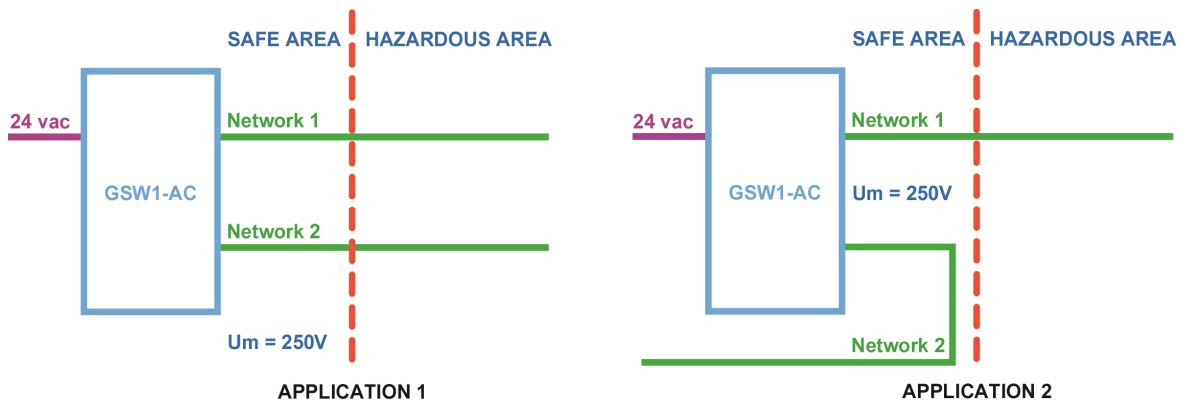



FRONT PANEL OPERATIONS

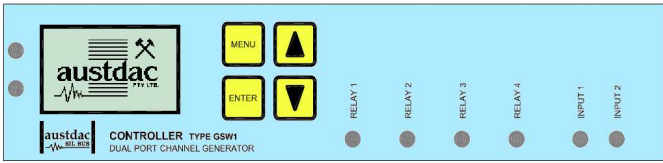

The front panel of the GSW1 is shown above. The two LEDs on the left side of the front panel provide a summary indication on the condition of the Channel Generator and MODBUS port activity.

The upper and lower LEDs provide SILBUS port status information, as shown in the tables below.

SILBUS Status LED (Upper LED)		
Colour	Flash rate	Meaning
Green	Flashing	SILBUS sync and main processor healthy
Orange	Flashing	SILBUS controller fault No sync
Red	Flashing	SILBUS port overloaded or "all channels on fault"
Red/Green or Amber	On or off	Fault

SILBUS Status LED (Lower LED)		
Colour	Flash rate	Meaning
Green	Flash once	MODBUS is receiving a packet
Red	Flash once	MODBUS packet/command error

A total of six I/O indicator LEDs are located in the lower right hand section of the GSW1 front panel. They consist of four 'RELAY' LEDs and two 'INPUT' LEDs.

The relay LEDs are illuminated to indicate that the associated relay is energised. In the same way, the 'INPUT' LEDs are illuminated to indicate that the associated input has been asserted.

MULTI-TERM LOGIC OPERATION

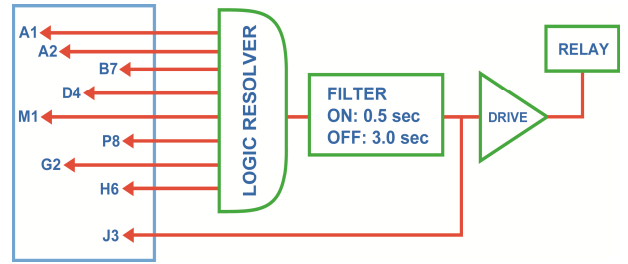

The GSW1-AC has six configurable multi-term logic gates, of which four drive the four general purpose relay outputs. These logic resolvers are typically used to implement conveyor 'OR' and 'AND' functions for emergency stop or remote isolation. The six basic logic functions are 'OR', 'AND', 'NAND', 'NOR', 'FLIP' and 'S-AND'.

By inverting the input terms, an 'S-NAND' is possible. 'S-AND' allows the two-bit safety channels to be used as a single term in the logic function.

Each logic resolver has a maximum number of input terms equal to the size of the common database of the channel generator i.e. 128, 64, 32, 16 or 8. The input terms can be specified in any order and do not need to be sequential. Channels assigned for analogue transmissions should not be used as input terms of the logic functions, otherwise results will be unpredictable.

The logic resolver's output is fed via a filter with independently variable on and off filter periods before being applied to the relay output. The on and off filter times can be independently configured from 100ms to hours in 100ms steps. These filter times are used to stop intermittent signals from causing inadvertent trips and alarms. The time filtering ensures that the output from the logic resolver must be on for the 'on' filter period before the relay output will be asserted. The filter off time ensures that the output from the logic resolver must be off for the 'off' filter period before the relay output will be negated.

DESCRIPTION	ORDER CODE
Dual Port Channel Generator Type GSW1-AC	SILBUS0165



AUSTDAC PTY LTD

HEAD OFFICE: CASTLE HILL AUSTRALIA
 MACKAY BRANCH QLD AUSTRALIA
 NORTH AMERICA BRANCH
 STAFFORDSHIRE UK BRANCH

+61 (0) 2 8851 5000
 +61 (0) 7 4955 2777
 +1 888 254 9155 (Toll Free in US and Canada)
 +44 (0) 1283 500 500

