

The 238 with external reflector



The 238 with wire guard

The 238 is a powerful and efficient wellglass that is designed for general purpose low and medium bay illumination. The luminaire has a side mounted increased safety terminal chamber eliminating the need for flameproof glands.

The wide ambient temperature range makes the 238 suitable for extreme environmental conditions.

## Standard Specification

## Features

Type of Protection	Ex d e (Flameproof, Increased Safety), Ex tD (Dust)
ATEX Classification	Group II Category 2 GD
Area Classification	Zone 1 and Zone 21 areas to EN 60079-10 -1 and EN 60079-10-2 with installation to EN 60079-14 and Gas Groups IIA and IIB
Certificate	EC Type Examination Certificate BAS08ATEX0177 IEC Ex BAS08.0056
Coding	Ⓔ II 2 GD Ex d e IIB Refer to table for T rating and Ambient
Enclosure	Aluminium alloy LM6 to BS 1490 (AC44100) All fastenings A4 stainless steel Toughened glass dome globe
Internal Reflector	High purity anodised aluminium
Entry	2 x M20 cable entries
Termination	3 core 6mm <sup>2</sup> max. conductor with looping
Installation	Flush mounting bracket
Windage	0.138m <sup>2</sup>
Control Gear	Internal copper/iron with PFC correction capacitor
Relamping	Access via front glass cover assembly
Burning Position	Universal
Ingress Protection	IP66 to EN 60529
Electrical Supply	220, 230, 240, 254V 50Hz - 70, 150 & 250W HPS/Metal Halide 220, 230, 240V 50Hz - 100W HPS

Installation to gas groups IIA and IIB

Ex e cable entries and looping  
as standard

Anchor chain on glass cover assembly

High ingress protection

External reflector (option)

Low temperature applications  
to -40°C

Compact construction

## International Approvals

ATEX, IECEx and EACEx

Std. Cat No.	Wattage	Lamp	Lampholder	TClass	T°C (Dust)	Ambient °C	Weight
238D/070/MS	70W	HPS and Metal Halide	E27	T4	125	-30 to +60*	17.0kg
238D/100/HS	100W	HPS	E40	T4	125	-40 to +60*	17.0kg
238D/150/MS	150W	HPS and Metal Halide	E40	T4	125	-40 to +40	18.0kg
238D/250/MS	250W	HPS and Metal Halide	E40	T3	150	-40 to +45*	20.0kg

Note: Refer to installation leaflet for cable rating on models marked \*  
The 250W luminaires have a 70°C cable rating at ambients of 30°C.

**Note: Please specify voltage at time of enquiry/order**

### Options – Suffix to Catalogue No.

/60	60Hz	/P	Marine grade polyester paint coating (RAL 7043)
/M25	M25 cable entries	/S	Stirrup mounting bracket
		/NC	No power factor correction capacitors fitted

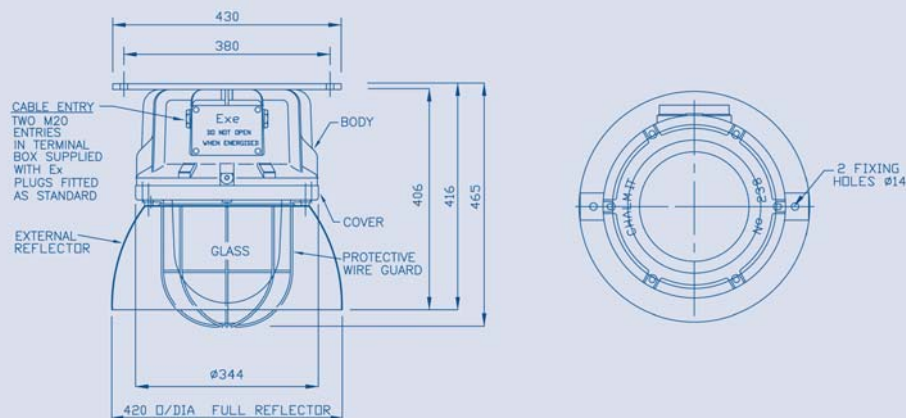

Accessories should be ordered separately

Catalogue Order Code

Pole mounting bracket assembly - stirrup mounting version only (42-64mm diameter poles)	S2400-0002
Wire guard	S2381-0012
External reflector	S2380-0001

Product design and specifications are subject to change without notice, please check the Chalmit website for latest specifications.

