



The 261 with external reflector



The 261 with wire guard

The 261 is an efficient high wattage wellglass for general task area and highbay lighting. The luminaire has a side mounted increased safety terminal chamber eliminating the need for flameproof glands.

The 261 is suitable for low temperature operation (-40°C) with high pressure sodium lamps.

Standard Specification

Features

| | |
|---------------------|---|
| Type of Protection | Ex d e (Flameproof, Increased Safety) |
| ATEX Classification | Group II Category 2 G |
| Area Classification | Zone 1 and Zone 2 areas to EN 60079-10-1 with installation to EN 60079-14 Gas Groups IIA and IIB |
| Certificate | EC Type Examination Certificate BAS01ATEX2309 |
| Coding | ⊕ II 2 G Ex d e IIB Refer to table for T rating and Ambient |
| Enclosure | Aluminium alloy LM6 to BS 1490 (AC44100) All fastenings A4 stainless steel Toughened glass dome globe |
| Reflector | High purity anodised aluminium |
| Entry | 2 x M20 cable entries |
| Termination | 3 core 6mm ² max. conductor with looping |
| Installation | Stirrup mounting bracket |
| Windage | 0.197m ² |
| Control Gear | Internal copper/iron with PFC correction capacitor |
| Relamping | Access via front glass cover assembly |
| Burning Position | Universal |
| Ingress Protection | IP66/67 to EN 60529 |
| Electrical Supply | 220, 230, 240, 254V 50Hz (HID) |

Installation to gas groups IIA and IIB

Ex e terminal chamber

Stainless steel fasteners

Anchor chain on glass cover assembly

Low temperature applications to -40°C

International Approvals

ATEX and GOST

IECEX Compliant

| Std. Cat No. | Wattage | Lamp | TClass | Ambient °C | Weight |
|--------------|---------|--------------|--------|------------|--------|
| 261D/150/HS | 150W | HPS | T4 | -40 to +50 | 31kg |
| 261D/250/HS | 250W | HPS | T4 | -40 to +50 | 32kg |
| 261D/400/HS | 400W | HPS | T4 | -40 to +50 | 33kg |
| 261D/250/MH | 250W | Metal Halide | T4 | -40 to +50 | 32kg |
| 261D/400/MH | 400W | Metal Halide | T4 | -40 to +50 | 33kg |

Note: Please specify voltage at time of enquiry/order

| Options – Suffix to Catalogue No. | | | |
|-----------------------------------|---|-----|---------------|
| /P | Marine grade polyester paint coating (RAL 7043) | /60 | 60Hz |
| /M25 | M25 cable entries | /TI | Timed ignitor |

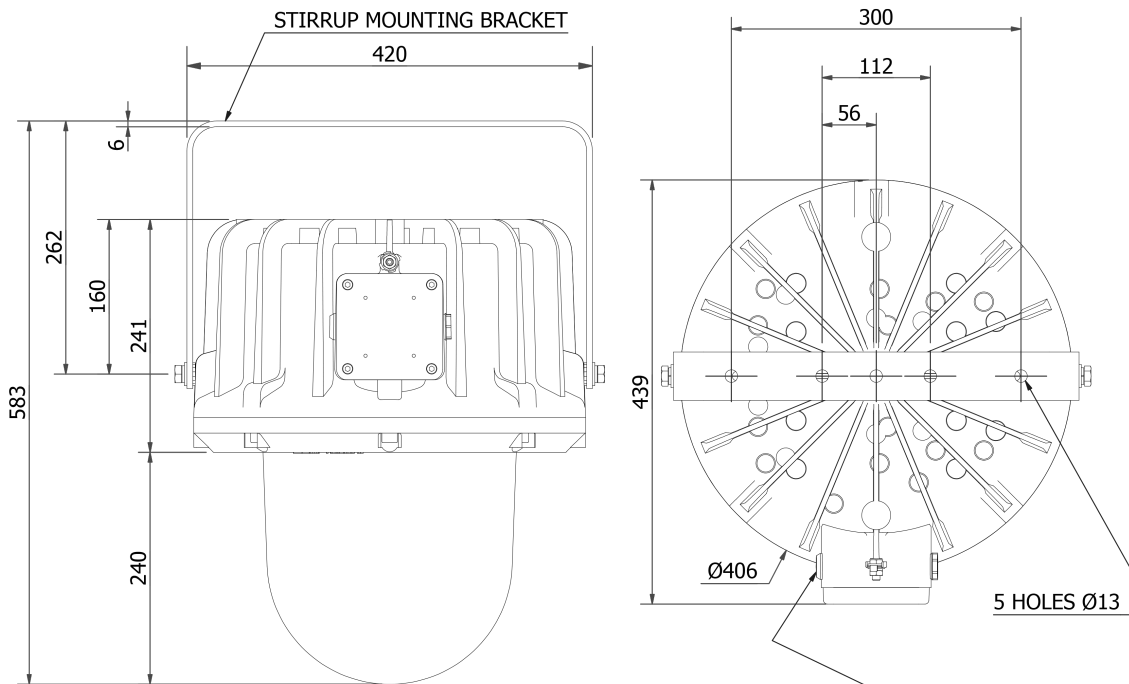

CABLE ENTRY - TWO M20 ENTRIES IN TERMINAL BOX SUPPLIED WITH ONE OFF Ex CERTIFIED BLANKING PLUGS & ONE OFF TRAVELLING PLUG AS STANDARD.

| Accessories Should be ordered separately | Catalogue Order Code |
|---|----------------------|
| Pole mounting bracket assembly (42-64mm diameter poles) | S2400-0002 |
| Wire guard | S2610-0003 |
| External reflector | S2610-0007 |

Product design and specifications are subject to change without notice, please check the Chalmit website for latest specifications.

