

Straight Blade Devices  
 15A, 125V, 2 Pole, 3 Wire Grounding  
 Elastogrip Connector Bodies



**Features**

- Thermoplastic elastomer housing
- Integral weatherproofing shroud seals connection between plug and connector
- Nylon compression nut keeps water and dust from getting into the body around the cord



**Ordering Information**

Description	Cord Diameter	UPC	Catalog Number
Yellow elastomer, watertight	.300"-.655" (7.6-16.6)	781786378186	<b>BRY15W47</b>

**Listings**

UL Listed to UL498 File E1706  
 CSA Certified to C22.2 No. 42 File 280C  
 NEMA® WD-6 Compliant

**Specifications**

Housing	Thermoplastic Elastomer
Contact Holder	Nylon
Terminal Retainer	Clear Polycarbonate
Contacts	.040" (1.0) Brass
Terminal Screws	#8-32 Brass , multiple drive
Terminal Clamp	Nickel plated steel
Assembly Screws	Plated steel

**Performance**

<b>Electrical</b>	
Current Interrupting	Certified for current interrupting at full rated current
Dielectric Voltage	Withstands 2,000V minimum
<b>Mechanical</b>	
Product Identification	Ratings are a permanent part of the device
Terminal Accommodation	#18-#12 AWG. Stranded copper wire only.
Terminal Identification	Terminals identified in accordance with UL 498 and CSA
<b>Environmental</b>	
Flammability	UL 94 HB or better
IP Suitability	IP55
Operating Temperatures	Maximum continuous 75°C; minimum -40°C (w/o impact)

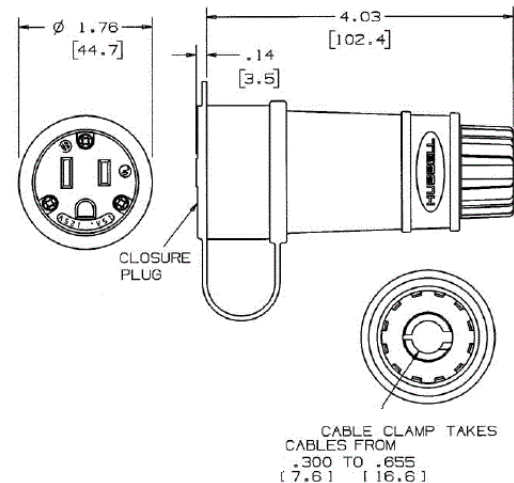

**Resources**

Customer Use Drawing  
 eCatalog