

# Raceway

## Metal Raceway

### HBL500 Series Transition Fitting

# BRYANT

#### Features

- For transitioning from either Wiremold® V500 to Hubbell HBL500 Raceway

#### Ordering Information

Description	Color	UPC Number	Catalog Number
Transition Fitting	Ivory	783585216676	HBL500TFIV



#### Listings

UL Listed  
CSA Certified

#### Specifications

Height	0.65"
Width	0.89"
Length	2.15"

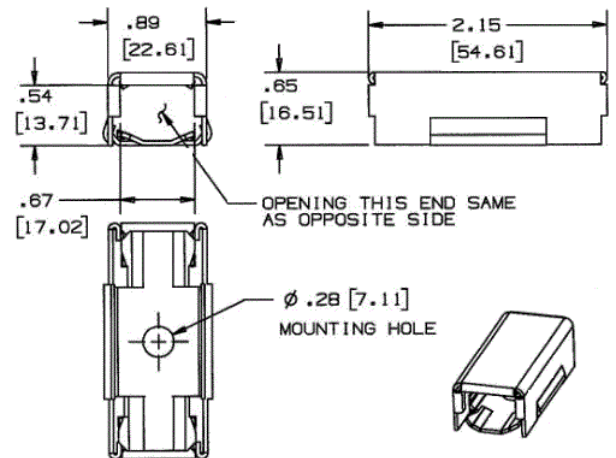

#### Online Resources

Customer Use Drawing  
eCatalog  
Installation Instructions

Dimensions in Inches (mm)

Bryant Electric • An affiliate of Hubbell Incorporated (Delaware) • 40 Waterview Drive • Shelton, CT 06484  
Phone (800) 323-2792 • Specifications subject to change without notice