

# Raceway

## Metal Raceway

### Flexible Sections

# BRYANT

#### Features

- For use with HBL500, HBL700 and HBL750 Series Raceway
- For getting around offsets, side bends, twisted turns or curved surfaces.

#### Ordering Information

Description	Color	UPC Number	Catalog Number
Flexible Sections	White	783585423029	HBL5700FWA



#### Listings

UL Listed  
CSA Certified

#### Specifications

Height	0.2"
Width	0.2"
Length	18.00"

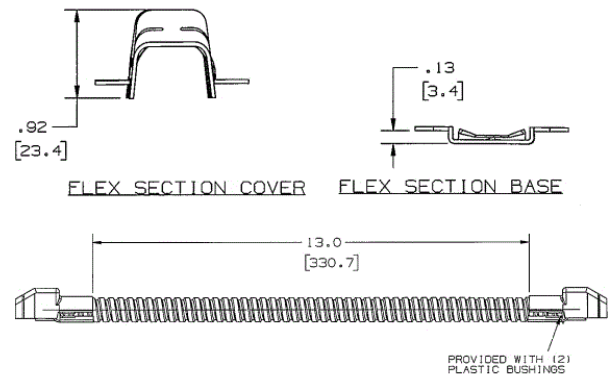

#### Online Resources

eCatalog

Dimensions in Inches (mm)

Bryant Electric • An affiliate of Hubbell Incorporated (Delaware) • 40 Waterview Drive • Shelton, CT 06484  
Phone (800) 323-2792 • Specifications subject to change without notice