

Raceway Metal Raceway Flexible Sections

BRYANT

Features

- For use with HBL500, HBL700 and HBL750 Series Raceway
- For getting around offsets, side bends, twisted turns or curved surfaces.



Ordering Information

| Description | Color | UPC Number | Catalog Number |
|-------------------|-------|--------------|----------------|
| Flexible Sections | White | 783585423036 | HBL5700FWA |

Listings

UL Listed
CSA Certified

Specifications

| | |
|--------|--------|
| Height | 0.2" |
| Width | 0.2" |
| Length | 18.00" |

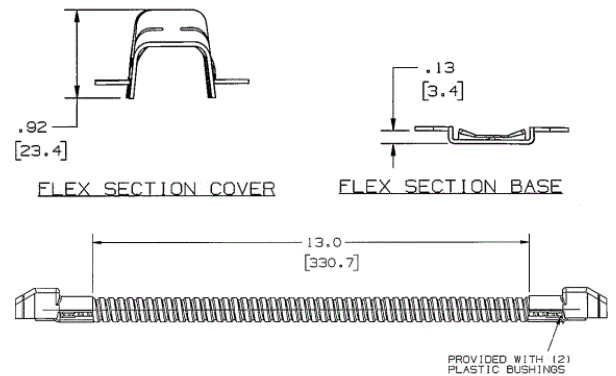

Online Resources

[Customer Use Drawing](#)
[eCatalog](#)
[Installation Instructions](#)

Dimensions in Inches (mm)

Bryant Electric • An affiliate of Hubbell Incorporated (Delaware) • 40 Waterview Drive • Shelton, CT 06484
Phone (800) 323-2792 • Specifications subject to change without notice