

Raceway Metal Raceway Grounding Clamp

BRYANT

Features

- For use with HBL500, HBL700 and HBL750 Series Raceway
- Provides grounding means for ½ in. trade size conduit using locknut.

Ordering Information

Description	Color	UPC Number	Catalog Number
Grounding Clamp	Steel	783585216799	HBL5709GC



Listings

UL Listed
CSA Certified

Specifications

Height	1.04"
Width	1.18"
Length	0.1"

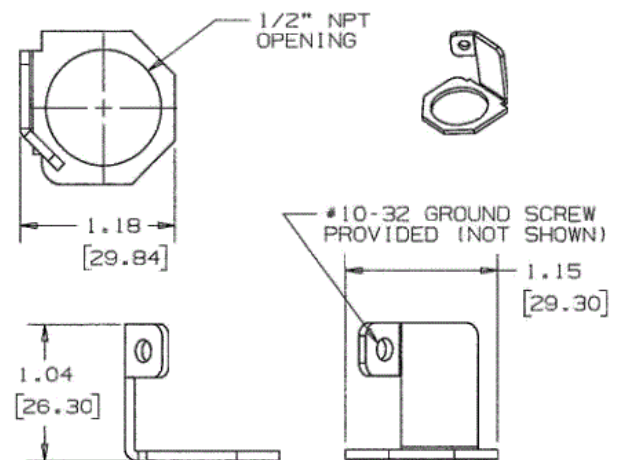

Online Resources

Customer Use Drawing
eCatalog
Installation Instructions

Dimensions in Inches (mm)

Bryant Electric • An affiliate of Hubbell Incorporated (Delaware) • 40 Waterview Drive • Shelton, CT 06484
Phone (800) 323-2792 • Specifications subject to change without notice