

# Raceway Metal Raceway Ground Clamp

# BRYANT

## Features

- For use with HBL500, HBL700 and HBL750 Series Raceway
- Used to provide additional grounding of raceway or to ground remotely located devices.
- Attach ground wire to screw as required by National Electrical Code.

## Ordering Information

Description	Color	UPC Number	Catalog Number
Ground Clamp	Steel	783585216782	HBL5709

## Listings

UL Listed  
CSA Certified

## Specifications

Height	2.00"
Width	0.5"
Length	0.1"

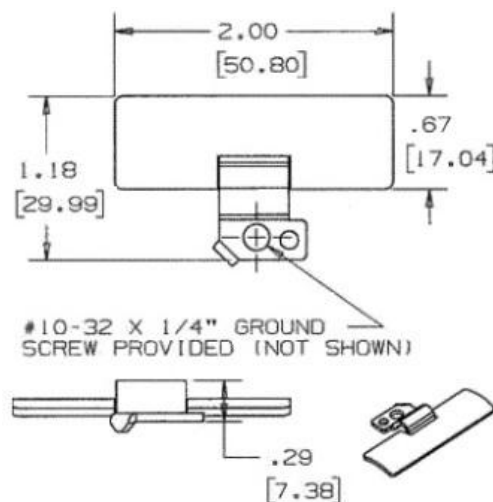

## Online Resources

Customer Use Drawing  
eCatalog  
Installation Instructions

Dimensions in Inches (mm)

Bryant Electric • An affiliate of Hubbell Incorporated (Delaware) • 40 Waterview Drive • Shelton, CT 06484  
Phone (800) 323-2792 • Specifications subject to change without notice