

Raceway
Metal Raceway
Specialty Round Boxes



Features

- Retrofit Box for Fire Alarm Detectors
- For use with HBL500, HBL700 and HBL750 Series Raceway
- For installing round alarm sensors.

Ordering Information

Description	Color	UPC Number	Catalog Number
Specialty Round Boxes	White	783585423326	HBL5739AABWA



Listings

UL Listed
 CSA Certified

Specifications

Height	6.50"
Width	6.50"
Length	1.62"

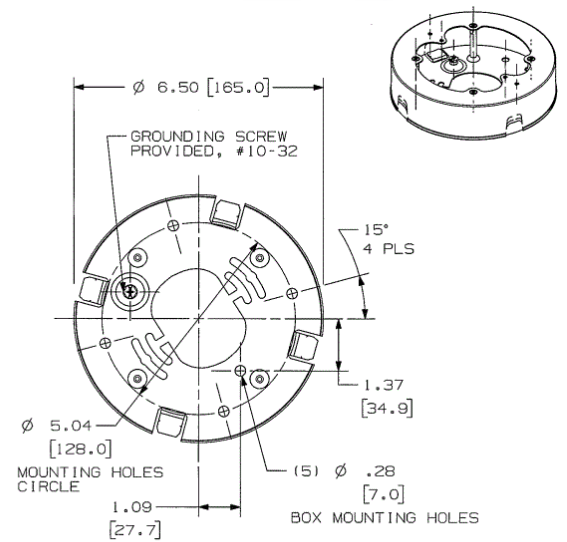

Online Resources

Customer Use Drawing
 eCatalog
 Installation Instructions

Dimensions in Inches (mm)

Bryant Electric • An affiliate of Hubbell Incorporated (Delaware) • 40 Waterview Drive • Shelton, CT 06484
 Phone (800) 323-2792 • Specifications subject to change without notice