

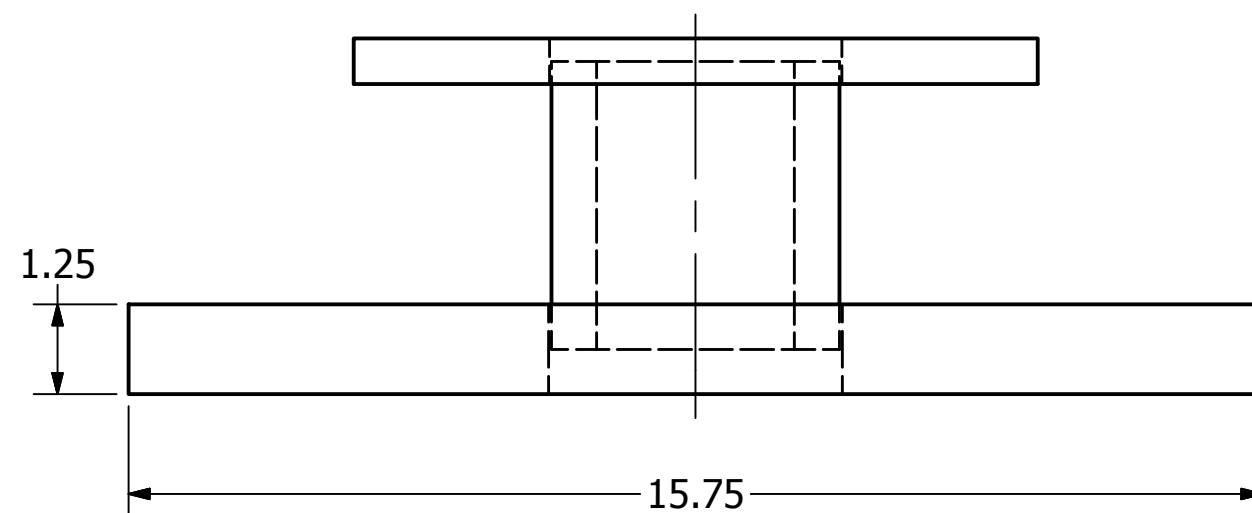

-NOTE-

1. (12) -- 5/8-11 HEX BOLT, HEX NUT, AND SPRING LOCKWASHER INCLUDED.
2. MAT'L: TUBE: 4.00 X 5/8 WALL.  
DRIVING PLATE: HOT ROLLED STEEL PER AISI M1020 OR ASTM A36.  
PLATE: AISI M1020 WITH ALTERNATE MATERIAL OF ASTM A36.

## CATALOG NUMBER C3030684

DESIGNED FOR TORQUE UP TO 20,000 FT. LBS.



<b>CHANCE</b> <sup>®</sup>	 <b>HUBBELL POWER SYSTEMS, INC.</b>			
	TITLE <b>UNIVERSAL DRIVING TOOL</b>			
<small>CONFIDENTIAL: THIS DRAWING AND ITS CONTENTS ARE CONFIDENTIAL AND THE EXCLUSIVE PROPERTY OF HUBBELL POWER SYSTEMS. NO PUBLICATION, DISTRIBUTION, OR COPIES MAY BE MADE WITHOUT THE WRITTEN CONSENT OF HUBBELL POWER SYSTEMS. HUBBELL POWER SYSTEMS UNPUBLISHED ALL RIGHTS RESERVED UNDER THE COPYRIGHT LAWS.</small>	SIZE <b>B</b>	CAT / PART / ASSY NO. <b>C3030684</b>	DWG NO. <b>SA3030684</b>	REV <b>A</b>
	<small>DO NOT SCALE THIS DRAWING</small>	DRN BY JMT	DATE 3/13/19	SHEET 1 OF 1