



Thomas Research Products

SSL Solutions Faster Than The Speed Of Light™

ESTS Energy Saving Toggle Switch Patent Pending

The ESTS Energy Saving Toggle Switch is a simple, Universal Voltage (120-277V) Bi-Level lighting control that can be installed in a Fluorescent or LED light fixture, controlling two ballasts or drivers through simple “toggling” of a standard wall switch

Features

- ◆ Input Voltage - Universal 120-277 Volts
- ◆ For use in ambient temperatures 60°F or higher
- ◆ Output Load - 2.1 Amps @ 120V (250W Max)
0.9 Amps @ 277V (250W Max)
- ◆ Typical Switched Circuits
 - ◆ 2,3 or 4 lamp Universal Voltage T-8 Ballasts
 - ◆ 2,3 or 4 lamp Universal Voltage T-5 Ballasts
 - ◆ LED Loads up to 250W
- ◆ Power on - Device boots up in Low Light Level
- ◆ Toggle Wall Switch Off/On - High Light Level
- ◆ 5 Year Warranty, 90°C Maximum Case Temperature
- ◆ Integrated mounting tabs allow easy retrofit into existing fixtures using two sheet metal screws
- ◆ Examples of Energy Savings:

Fixture	Primary Ballast	Switched ballast	Energy Savings
4 Lamp Fluorescent	2 Lamp	2 Lamp	50%
6 Lamp Fluorescent	4 Lamp	2 Lamp	33%
6 Lamp Fluorescent	2 Lamp	4 Lamp	66%
8 Lamp Fluorescent	4 lamp	4 Lamp	50%

Wiring Examples

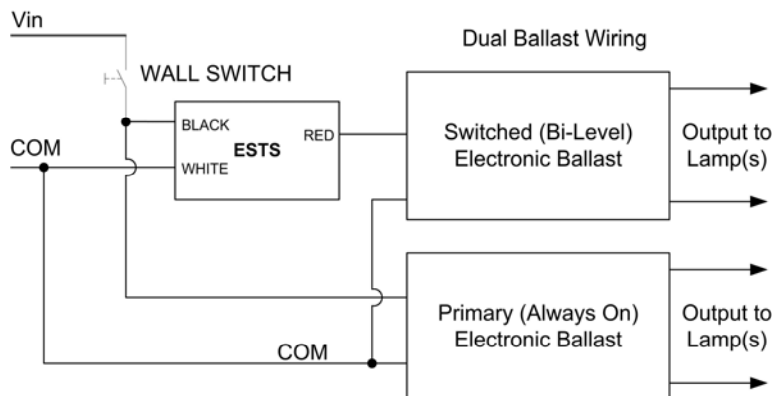

Dimensions

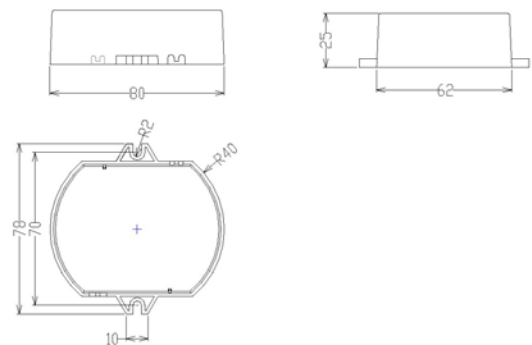

If used with fluorescent ballasts, the ESTS is recommended for switching programmed start ballasts only. It will work with Instant Start ballasts but switching instant start ballasts may lead to premature lamp failures. See ballast and lamp manufacturers recommendations for switching applications.

10-10-12