

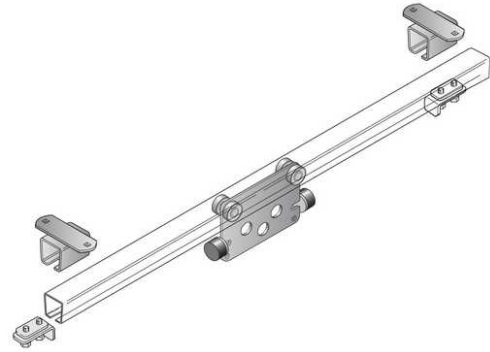

W6F-000006 Tool Rail Kit 6', 250 Lb. Capacity

By Gleason Reel
Catalog # [W6F-000006](#)

250 lb. Capacity Tool Rail Kits includes (1) galvanized steel rail (length per model), (1) heavy duty tool trolley, (2) hanger brackets, and (2) end stops.



Features

- Designed for large air tool balancers
- Can be mounted on benches, booms, or ceilings
- Maximum 250 lb.(113kg) safe load rating

General

Load Capacity	250 lbs
Series	WS60 - C-Rail
Type	Rail Kit
UPC	783246010964

Product Assets

- [Brochures - ToolAssistPro Idea Book](#)
- [Brochures - GLEASON_SpecApps_BROCHURE](#)
- [Catalogs - Tool Assist Pro Ergonomic and Material Handling Products](#)
- [Product Logo - ToolAssistPro-Logo](#)
- [Video - Tool Assist Pro for material handling and ergonomics](#)



A proud member of the Hubbell Family.

©2024 Hubbell Incorporated. All rights reserved.
GRD-W6F-000006-SPEC-EN | REV 1/2024