



HDN106N

LED Floodlight

The **HDN106N** is an outstanding luminaire, with a variety of beam options to suit any industrial application.

Up to four modules can be interlinked to increase the output without impacting on the product performance, and provide an effective replacement for conventional HID floodlights, up to 250W.



CE

International Approvals

Mounting Options

Floodlight. Pendant. Bulkhead. High Bay. Pole/Column. Road Lighting.

Standard Specification

HDN106N LED Floodlight

Ambient °C	-20 to +55
Enclosure	LM6 Aluminium with epoxy powder finish (RAL 7035) and Polycarbonate diffuser
Entry	2 x M20 cable entries
Termination	3 core 4mm ² max. conductor with looping
Installation	Stirrup mounting bracket
Control Gear	Electronic Driver
Colour Temperature (CCT)	Refer to Ordering Matrix
Colour Rendering Index (Ra)	>70
Maintenance	M8 Hex Head and M6 SKT Head
Ingress Protection	IP66/67 to EN 60529
Surge Protection	4kV line to line, 6kV line to earth
Electrical Supply	Refer to Ordering Matrix

Features

- ◆ Highly **Energy Efficient**
- ◆ **Instant on** crisp white light output
- ◆ **Modular design** allowing up to four interlinked luminaires, each providing a delivered output > 5500lm
- ◆ **Lower power consumption** than HID lamps
- ◆ **Lightweight** (6kg per module) lighting solution
- ◆ **>150,000 maintenance free hours** at 25°C (L70)

HDN106N						
Version*	Voltage	Beam Pattern**	Mount	Light (CCT)	Cable Entries	Other Options
<ul style="list-style-type: none"> 0 – 24 LEDs [26W] 1 – 48 LEDs [43W] 2 – 96 LEDs [87W] 3 – 144 LEDs [129W] 4 – 192 LEDs [174W] 	<ul style="list-style-type: none"> H – 100-254V AC L – 18-54V AC/DC 	<ul style="list-style-type: none"> N – Narrow (6565lm) M – Medium (5882lm) W – Wide (5624lm) X – Extra Wide (5547lm) 	<ul style="list-style-type: none"> H – Horizontal Mount [single unit] V – Vertical Mount [multiple units] C – Ceiling Mount 	<ul style="list-style-type: none"> W – Cool White (5000K) X – Warm White (3000K) 	<ul style="list-style-type: none"> 0 – M20 5 – M25 	<ul style="list-style-type: none"> 04 – RAL 7035 (Grey) FG – Glass front cover

*Power consumption provided in square brackets

**Delivered outputs based on single module 48LED version

Typical ordering reference: **HDN106N1HWHW004**

Single unit (24/48 LEDs)

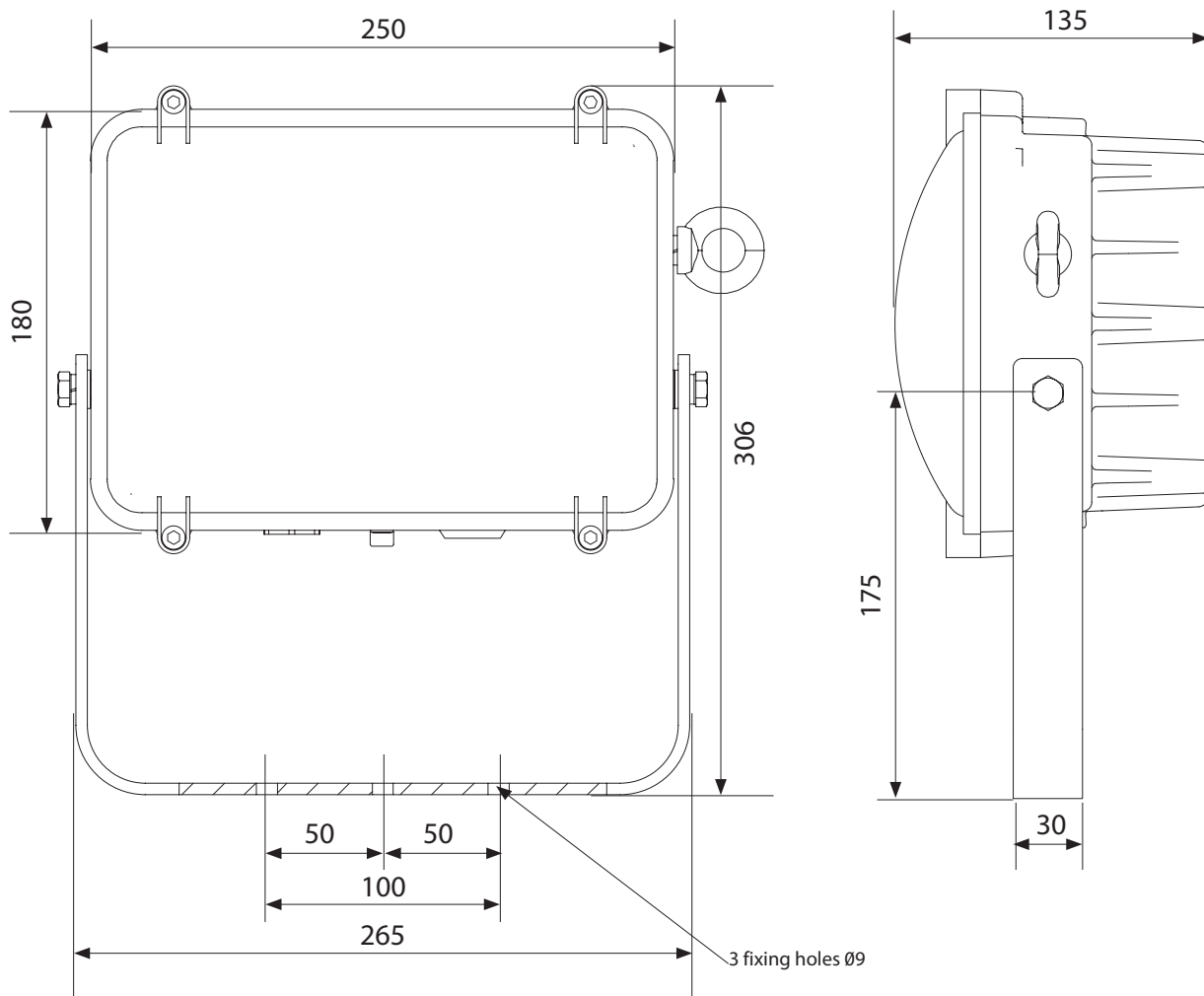

Double unit (96 LEDs)

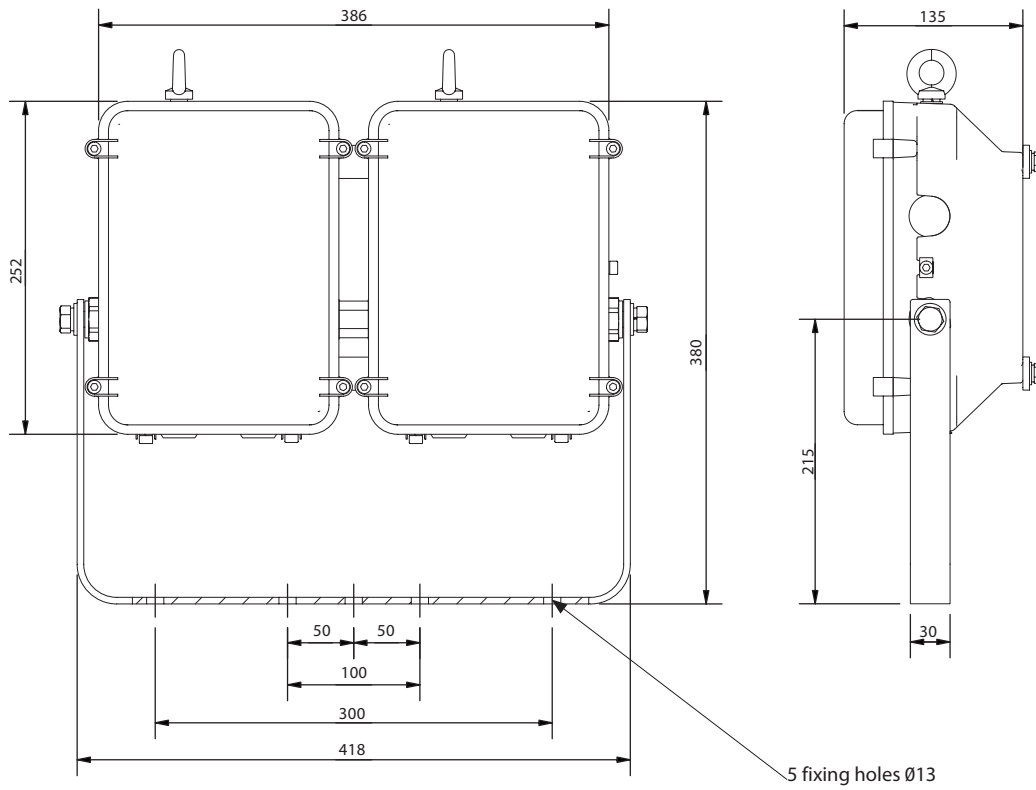

Triple unit (144 LEDs)

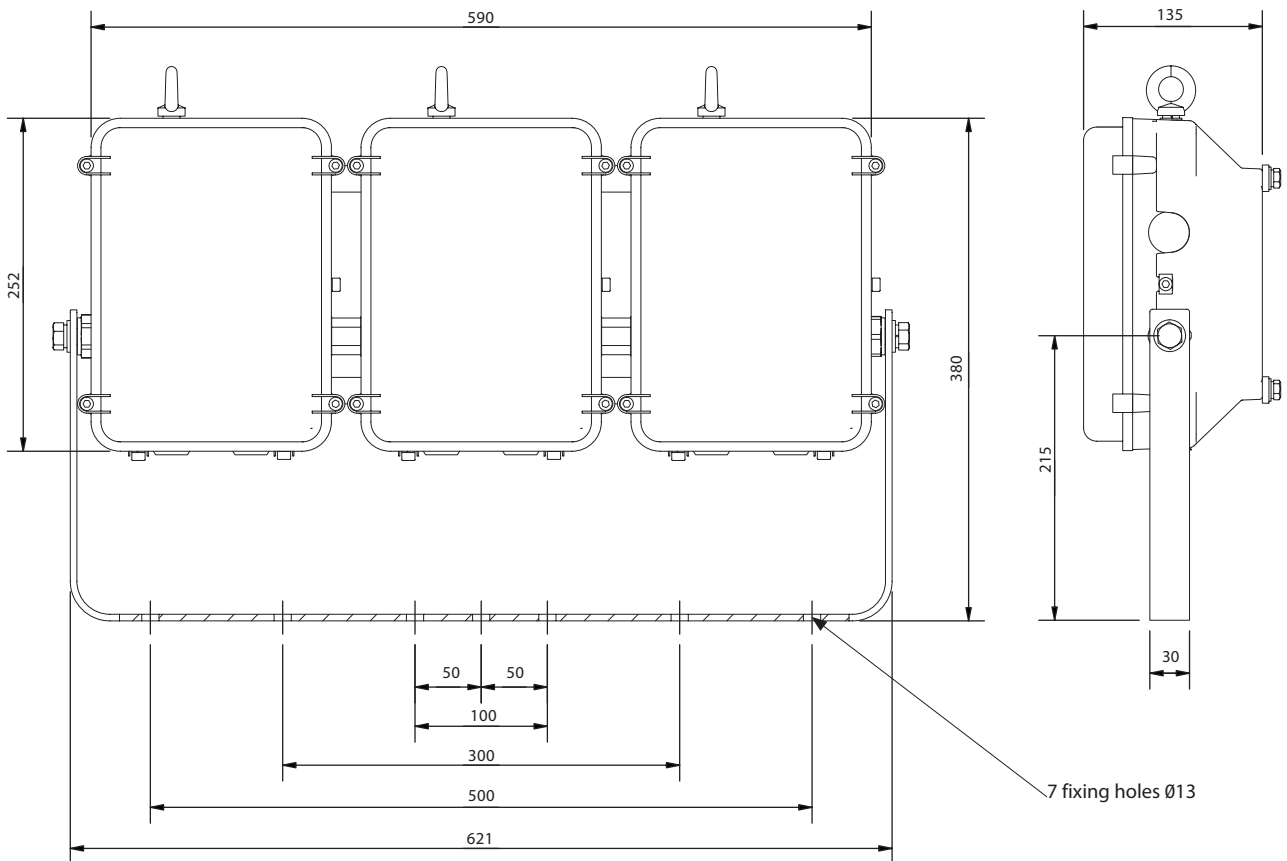

Quadruple unit (192 LEDs)

