

---

# Belt Rip Switch

## Type BRS1



### Description

The Austdac BRS1 Belt Rip Switch provides crucial safety for conveyor systems. When belt tears or foreign objects protruding through the belt are detected, it can shut down the conveyor operation.

The rip switch acts as an early warning system. Position it strategically near transfer points along the conveyor. Add it at regular intervals on longer systems. The BRS1 ensures smooth and safe conveyor system operations, minimizing downtime and reducing maintenance costs.

### Features

- Volt-free contacts connect to any digital control system
- Mounting for Austdac SILBUS or HubBus transmitters
- Includes two 20mm gland entries for cable access
- Screw terminal connections
- Constructed of UV-resistant, antistatic polycarbonate, UL94 HB flammability rated
- Wide operating temperature range, -40°C to +60°C
- IP66

### Certifications

- UL Listed (pending)
- CSA Listed (pending)
- As an Ex i simple apparatus, IECEx and ATEX certification is not required

# BRS1 Belt Rip Switch

## Specifications

General	
<b>Name</b>	Belt Rip Switch, Type BRS1
<b>Type</b>	BRS1
<b>Operating temperature</b> <i>Note: Equipment placed inside may reduce overall system operating temperature range</i>	-40°C to +60°C -58°F to +140°F
<b>Storage temperature</b>	-50°C to +80°C -58°F to +176°F
<b>Operating relative humidity range</b>	10% to 90% non-condensing
<b>Size H x W x D</b> <i>(Not including Magnet Mechanism)</i>	252 x 105 x 124 mm 9.8 x 4.1 x 4.7 inches
<b>Ingress protection</b>	IP66
<b>Electrical connections</b>	Screw terminals
<b>Maximum conductor size</b>	2.5 mm <sup>2</sup> .09 inches <sup>2</sup>
<b>Housing material</b>	Polycarbonate UL94 HB
<b>Housing colour</b>	Safety yellow
<b>Actuator type</b>	Magnet Switch
<b>Fixing fasteners</b>	2 x M8 or M10 bolts
<b>Fixing centres</b>	230 mm 9.05 inches
<b>Fixing slots</b>	20 x 11 mm 0.78 x 0.43 inches
<b>Gland / cable entries</b>	Two down facing
<b>Gland size</b>	20 mm
<b>Mass</b>	0.95 kg 2.1 pounds

Switch Contacts	
<b>Input Type</b>	SPDT
<b>Number of Switches</b>	1
<b>Voltage Max</b>	175 VDC 120 VAC
<b>Current Max</b>	250 mA DC 180 mA AC

## Ordering Details

Description	Order Code
<b>Belt Rip Switch - Type BRS1</b> , comes with 5m wire rope, 2 x standoffs, 1 x tension adjustment	SW0065M

## Dimensions

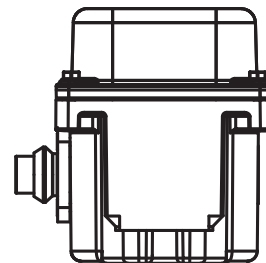
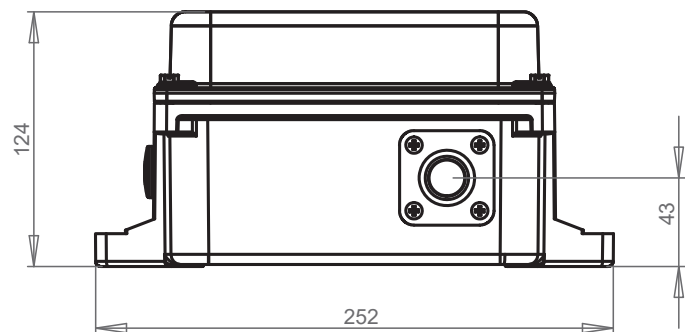
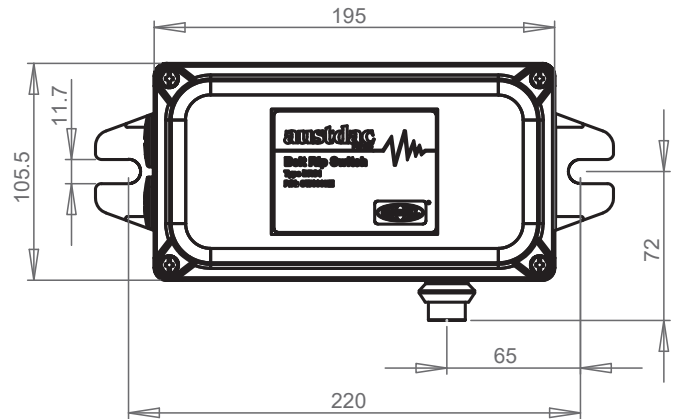

A proud member of the Hubbell family.

©2023 Hubbell Incorporated. All rights reserved.  
Hubbell and the Hubbell logo are registered trademarks or trademarks of Hubbell Incorporated. All other trademarks are the property of their respective owners.  
Head Office / Australia Wide | +1 800 568 984  
International / Pittsburgh | +1 888 254 9155  
[www.hubbell.com/austdac](http://www.hubbell.com/austdac)

HHI-AUS-SF-UK-00972 06/2023